

330 \ P

Skid Steer



JOHN DEERE





330 P-TIER SKID STEER

BUILT WITH YOUR OPERATION IN MIND

For over 50 years, we've relied on you — the owners and operators who run them — to tell us what makes our skid steers work on real jobsites. Inspired by everything we learned, we've reimagined our large-frame 330 P-Tier in some productive new ways. We put more horsepower under the hood and redefined cab comfort. Then we maximized lift height, dump clearance and reach, bucket breakout force, and machine stability. And added options like integrated machine technology, high-flow auxiliary hydraulics to optimize attachments, and your choice of control styles and performance features. All to enhance the operator experience and provide more possibilities for the work you can do.

FEATURES

Packed for productivity

Impressive power increase to 98 gross horsepower packed into a proven compact frame helps the 330 P-Tier Skid Steer effortlessly push through the most demanding tasks. Plus it can capably maneuver around a wide range of jobsites and also transports easily.

All about the operator

Next-generation cab filled with ergonomic creature comforts like a premium heated/ventilated seat, low-effort joystick controllers with adjustable performance modes, 25-button sealed-switch module to streamline settings, and deluxe LCD monitor puts operators of all skill levels at ease. Larger glass area increases visibility for the operator. Sealed and pressurized to minimize dust and noise, the cab is also isolated from the frame for a smooth ride.

Take control your way

Electrohydraulic (EH) ISO-pattern joystick controls that allow customized machine operations based on operator preference come standard. EH four-way controls, including EH foot control, ISO joystick control, H-pattern joystick control, and ISO and foot controls, are optional.

Repeat performance

Shorten cycle times and speed production in repetitive boom applications with the optional EH boom performance package that automates functions.

Flex your attachment muscle

Equip your 330 P-Tier with your choice of over 100 available John Deere attachments to boost the versatility of your fleet. Expanded mulching head and cold planer models can help open up new work opportunities.



**POWER BOOST
TO 98 HP PUSHES
PRODUCTIVITY**

Load warrior

Height to hinge pin of 11 feet enables the 330 P-Tier to easily load tandem-axle dump trucks, fill hoppers, and feed mixers. Additional reach to truck-bed height comes in handy for moving pallets of pavers or other weighty materials.

Get in the speed zone

Standard two-speed transmission delivers travel speeds of over 12 miles per hour, for rapid work cycles that push productivity even further.

Improve your grades

Optional Onboard Grade Indicate provides a real-time readout of cross-slope (machine roll) and mainfall slope (machine pitch) on the in-cab monitor. Reference absolute value, or machine relationship to an absolute flat plane, to easily grade a flat pad. Access relative value, or machine relationship to the existing grade, to steepen that grade.

In a whole new light

Opt for a new 8-inch touch-screen display to clearly access and monitor vital machine data. Optional LED side lighting, rearview camera, and Surround View further enhance jobsite visibility.

Run long

Increased tank capacity for both fuel and diesel exhaust fluid (DEF) lets you run all day without having to refill. Tilt the hood up for simple ground-level access to the dipstick, filters, and fuel and fluid fills. Convenient cab-footwell access helps speed cleaning.



330 P-TIER SKID STEER



**OPTIONAL ONBOARD
GRADE INDICATE
EASES GRADING ON
SLOPES & FLAT PADS**



Safety features

Standard personal-protection features include in-cab-activated boom lock and triple-interlock system that detects the presence of the operator.

Connected machines

John Deere construction equipment comes with in-base connectivity — free from subscriptions or annual renewals. Analyze critical machine data, track utilization, review diagnostic alerts, and more from **the John Deere Operations Center™**. The Operations Center also enables **John Deere Connected Support™**, which uses data from thousands of connected machines to proactively address issues before they arise. With your approval, your dealer can also remotely monitor machine health, diagnose problems, and even update machine software without a trip to the jobsite.*

*Availability varies by region and product. Options not available in every country.

While general information, pictures, and descriptions are provided, some illustrations and text may include product options and accessories NOT AVAILABLE in all regions, and in some countries products and accessories may require modifications or additions to ensure compliance with the local regulations of those countries.

Engine		330 P-TIER	
Manufacturer and Model	Yanmar 4TNV94FHT	Displacement	3.1 L (186.3 cu. in.)
Non-Road Emission Standard	EPA Final Tier 4 (FT4)/EU Stage IV	Rated Engine Speed	2,500 rpm
Cylinders	4	Torque Rise	47% at 1,700 rpm
Gross Rated Power (ISO 14396)	73.0 kW (98 hp) at 2,500 rpm	Aspiration	Turbocharged, intercooled
Net Peak Power (SAE J1349 / ISO 9249)	70.8 kW (95 hp) at 2,500 rpm	Air Cleaner	Dry dual element
Peak Torque	382 Nm (281.8 ft.-lb.) at 1,700 rpm		
Cooling			
Fan Type	Variable-speed hydraulic drive standard / reversing fan drive optional		
Powertrain			
Type	Electrohydraulic (EH); 4 – 100 heavy-duty (HD) continuous-loop chain		
Travel Speeds			
Low	12.07 km/h (7.5 mph)		
High	20.10 km/h (12.5 mph)		
System High-Pressure Relief	34 474 kPa (5,000 psi)		
Axles		Induction-hardened, 1-piece forged axle shafts with maintenance-free oil-bath lubrication of inner and outer axle bearings	
Maximum Axle Torque	8480 Nm (6,235 lb.-ft.)		
Tractive Effort	3905 kgf (8,610 lbf)		
Final Drive		High-strength, adjustment-free chains	
Brakes		Integral, automatic, spring-applied, hydraulically released, wet-disc park brake	
Hydraulics			
Pump Flow		Hydraulic Horsepower Flow (calculated)	
Standard	94.6 L/m (25 gpm)	Standard	37.5 kW (50.3 hp)
Total With High-Flow Option	147.6 L/m (39 gpm)	High	58.5 kW (78.5 hp)
System Pressure at Couplers	23 787 kPa (3,450 psi)	Auxiliary Hydraulics	Connect-under-pressure with 1/2-in. flat-faced couplers
Cylinders			
Type	John Deere heat-treated, chrome-plated, polished cylinder rods, hardened steel (replaceable bushings) pivot pins		
Electrical			
Voltage	12 volt		
Battery Capacity	950 CCA		
Alternator Rating	120 amp		
Lights		Halogen: 2 front and 1 rear standard / deluxe LED: 4 front and 1 rear optional	
Operator's Station			
ROPS (ISO 3471) / FOPS (ISO 3449) structure with quick-pivot standard			
Tires/Wheels			
Standard Tire Size	14 x 17.5 14 PR Titan HD2000-II		
Serviceability			
Refill Capacity			
Fuel Tank	96.5 L (25.5 gal.)		
Operating Weights			
Base Machine	4508 kg (9,930 lb.)		
Machine Dimensions			
A Length Without Bucket	3.17 m (125.0 in.) (10 ft. 5 in.)		
B Length With Construction Bucket	4.01 m (158 in.) (13 ft. 2 in.)		
C Width Without Bucket	1.99 m (78.5 in.) (6 ft. 7 in.)		
D Height to Top of ROPS	2.19 m (86.3 in.) (7 ft. 2 in.)		
E Height to Hinge Pin	3.36 m (132.0 in.) (11 ft. 0 in.)		
F Dump Height With Construction Bucket	2.50 m (98.6 in.) (8 ft. 3 in.)		
G Dump Reach With Construction Bucket (no edge)	0.90 m (35.6 in.) (3 ft. 0 in.)		
H Wheelbase	1.27 m (49.9 in.) (4 ft. 2 in.)		
I Ground Clearance With 14 x 17.5 Tire	0.25 m (9.7 in.)		
J Angle of Departure	23 deg.		
K Front Turn Radius With Foundry Bucket	2.14 m (84.3 in.) (7 ft. 0 in.)		
L Dump Angle (full lift height)	48 deg.		
M Bucket Rollback (ground level)	35 deg.		

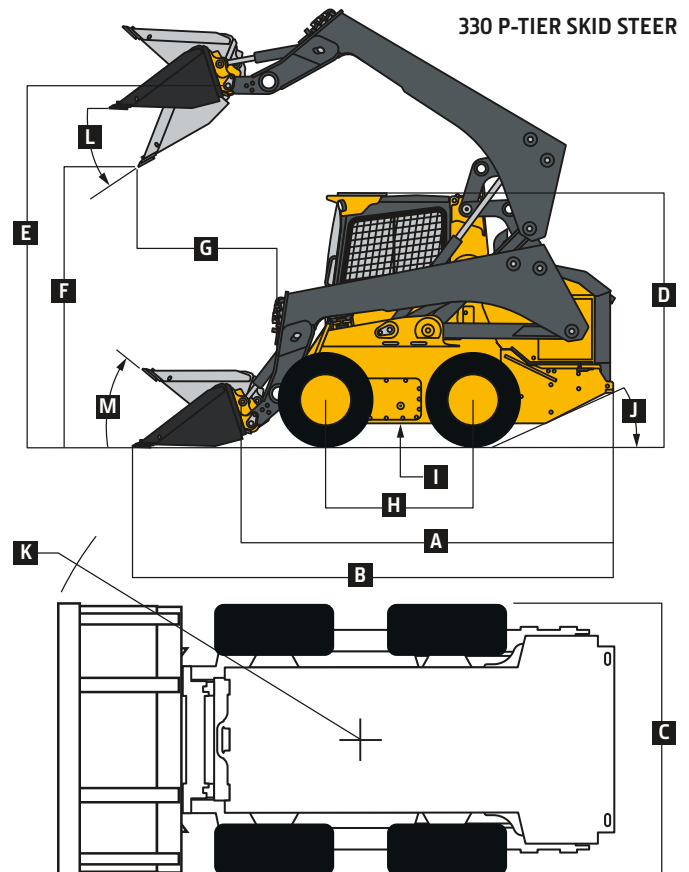

While general information, pictures, and descriptions are provided, some illustrations and text may include product options and accessories NOT AVAILABLE in all regions, and in some countries products and accessories may require modifications or additions to ensure compliance with the local regulations of those countries.

Loader Performance		330 P-TIER	
Bucket Type			
Tipping Load With Construction Bucket	2679 kg (5,900 lb.)		
SAE Rated Operating Capacity With Construction Bucket	1339 kg (2,950 lb.)		
Breakout Force	<i>With Foundry Bucket</i>	<i>With Construction Bucket</i>	
Boom	2996 kg (6,600 lb.)	2724 kg (6,000 lb.)	
Bucket	4767 kg (10,500 lb.)	3360 kg (7,400 lb.)	

Additional equipment

Key: ● Standard ▲ Optional or special
See your John Deere dealer for further information.

330 P Engine

- Meets EPA Final Tier 4/EU Stage IV emissions
- Yanmar 4TNV94FHT
- Auto-idle
- Automatic fan tensioner
- Automatic preheat
- Electronic injection system
- ▲ Engine air precleaner kit
- Fuel tank, 96.5 L (25.5 gal.)
- John Deere COOL-GARD™ II Extended-Life Engine Coolant
- John Deere Plus-50™ 10w30 initial engine oil fill[§]
- 4-cylinder, 73.0 kW (98 gross hp)/70.8 kW (95 net hp), 3.1-L (186.3 cu. in.) displacement
- 5-micron primary fuel filter and water separator
- ▲ Cold-weather starting package

Cooling System

- Coolant surge tank
- Variable-speed hydraulically driven fan cooling system
- ▲ Reversing fan drive

Powertrain

- High-strength adjustment-free final-drive chains
- Automatic spring-applied hydraulically released wet-disc park brake
- Wet-disc brakes
- Transmission, 2 speed

Hydraulic System

- John Deere hydraulic cylinders with cushioned boom cylinders
- John Deere heat-treated, chrome-plated cylinder rods with replaceable bushings
- Connect-under-pressure auxiliary couplers
- Quick-check hydraulic fluid-level sight glass
- 1,000-hour, 5-micron hydraulic filter
- ▲ High-flow hydraulics
- Axial-piston hydrostatic pump

Electrical

- Automatic engine/hydraulic shutdown protection system
- Auxiliary hydraulics operator-presence system
- Courtesy lighting
- Deluxe instrumentation monitor with: Operator-selectable monitoring – Hour meter, engine rpm, battery voltage, diagnostics, monitor configuration, engine coolant temperature, hydraulic oil temperature / LED warning indicators – Glow plug, seat

330 P Electrical (continued)

- switch, seat belt, door open, auxiliary hydraulics, park brake engaged, 2-speed engaged, stop, low engine oil pressure, engine coolant over-temperature, battery not charging, air filter restriction, and hydraulic filter restriction
- ▲ Deluxe LED lighting package with additional cab-integrated side lights (2)
- Front and rear halogen work lights
- Triple-interlock operator-presence control system
- Backup alarm
- Battery, 950 CCA
- ▲ Hazard warning lights
- ▲ Strobe light, amber
- Horn

Operator's Station

- Deluxe cab headliner
- Electrohydraulic (EH) ISO-pattern joystick controls
- ▲ ISO-H switchable joystick controls and EH joystick performance package*
- ▲ EH 4-way controls include EH foot control, ISO joystick control, H-pattern joystick control, and ISO and foot controls
- ▲ ISO controls with programmable detents and EH boom performance package;† also includes EH joystick performance package*
- ▲ Onboard grade indication: Grade-control option delivers onboard readout within LCD monitor that provides slope of blade (cross-slope direction) and main-fall (fore/aft direction) within ±0.5-percent accuracy
- Keyless-start sealed-switch module with integrated anti-theft system and operator memory preference settings
- Electronic push-button auxiliary controls
- Pull-down adjustable lap bar
- Quick-pivot ROPS
- Rear window
- Removable top window
- ▲ Sliding/locking/removable glass side windows
- ROPS/FOPS operator structure
- ▲ Glass cab enclosure
- Seat belt, 51 mm (2 in.), retractable
- ▲ Shoulder belt, 51 mm (2 in.) or 76 mm (3 in.)
- ▲ Severe-duty cab door and wiper system
- Vinyl mechanical-suspension seat
- ▲ Vinyl air-ride seat

330 P Operator's Station (continued)

- ▲ High-back cloth air-ride seat, heated and ventilated
- 12-volt power port / Dome light / Cargo storage / Beverage holder
- ▲ Air conditioning with heater/defroster
- ▲ AM/FM radio with auxiliary input and Bluetooth® for audio streaming and hands-free calling
- ▲ Floor mat with left footrest
- Rearview mirror
- ▲ Rearview camera
- ▲ Surround View

Loader

- In-cab boom lockout to secure loader before exiting seat
- Patented John Deere Quik-Tatch™ (no grease required)
- ▲ Power Quik-Tatch
- Patented John Deere vertical-lift boom
- ▲ Hydraulic self-leveling on/off and ride control

Other

- Convenient front and rear tie-downs
- Environmental drains for all fluid reservoirs
- 14 x 17.5 14 PR Titan HD2000-II
- ▲ 14 x 17.5 NHS, Camso SKS
- ▲ 14 x 17.5 14 PR Galaxy Hulk
- ▲ 12 x 16.5 10 PR Titan HD2000-II
- ▲ 14 x 17.5 Treaded Brawler SolidFlex – Non-Pneumatic
- ▲ Chrome exhaust stack
- ▲ Engine oil/hydraulic fluid-sampling kit
- ▲ Forestry protection packages
- ▲ Heavy-duty rear grille
- ▲ Rear counterweights (available in sets of 1, 2, or 3), 78 kg (172 lb.) (each set)
- ▲ 3-point lift kit
- ▲ SMV sign kit
- ▲ Spare tire and wheel
- JDLink™ wireless communication system (available in specific countries; see your dealer for details)

[§]500-hour engine oil-change intervals when John Deere Plus-50 oil and John Deere oil filter are used.

*EH joystick performance package features switchable accelerator/decelerator, selectable propel speeds, creep control, boom- and bucket-speed settings, and 12-volt 3- and 14-pin attachment-control harness with dash-mounted 4th-function rocker switch.

†EH boom performance package features include EH bucket self-level up and down, return to dig, return to carry, and boom height kick-out.

While general information, pictures, and descriptions are provided, some illustrations and text may include product options and accessories NOT AVAILABLE in all regions, and in some countries products and accessories may require modifications or additions to ensure compliance with the local regulations of those countries.

Net engine power is with standard equipment including air cleaner, exhaust system, alternator, and cooling fan, at standard conditions per SAE J1349 and DIN 6270B, using No. 2-D fuel at 35 API gravity. Gross power is without cooling fan. Specifications and design subject to change without notice. Wherever applicable, specifications are in accordance with SAE standards. Except where otherwise noted, these specifications are based on a unit with standard equipment, full fuel tank, and 79-kg (175-lb.) operator.



MK330PAU (24-05)

 **JOHN DEERE**