

Funk™ DF250

Powershift Transmission

Industrial Drivetrain Specifications



Dimensions

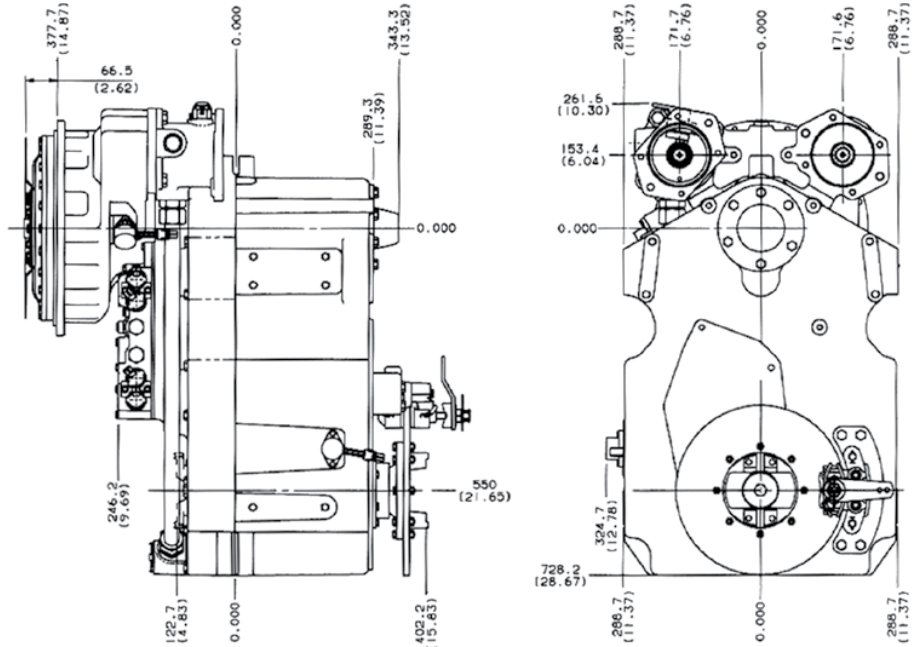

Ratings

Net input power (max)	186 kW (250 hp)
Input no load speed (max)	2600 rpm
Converter stall torque (max)	1898 Nm (1400 lb-ft)
Engine net peak torque (max)	949 Nm (700 lb-ft) direct drive

General data

Rotation	
Input	Counterclockwise
Output	Forward, same as input
	Reverse, opposite input
	550 mm (21.65 in) drop
Approximate dry weight	680 kg (1500 lb)
Mounting	Engine, midship, or remote
Speeds	4F/4R
	8F/4R
	11F/3R

Remote-mounted DFR

The front housing of our DF150 and DF250 products is our DFR engine-mounted PTO, which can also be purchased as a stand-alone product. The DFR mounts to the engine and can be used to power the transmission, as well as a variety of external equipment.



Pump drives

Rotation (viewing drive pad)	Counterclockwise
Ratio (engine speed to pump speed)	0.947:1 or 0.837:1
Mounting and spline size	SAE A, B, or C
Disconnect available for mounting size	SAE C
Power (max intermittent)	149 kW (200 hp)
Power (max continuous)	52 kW (70 hp)

Gear ratio ranges

DF250	1st	2nd	3rd	4th
4x4	4.78	2.60	1.42	0.77
4x4	5.98	3.03	1.51	0.76

DF250	F1	F2	F3	F4	F5	F6	F7	F8	R1	R2	R3	R4
8x4	6.01	4.28	3.07	2.19	1.51	1.08	0.77	0.55	6.01	3.07	1.51	0.77
8x4	8.04	5.73	4.11	2.93	2.03	1.44	1.04	0.74	8.04	4.11	2.03	1.04

DF250	F1	F2	F3	F4	F5	F6	F7	F8	F9	F10	F11
11X3	5.36	3.81	2.90	2.32	1.99	1.65	1.42	1.26	1.08	0.790	0.68

R1	R2	R3
5.36	3.81	2.90

Features and benefits

Flexible drive types

- Regardless of vehicle design, the DF250 has the input drive you require.
- Choose torque converters of varying performances or select an efficient direct drive, the most economical design for both machine and operating costs.

Flexible gearing

- Numerous configurations are available from 4-speed up to 8-speed.
- The customizable control also offers the ability to disable gear ranges permanently – at the factory with wiring harness changes, or simple flip of a switch.

Premium shift quality

- Industrial vehicles perform a variety of operations with multiple duty cycles.
- DF250 shift quality is optimized with temperature and load compensation, so regardless of the job or the operator, maximum comfort and consistency are achieved.

Electronic control system

- Your application will have a control program that you design.
 - Shift lever – Bump-style is standard, but other styles can be accommodated.
 - Engine overspeed protection – OEM-specified for any engine and/or application.
 - Clutch protection – Prevents transmission damage due to rough operation.
 - Shuttle protection – Clutch protection and optimization of shuttle operations – J1939 CAN communications – Enables interactivity with vehicle components including Multi-Feature CAN displays.
 - Self-calibration – Optimized shift quality can easily be initiated by the end-user – Auto-shift option – Automatic shifting in optimum conditions for maximum fuel efficiency and transmission life.