

A New Anti-Jamming Method for GNSS Receivers

Jerry Knight, Charles Cahn and Sidharth Nair

TABLE OF CONTENTS

1	Summary	2
2	Introduction	2
2.1	<i>Test Modes</i>	2
2.2	<i>Jamming Test Setup</i>	3
2.3	<i>Calibration of the Spirent GNSS Simulator</i>	3
2.4	<i>Calibration of the Noise Com and HP Generators</i>	4
2.5	<i>AGC Measurements</i>	5
2.6	<i>C/N0 Measurements</i>	5
2.7	<i>NCT-2100D Receivers</i>	6
3	CW Jamming Tests (Varying J/S – Constant GPS Signal)	6
4	CW Jamming with Varying GPS Signal Strength	8
5	CW Sweeping Tests (Spectral lines)	11
6	CW Jamming with Varying Center Frequency	18
7	Pulse Jamming	21
8	PN Jamming	23
9	Chirp Jamming	27
10	Pulsed Broadband Jamming	28
11	Broadband Jamming	29
12	Frequency sweep – L1 + Doppler offset	34
13	Frequency sweep – L1 + 0.5 * Doppler offset	38

1 Summary

The Sapphire receiver contains several features designed to provide resistance to various forms of jamming signals.

- The RF section front end tolerates very powerful jamming signals without burnout. A 32 MHz wide SAW filter with greater than 60 dB rejection is included in the RF section to reject out of band jamming signals.
- The system AGC and ASIC implement a new invention (patent pending) that detects the presence of in-band continuous wave jamming and adjusts the receiver's sampling strategy so much of the jamming power is deleted and much of the GNSS signal power is retained.
- The anti-pulse jamming techniques from the receiver NavCom designed for a [L1 aviation receiver](#) are included. This best-in-industry technique automatically detects the presence of pulse jamming (a jamming signal that turns on and off at a high rate, like cell phone communications) and ignores samples that contain jamming and processes those that don't. This technique is one feature that allowed the [L1 aviation receiver](#) to be the first fully certified aviation receiver that is compliant with DO 229C.

The following report records the results of experiments that are designed to stress and break the receiver. The key results of these tests are:

- The receiver will reject out-of-band jamming signals as large as +30 dBm.
- The receiver provides rejection of in-band pulse jamming as strong as -30 dBm while only reducing signal tracking ability in proportion to the duty cycle of the jamming signal. (Samples are lost while the jamming pulse is present).
- The receiver will track in-band CW signals with jamming to signal (J/S) power ratios of up to 60 dB.
- The receiver has the ability to detect the jamming signals and estimate their strength by monitoring the AGC voltage.
- The level of resistance to jamming by in-band CW signals is reduced if the frequency of the jammer matches one of the C/A code spectral lines or matches the L-band equivalent of the reference oscillator frequency offset. This is a known weakness of the C/A signals. The new L2 and L5 GPS signals have eliminated this weakness.

2 Introduction

2.1 Test Modes

The anti-jamming feature is a critical aspect of the digital ASIC. These tests provide a comprehensive look into the receiver's jamming performance when subject to various types of interference. The different test modes are:

- CW Jamming Tests (Varying J/S – Constant GPS Signal)
- CW Jamming with Varying GPS Signal Strength
- CW Sweeping Tests (Spectral lines)
- CW Jamming with Varying Center Frequency
- Pulse Jamming
- PN Jamming
- Broadband Pulse Jamming
- Broadband Jamming

This series of tests use the L1 band with center frequency 1575.42 MHz. Similar results are anticipated for other GNSS bands, which were not tested due to limitations of the test equipment.

2.2 Jamming Test Setup

The test setup for the jamming tests is as shown in Figure 1. A Noise Com noise generator or an HP signal generator generates the jamming signals. The two generators are calibrated such that their output powers are equal.

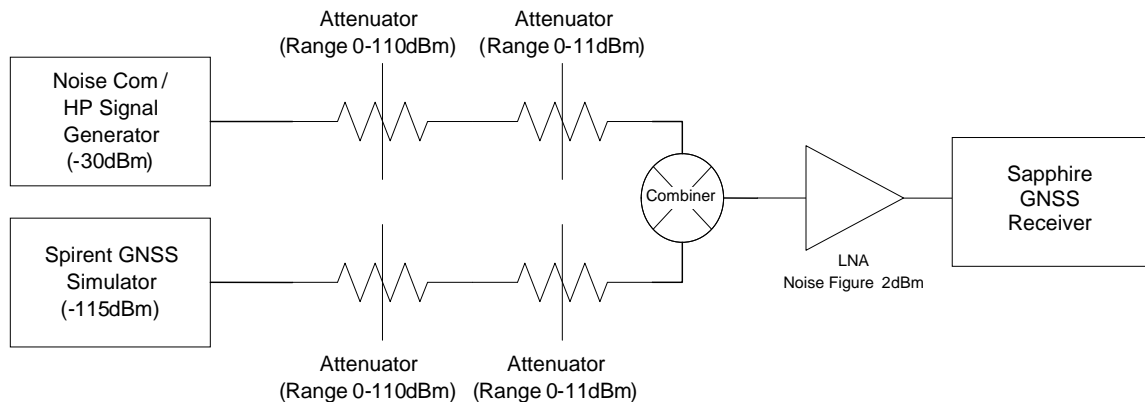

Figure 1 Jamming Test Setup

The strength of the jamming or satellite signals is adjusted by varying the external attenuators.

2.3 Calibration of the Spirent GNSS Simulator

The strength of the GPS signal generated by the Spirent simulator is calibrated using the simulator's single channel utility mode. The simulator is configured to broadcast the L1 carrier with no code modulation, the signal attenuators are set to zero, and the other signal generators are turned off. The strength of the output signal is measured with a spectrum analyzer (Figure 2).

- CW Signal measured on Spectrum Analyzer = -92 dBm

- Probe Gain = 23 dBm
- Actual signal level = $-92 - 23 = -115$ dBm
- Sapphire Pre-amp noise figure = 2 dBm
- Noise floor = -174 dBm (Assumed theoretical noise for room temperature)
- Expected $C/N_0 = -115 - (-174 + 2) = 57$ dB-Hz

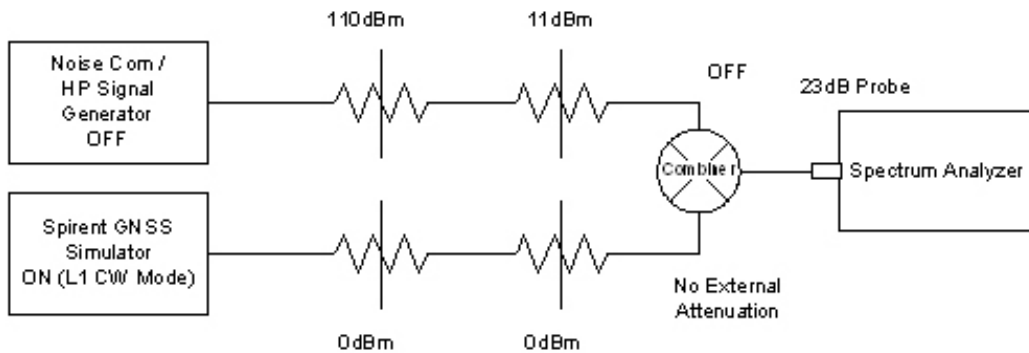

Figure 2 Spirent Calibration

We then turn on the C/A code in this single channel utility mode and observe the C/N_0 measured on Sapphire, iTC and NCT-2000 series engines. See Table 1. The approximate 4 dB difference between the C/N_0 measured by the spectrum analyzer and the C/N_0 estimated by the receivers is believed to be due to signal losses in the Spirent simulator.

Engine	Displayed L1 C/A C/N_0
iTC	52 dB/Hz
NCT-2100D	53 db/Hz
Sapphire	51 dB/Hz

Table 1 Spirent Calibration

2.4 Calibration of the Noise Com and HP Generators

The power of the Noise Com generator is measured directly with an Agilent power meter. When the output power is set to -30 dBm, the measured power is approximately -30.2 dBm. Similarly, when the HP Signal generator is set to -30 dBm, the measured power is -30.3 dBm. The difference between the instrument settings and the measured power levels is believed to be due to connector and cable losses (Figure 3).

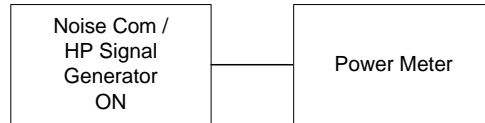

Figure 3 Power Meter

2.5 AGC Measurements

The Sapphire anti-jamming hardware varies the RF section AGC voltage so the ratio of large (non-zero) and small (zero) samples is constant. As the jamming level is increased the size of the average sample increases so the AGC gain is decreased by reducing the AGC reference voltage.

During each of the jamming tests the applied RF section AGC voltage was measured with a volt meter and recorded.

2.6 C/N₀ Measurements

The C/N₀ measurements output by the Sapphire receiver are an estimate of the signal-to-noise ratio in a one-Hertz bandwidth at the interface between the antenna element and the first stage low noise amplifier. They are derived from the Sapphire receiver's I and Q measurements.

The raw one millisecond I and Q accumulations are summed (coherently integrated) for the 20 ms GPS bit time. The BPSK modulated data bits are stripped by taking the absolute value of the I and Q sums.

It is assumed, since the receiver is tracking the GPS signal with a Costas loop, that I sums contain all of the signal power and the Q sum is just noise. This assumption produces a pessimistic signal-to-noise ratio at low signal to noise ratios when the Costas loop phase noise is near break-lock.

The ratio of the absolute value of the I sum divided by the absolute value of the Q sum is used to measure the signal-to-noise ratio in a 50 Hz (20 ms long bit) bandwidth. The ratio is converted to signal-to-noise in a one Hertz bandwidth, C/N₀, by adjusting for bandwidth and known statistical properties of absolute values.

The signal-to-noise ratio derived directly from I and Q measurements represents the signal and noise at the very end of the receiver's data processing chain and includes all losses in the first stage amplifier, RF down conversion and digital signal processing. It is converted to the C/N₀ at the input to the first-stage amplifier by adding 4.3 dB-Hz to the C/N₀ estimated from the I and Q sums. This adjustment compensates for processing losses in the amplifier and receiver processing chain. These receiver losses were measured in earlier stages of Sapphire receiver testing as follows:

- First stage LNA noise figure 2.0 dB
- RF section processing loss 1.0 dB
- Digital section processing loss 1.3 dB

2.7 NCT-2000 Series Receivers

During several of the jamming tests the test signal is split equally and fed to a Sapphire and a reference NCT-2100D receiver. At each jamming level the C/N_0 and break lock condition displayed by the NCT-2100D receiver is recorded.

The NCT-2100D carrier tracking loops use a 40 Hz Costas loop while the Sapphire loops use a 20 Hz Costas loop. Theoretically, the narrower Sapphire loop should tolerate 3B stronger jamming.

The NCT-2100D receiver provides jamming resistance comparable to most dual frequency GPS receivers by employing four bit A/D samples. Classically, as a design rule of thumb, each bit of A/D provides up to 6 dB of anti-jam protection. The cost of processing extra A/D bits is high because the number of bits required to implement phase rotation and correlation in the digital ASIC increases in proportion to a power of the number of bits.

3 CW Jamming Tests (Varying J/S – Constant GPS Signal)

The first series of tests mixes the non-attenuated GPS signal with a variable power continuous wave (CW) jamming signal. The frequency of the jamming signal is 1575.42 MHz. The carrier frequency of the GPS satellite is set at a slight offset to the frequency of the CW signal to avoid C/A code spectral line effects (spectral line interference will be investigated in a later test). At each jamming power level the C/N_0 and AGC voltages are measured.

The test setup is shown in Figure 4. The CW jamming signal at L1 frequency from the Noise Com generator is combined with an L1 C/A signal from the Spirent simulator. The signal attenuation on the GPS signal is set to zero. The CW attenuation is initially set at 110 dBm and slowly reduced. As the attenuation is varied the C/N_0 and AGC voltage for the Sapphire receiver and the C/N_0 displayed by a reference NCT-2100D receiver are recorded.

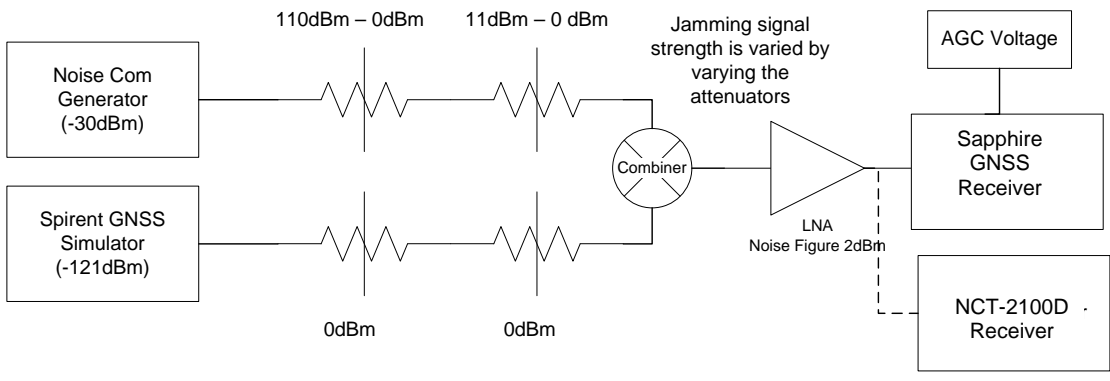

Figure 4 CW Jamming Test

Figure 5 shows the simultaneous performance of the Saphire and NCT-2100D receivers under CW interference jamming. The NCT-2100D loses signal lock at a J/S ratio of approximately 44 dB (with a displayed C/N_0 of 38 dB-Hz). Saphire fails at a J/S ratio of 59 dB (with a displayed C/N_0 of 24 dB-Hz); a marked improvement for jamming rejection of approximately 15 dB over the NCT-2100D receiver. 3 dB of the difference is due to the unique tracking loop bandwidths used by the two receivers (40 Hz Costas loop for NCT-2100D and 20 Hz for Saphire). The remaining 12 dB improvement is due to the new Saphire anti-jamming techniques.

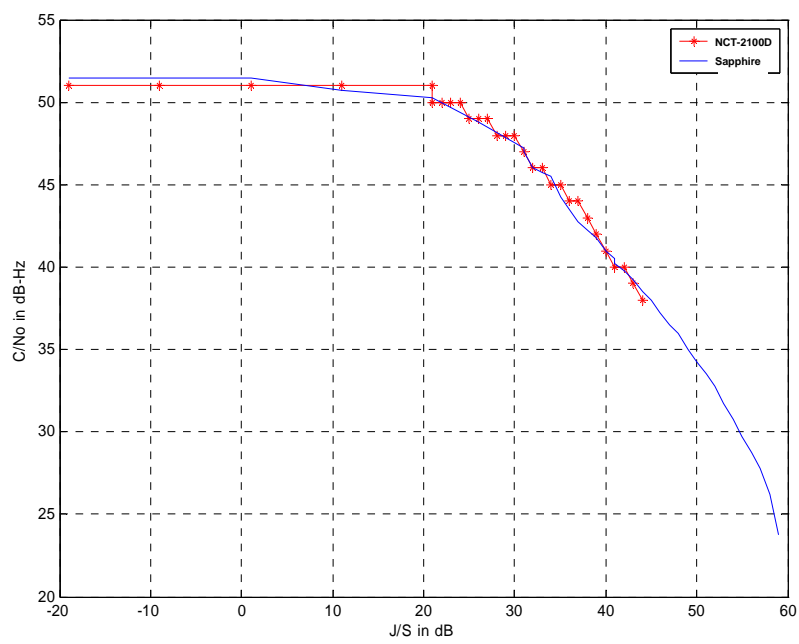

Figure 5 CW Jamming - Saphire and NCT-2100D

4 CW Jamming with Varying GPS Signal Strength

This series of tests is similar to the first test except the signal strength of the GPS signal is varied at the start of each new test. The test setup shown in Figure 6 is very similar to that of the first test. At the start of the test CW jamming interference is set to -110 dBm. The jamming frequency is 1575.42 MHz. During the test run, the strength of the CW signal is increased until the receiver breaks lock. The strength of the GPS signal is different for each run, but is held constant during the run. The carrier frequency of the GPS satellite is set at a slight offset to the frequency of the CW signal so that it avoids C/A code spectral line effects. The AGC voltage and the displayed Sapphire C/N_0 are recorded as each jamming level. The NCT-2100D receiver data was not recorded during these tests.

Figure 6 CW Jamming - Varying GPS Signal Strength

Figure 7 plots the Sapphire displayed C/N_0 versus the strength of the jamming signal. The receiver loses lock when the jamming is increased beyond the right hand end of each curve. On the left hand side of the graph there is essentially no jamming present and the displayed C/N_0 is equal to the un-jammed C/N_0 of the simulated satellite signal at the input to the antenna amplifier.

As the jamming level is increased beyond -110 dBm, the sum of jamming plus thermal noise begins to increase and the receiver's estimate of C/N_0 begins to decrease. The shape of each curve is very similar and in each case the receiver loses lock when the displayed C/N_0 is about 25 dB-Hz.

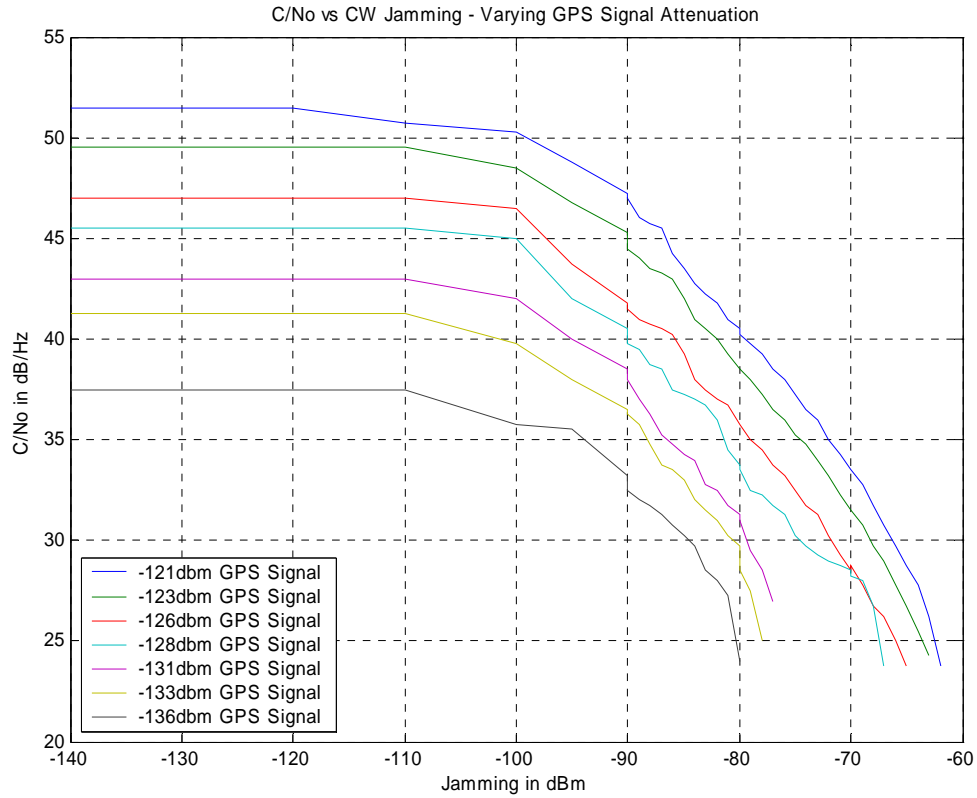

Figure 7 C/N_0 vs. CW Jamming

Figure 8 displays the same data, but the X-axis is now the ratio of the strengths of the jamming signal and satellite signal (J/S). As the strength of the jamming is increased it overwhelms the thermal noise and effectively decreases the signal to noise ratio of the measurements and the displayed C/N_0 decreases accordingly. The receiver loses lock at a displayed C/N_0 of 25 dB-Hz and a J/S of approximately 60 dB for all signal strengths.

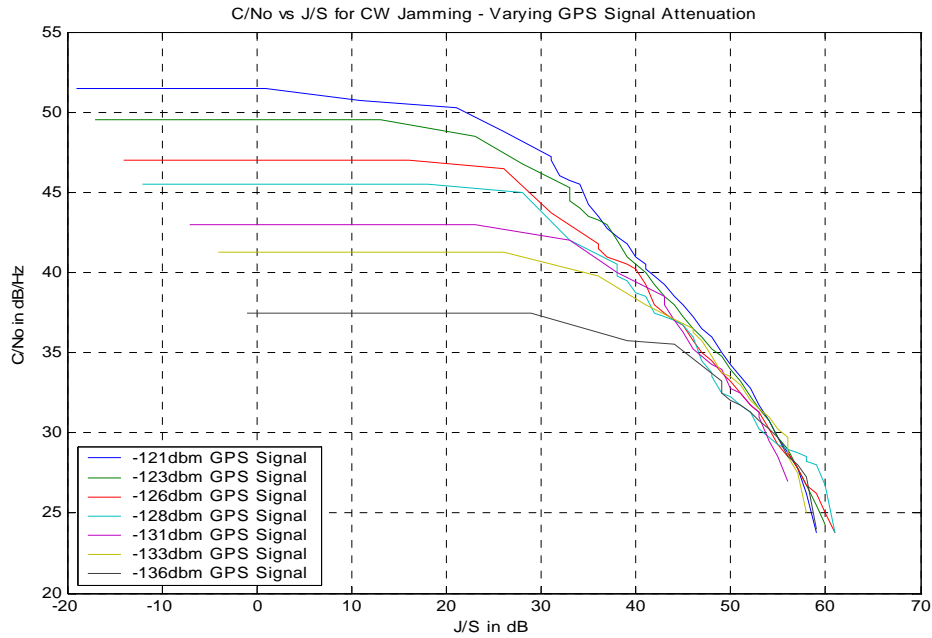

Figure 8 C/N_0 vs. J/S - Varying GPS Signal Strength

The AGC voltage behaves identically for each GPS signal level. It is a consistent indicator of the level of jamming for all satellite strengths. This property may be useful in future design of jamming detection etc. (Figure 9).

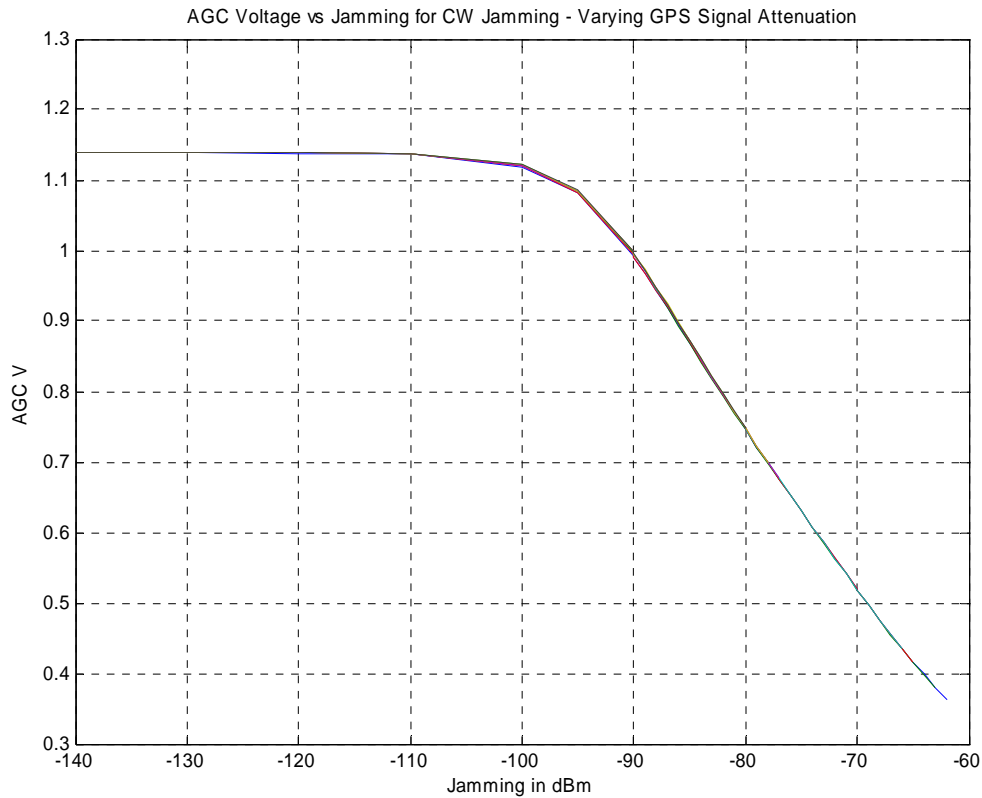

Figure 9 AGC vs. CW Jamming

5 CW Sweeping Tests (Spectral lines)

The next series of tests investigate the effects of the frequency of the jamming signal in both Sapphire and NCT-2100D receivers. In preparation for the test the spread spectrum of an extremely strong simulated GPS C/A code for PRN 1 was displayed with a spectrum analyzer. A strong non-central spectrum line was found at 1575.32223 MHz.

During each test the power (-121 dBm) and frequency of the satellite are held constant.

A variable frequency CW signal from the HP signal generator is used to create the jamming signal (see Figure 10). The frequency of the jamming signal varies from 1575.32213 MHz to 1575.32233 MHz in 1 Hz steps so that it crosses the C/A spectral line during the sweep. The dwell time for each step is 5 seconds. The power of the CW signal in the first run is -100 dBm. It is increased in each subsequent run.

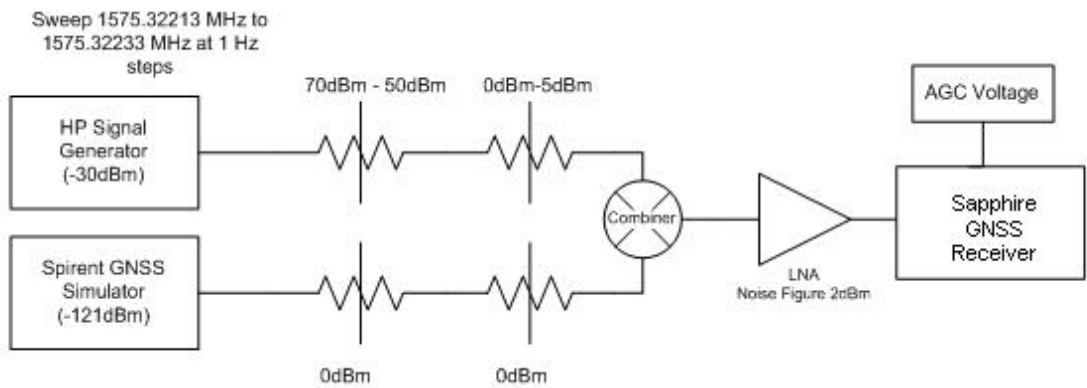

Figure 10 Sweep Test Setup

The HP generator output frequency is not output or displayed by the generator, and therefore can not be recorded. Instead, the generator is placed in a continuous sweep mode so that when the highest frequency is reached, the generator resets to the lowest frequency and repeats the sweep. This ensures the entire frequency range will be tested every 1000 seconds. However, the location of the spectral line as a function of run time varies from test to test. Each test was run for a minimum of 1000 seconds or until the receiver lost lock.

The power of the jamming signals and a summary of the test results are shown in Table 2. The jamming signal power is -100 dBm in the first test and is increased in subsequent tests until the receiver loses lock. Compared to the non-spectral line tests, signal is lost when the jamming is 24 dB lower.

Results for the NCT-2100D receiver are similar to those for the Sapphire receiver. Both lose lock when the J/S is about 30 dB.

The reduced anti-jamming capability at C/A code spectral lines is expected and is caused by a weakness in the C/A code itself. Normally, the 1 MHz C/A code spreads the power of the jamming signal over 1 MHz and in essence makes it look like thermal noise with power equal to 60 dB less than the CW signal.

Jamming Strength (dBm) (HP signal Generator internal = -30dBm)	J/S in dB	Status
-70 + (-30) = -100	-100-(-121) = 21	LOCK
-65 + (-30) = -95	-95-(-121) = 26	LOCK
-64 + (-30) = -94	-94-(-121) = 27	LOCK
-63 + (-30) = -93	-93-(-121) = 28	LOCK
-62 + (-30) = -92	-92-(-121) = 29	LOCK
-61 + (-30) = -91	-91-(-121) = 30	LOCK
-60 + (-30) = -90	-90-(-121) = 31	Loss of LOCK
-55 + (-30) = -85	-85-(-121) = 36	Loss of LOCK

Table 2 Frequency Sweep Test Results

Due to the 1 KHz repetition rate of the C/A code, spectral correlation lines occur at integer multiples of 1 KHz from the center carrier frequency. At the spectral lines the jamming signal appears to be a duplicate C/A signal with the same C/A code as the satellite but with power 30 dB less than the jamming signal. The second signal stresses the carrier tracking loops and causes them to break at a power density that is less than thermal noise. As a result the loops lose lock before Sapphire's AGC-based anti-jamming technique is activated.

Figure 11 through Figure 18 depict the variation of the observed C/N_0 and Costas Ratio (CR) over the sweep duration. The Costas Ratio is defined as $(I^2 - Q^2)/(I^2 + Q^2)$. Mathematically, this is equal to cosine of twice the average phase tracking angle error during the I, Q integration interval. A Costas ratio of 1.0 indicates perfect tracking and -1 indicates an average 90 degree tracking error. A Costas Ratio less than 0.5 indicates a tracking problem. The J/S level in each plot is indicated in the title. The jamming level is lowest in the first figure and increases in each subsequent figure.

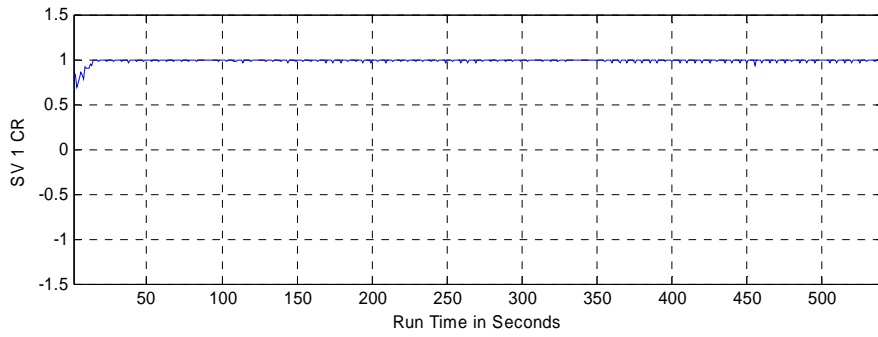
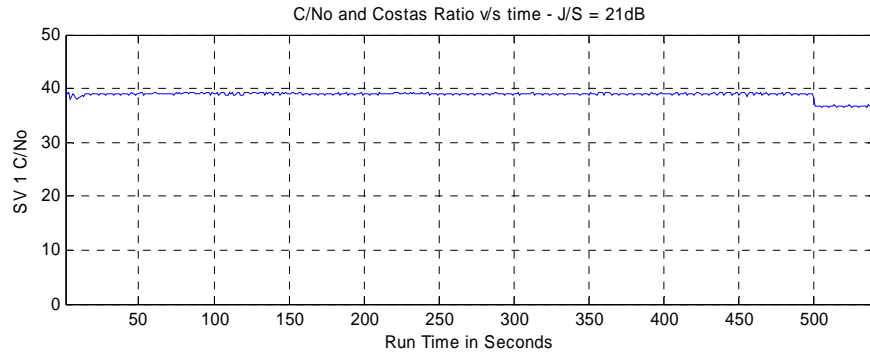

Figure 11 J/S 21 dB

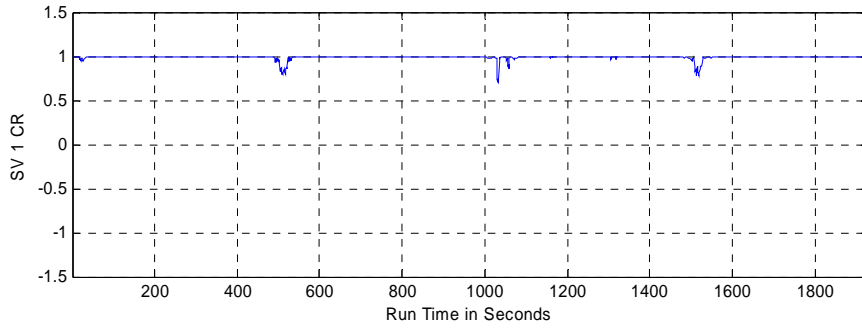
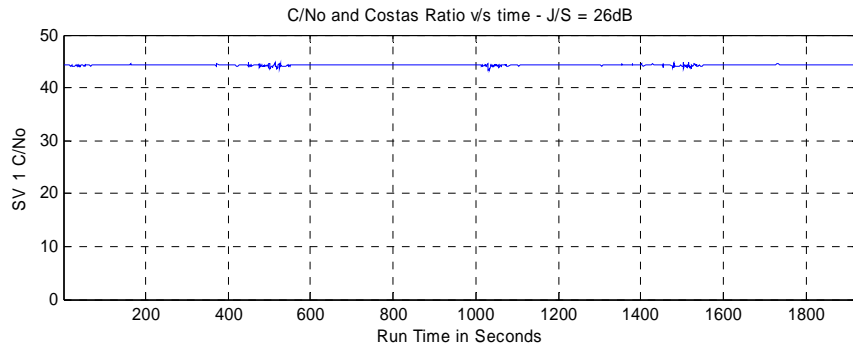

Figure 12 J/S 26 dB

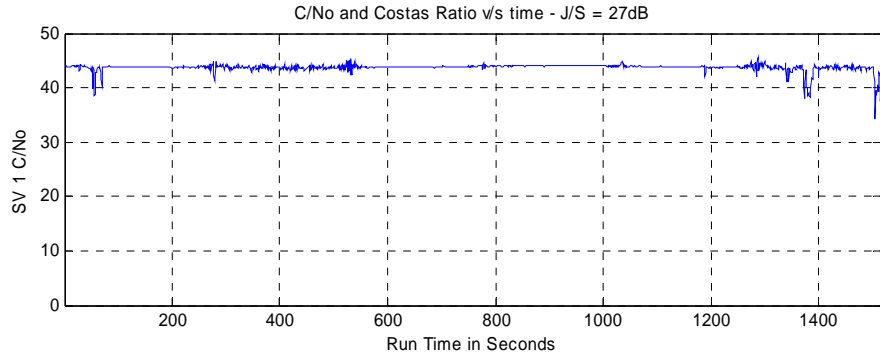

Figure 13 J/S 27 dB

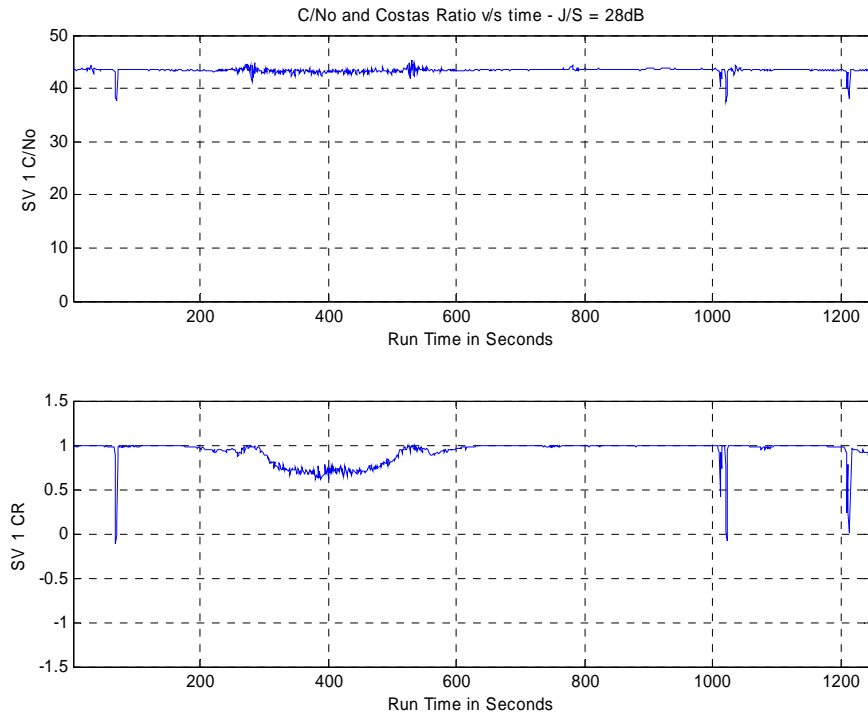

Figure 14 J/S 28 dB

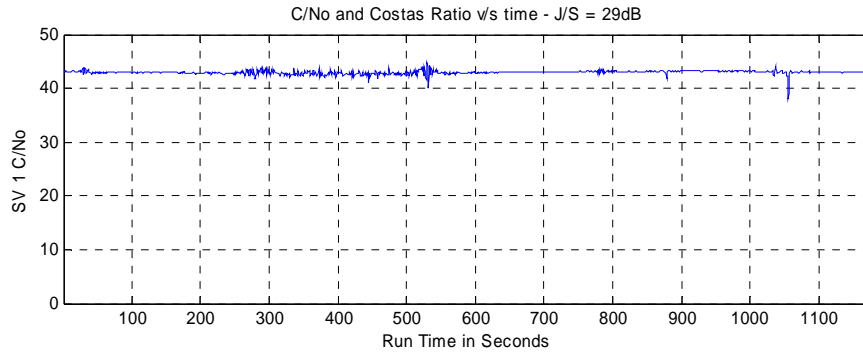

Figure 15 J/S 29 dB

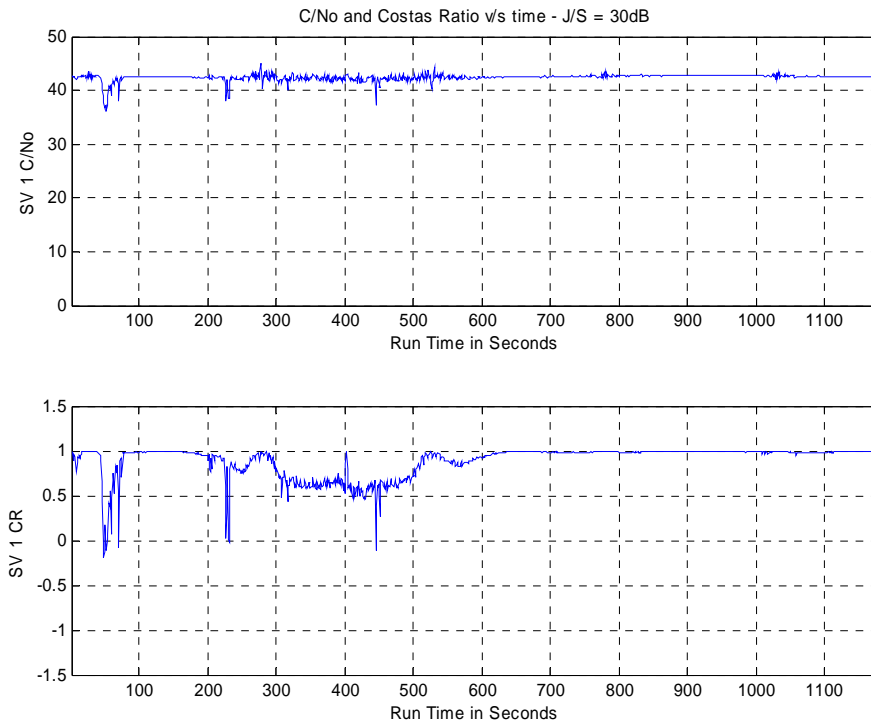

Figure 16 J/S 30 dB

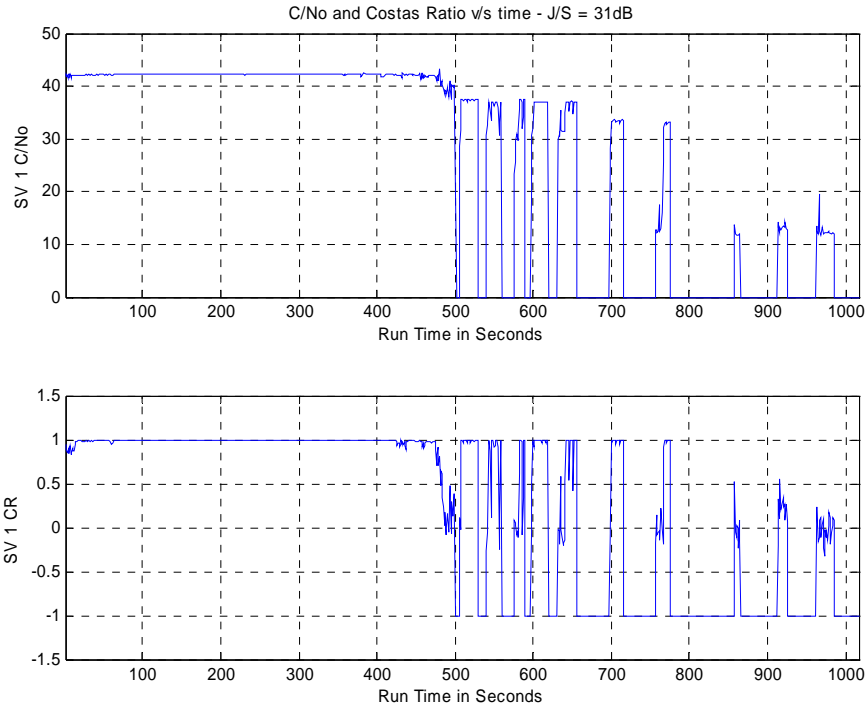

Figure 17 J/S 31 dB

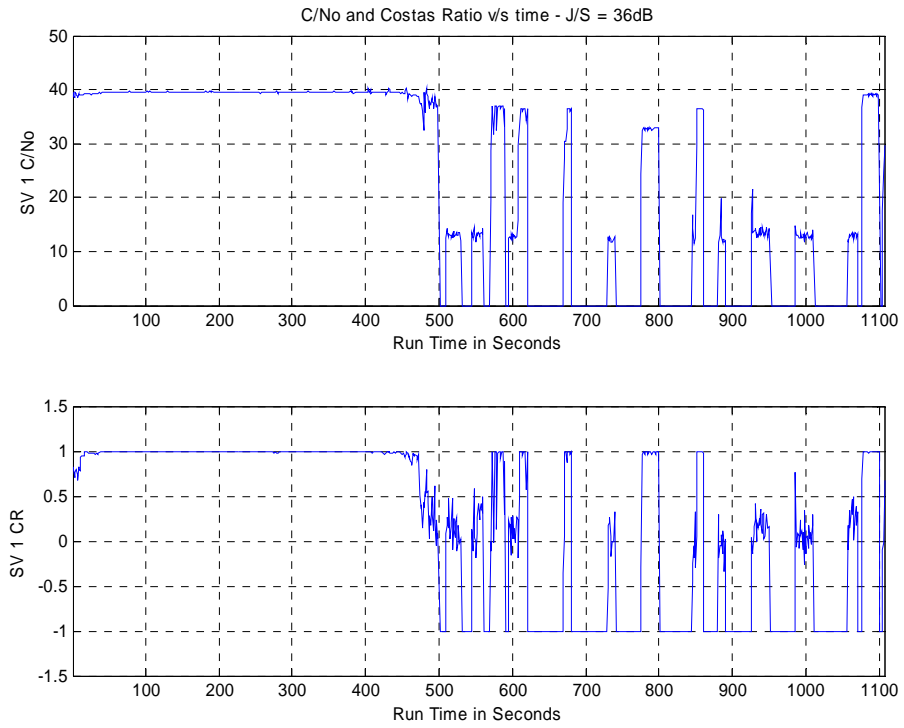

Figure 18 J/S 36 dB

6 CW Jamming with Varying Center Frequency

This test varies the center frequency of the Noise Com generator to observe the C/N_0 and AGC variations. The test setup is shown in Figure 19.

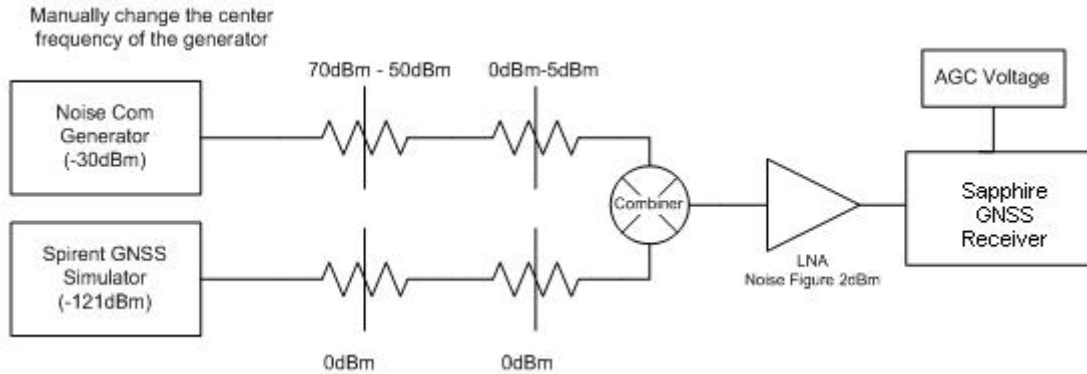

Figure 19 CW Jamming – Test Setup

Figure 20 and Figure 21 display plots for C/N_0 and AGC versus jamming power for various jamming frequencies. In these tests the center frequency of the jammer is within the 30 MHz pass band of the SAW filter. Figure 22 and Figure 23 show jamming frequencies outside the pass band. We expect the SAW filter to attenuate a jammer outside the 1560 to 1590 MHz pass band by 60 dB or more. Accordingly, less AGC adjustment is required to counteract the jamming.

The peculiar shape of the C/N_0 and AGC voltage curves in Figure 22 and Figure 23 indicate one or more portions of the RF sections are behaving non-linearly when the jamming power is very strong. $J/S = 130$ dB for a satellite signal strength of -121 dBm means the jammer signal strength is +9 dBm. Significant limiting and non-linear performance is probably occurring in the RF front end.

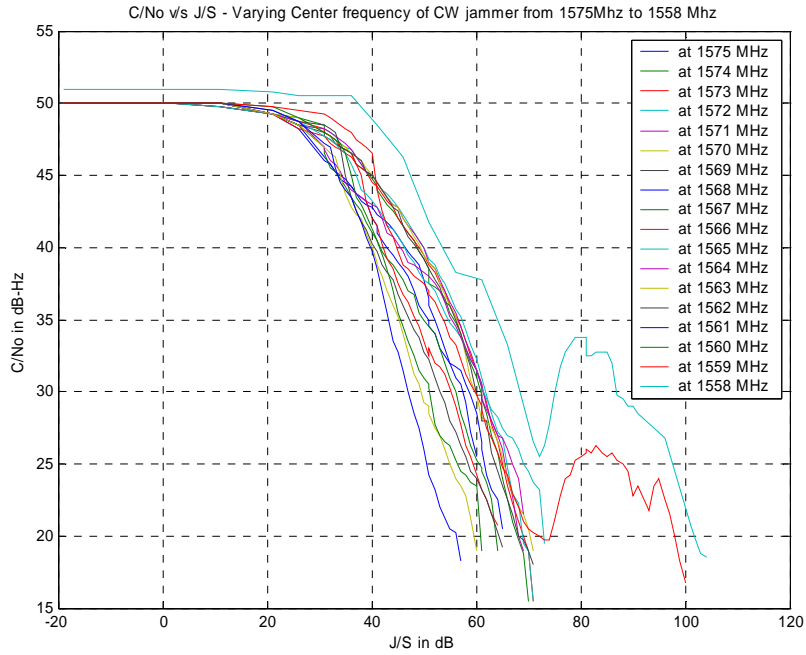

Figure 20 - C/N₀ vs. J/S - Varying Center Frequency – In Band

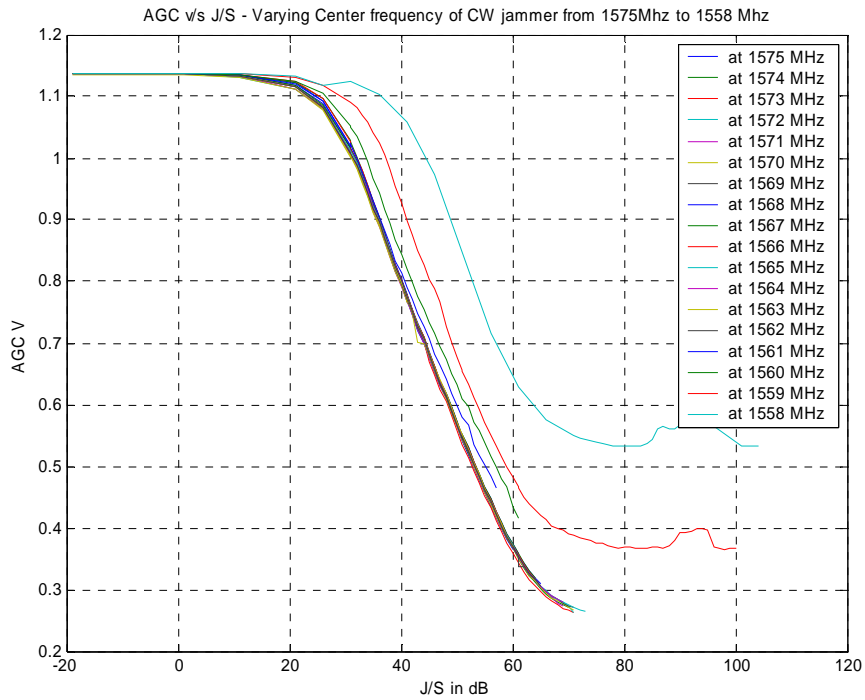

Figure 21 - AGC vs. J/S - Varying Center Frequency – In Band

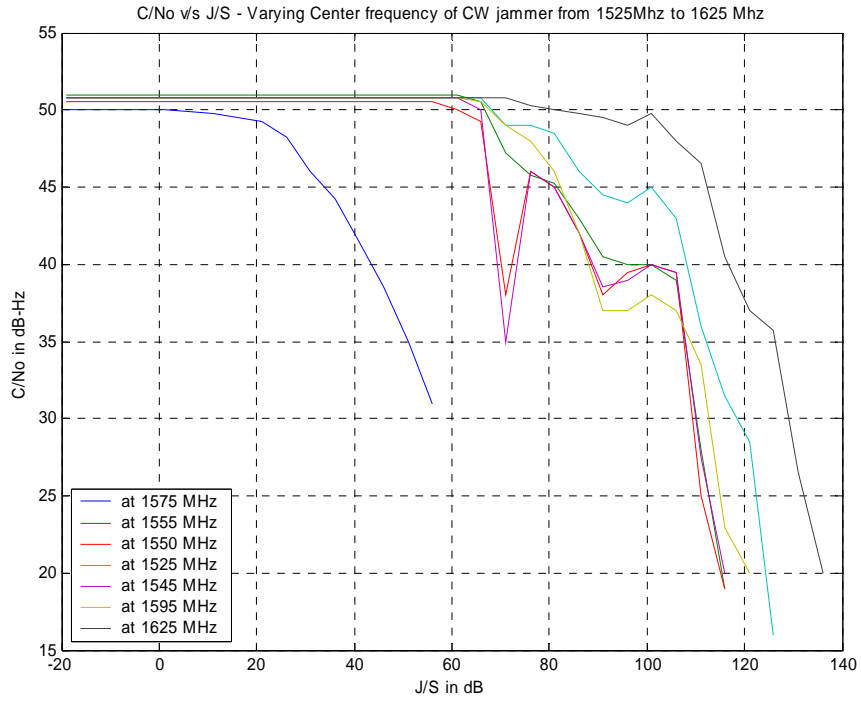

Figure 22 - C/N₀ vs. J/S - Varying Center Frequency – Out of Band

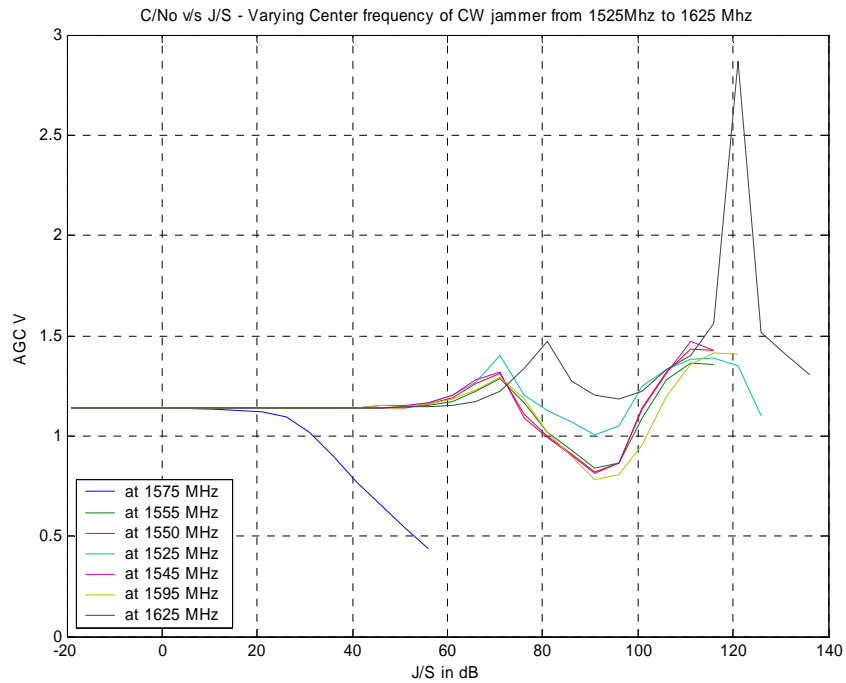

Figure 23 - AGC vs. J/S - Varying Center Frequency – Out of Band

7 Pulse Jamming

In the next series of tests the Noise Com generator is configured to create pulse jamming signals with duty cycles from 10% to 50% and a repetition interval of 1 ms. The signal attenuators are initially set so the strength of the jamming signal is -135 dBm. The jamming is then increased and the change in C/N_0 and AGC voltage are observed. The pulse jamming is slightly offset from the satellite signal carrier frequency to avoid spectral line interference (Figure 24).

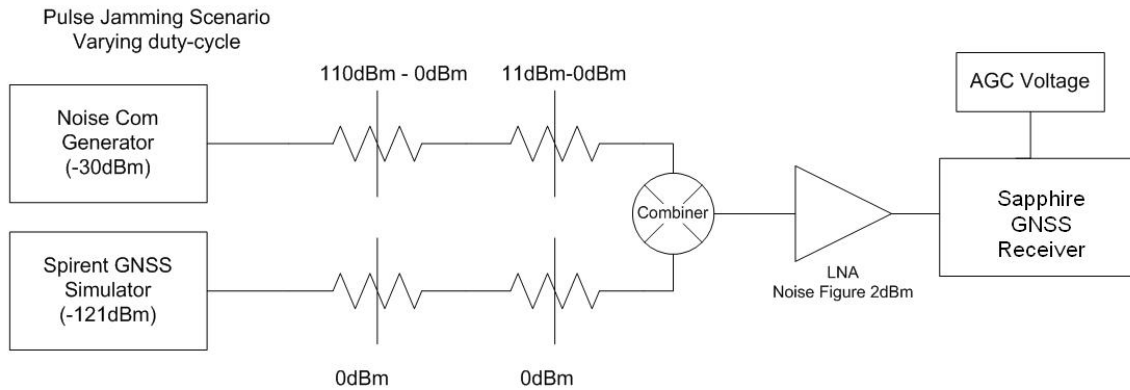

Figure 24 Test Setup for Pulse Jamming

A brief summary of the results is shown in Table 3 below. The receiver is very effective at rejecting pulse jamming detects and corrects for pulse jamming. The receiver is able to maintain phase lock in the presence of very strong jamming unless the duty cycle is greater than or equal 40 percent and J/S is greater than +95 dB.

Duty Cycle	Result	J/S dB at failure
10 %	Working	
20%	Working	
30 %	Working	
40 %	Failed	121
50%	Failed	95

Table 3 Pulse Jamming Test Results

The receiver's C/N_0 estimate and the observed AGC voltage for each of the pulse jamming tests is shown in Figure 25 and Figure 26. Pulse jamming has little effect on the receiver until the J/S increases above 80 dB.

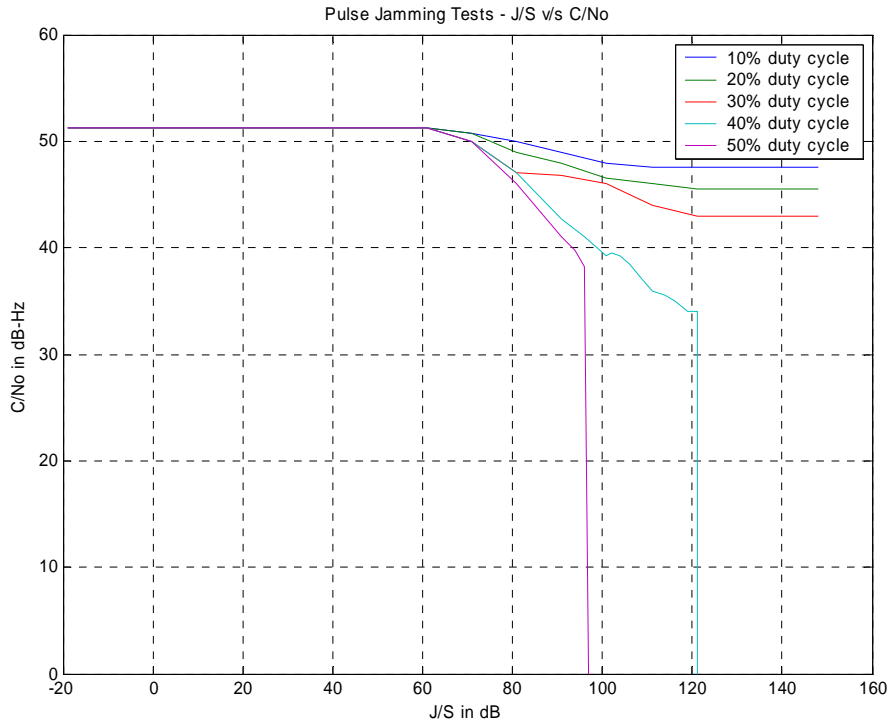

Figure 25 Pulse Jamming Test C/N_0 vs. J/S

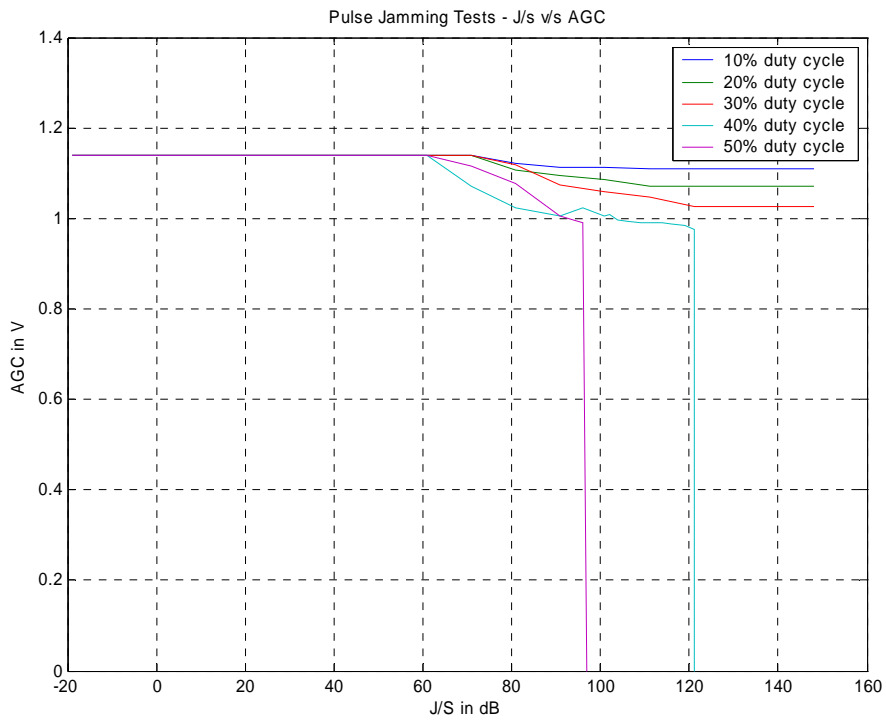

Figure 26 Pulse Jamming Test AGC vs. J/S

8 PN Jamming

The next series of tests examine the effects of a jammer that is encoded with a pseudorandom code. The jamming strength is adjusted by varying the attenuator settings. The satellite strength is constant during each run, but is varied between runs by adjusting the attenuator settings. The setup is as shown in Figure 27. In the first set of runs, a GPS P-Code (known to be a close simulation of a random bit sequence) is generated with a 10 MHz clock and BPSK modulated onto a 1575.42 MHz carrier by an HP signal generator. The P-code is generated by an FPGA evaluation board. In the second set of runs, the P-Code is clocked at 1 MHz and BPSK modulated onto the 1575.42 MHz carrier. The P-code is generated by a 1.0 MHz GPS P-code generated by a programmable FPGA evaluation board.

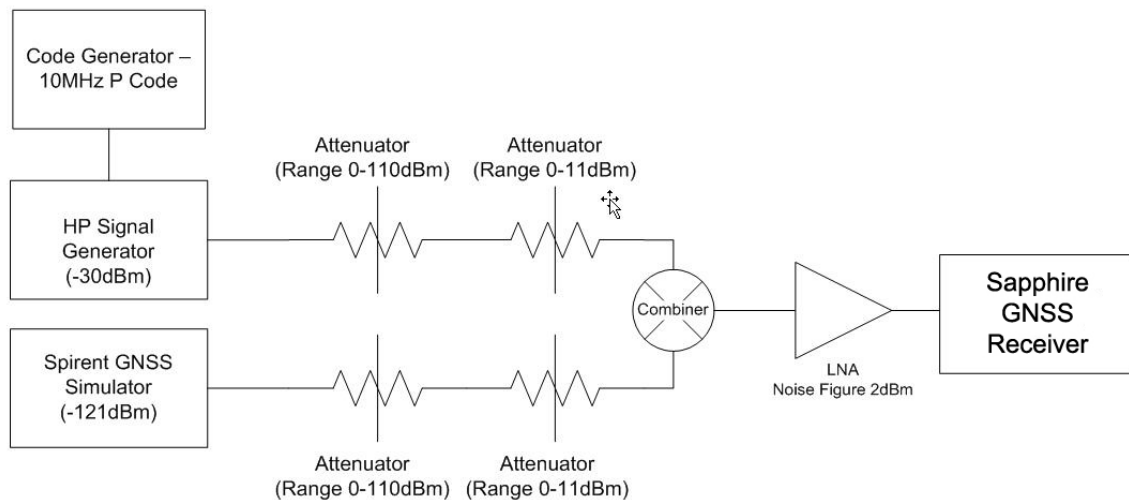

Figure 27 PN Jamming Test Setup

The performance of the 10 MHz jammer (Figure 28, Figure 29 and Figure 30) and the 1 MHz jammer (Figure 31, Figure 32 and Figure 33) closely match the results from the CW jamming tests (Figure 7, Figure 8 and Figure 9).

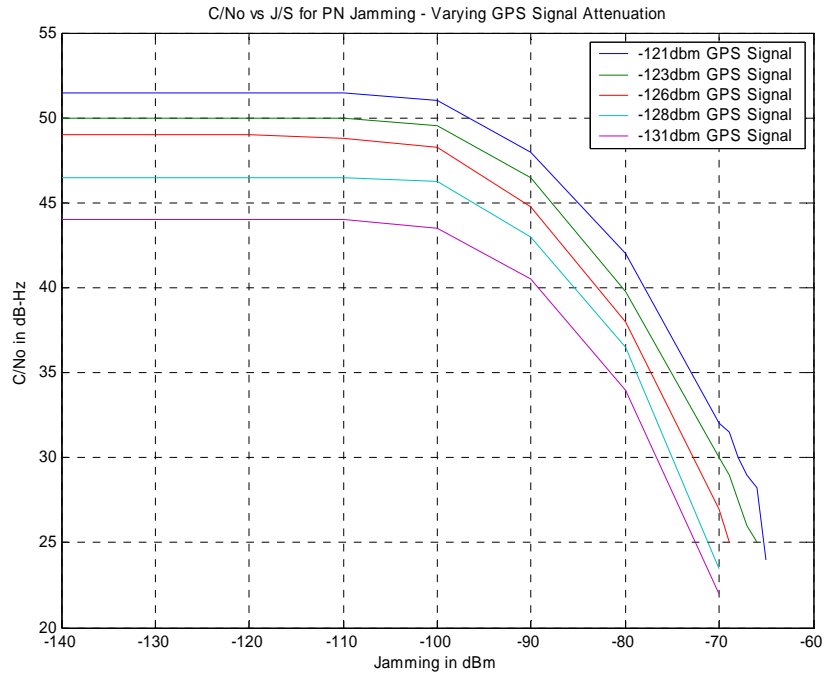

Figure 28 C/N₀ vs. 10 MHz PN Jamming

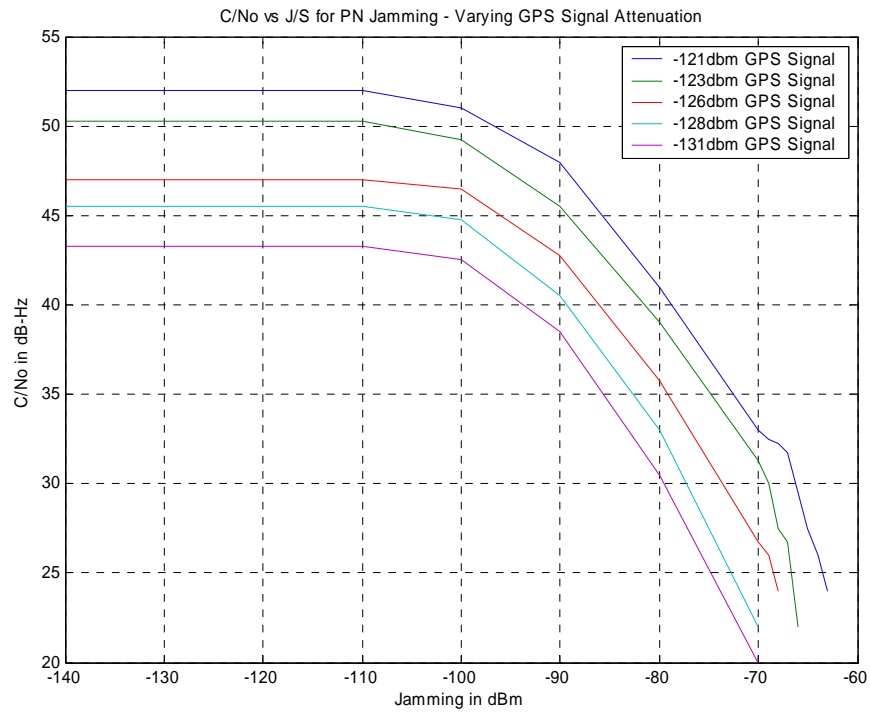

Figure 29 C/N₀ vs. J/S for 10 MHz PN Jamming

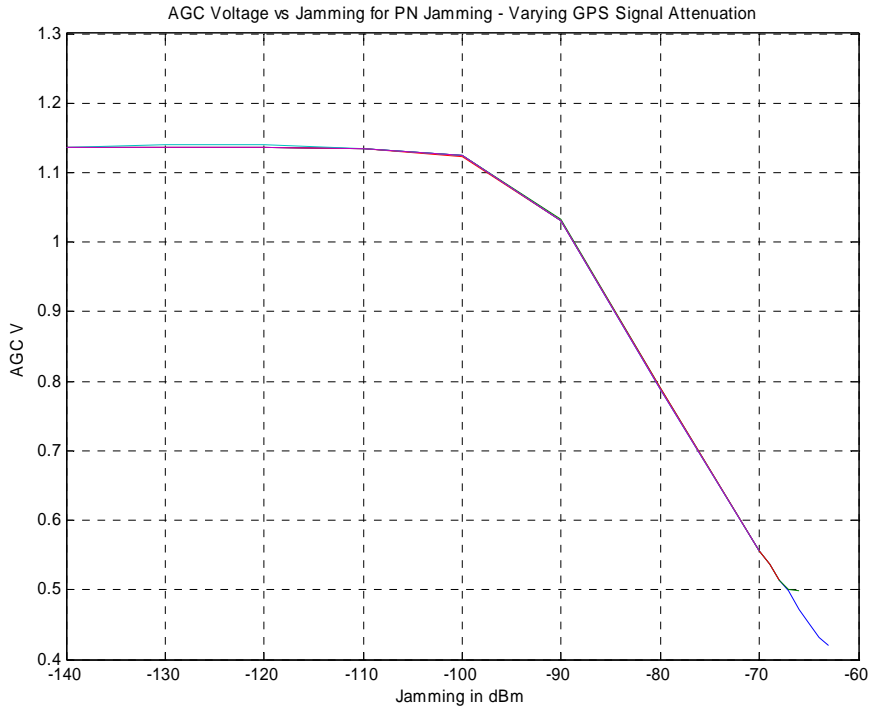

Figure 30 AGC vs. 10 MHz PN Jamming

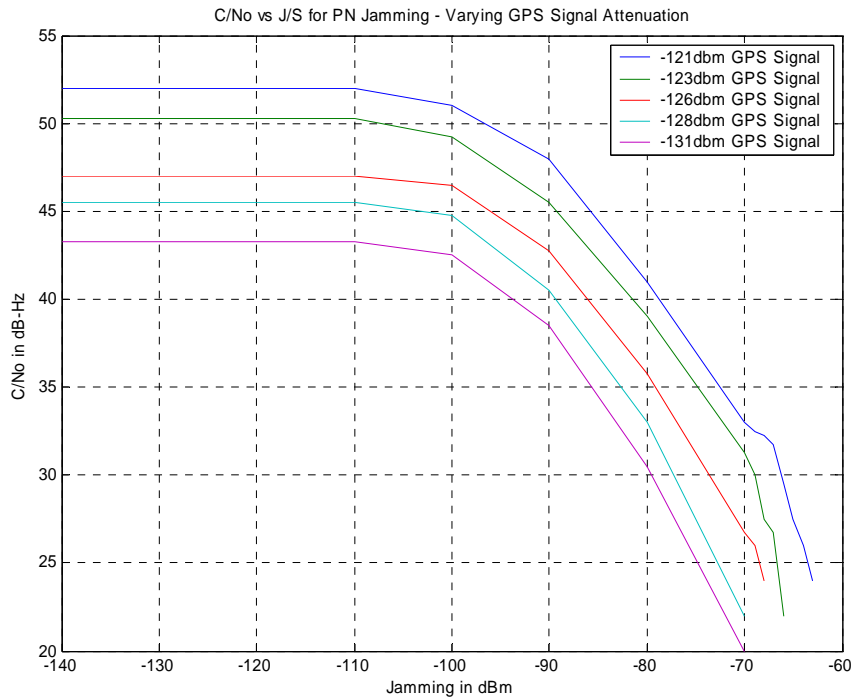

Figure 31 C/N₀ vs. 1 MHz PN Jamming

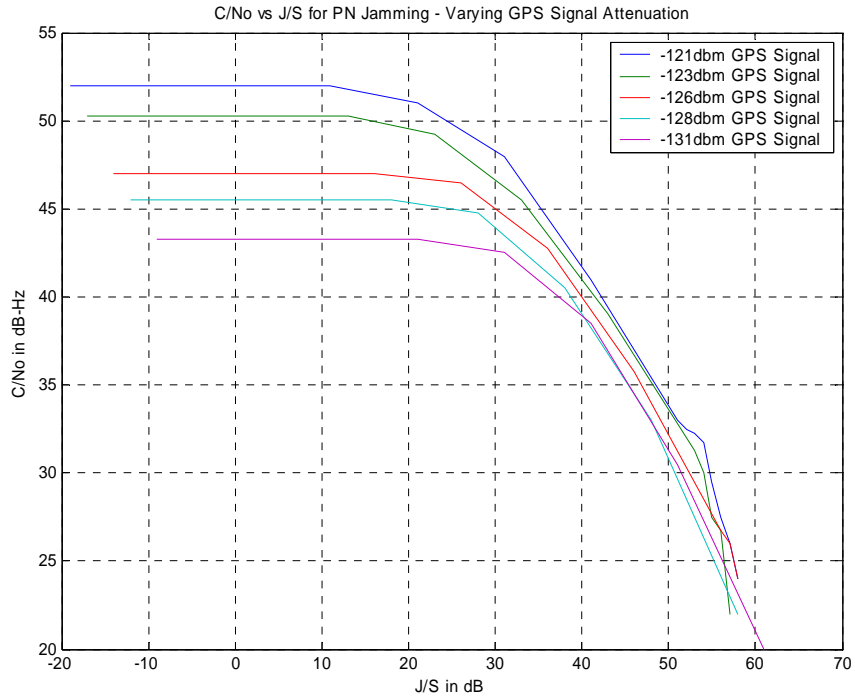

Figure 32 C/N₀ vs. J/S for 1 MHz PN Jamming

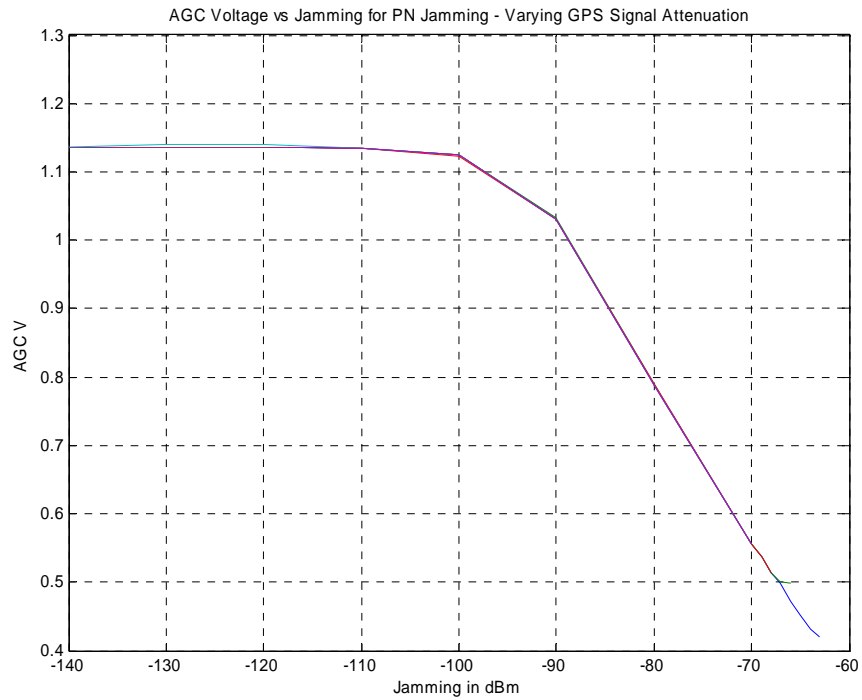

Figure 33 AGC vs. 1 MHz PN Jamming

9 Chirp Jamming

This series of tests uses the Noise Com generator's "chirp" jamming mode. The jammer is a CW carrier with rapidly varying frequency. The jamming frequency is varied from 1565.42MHz to 1585.42MHz (+/- 10MHz about L1) every 0.5ms. Thus, the jammer sweeps across its entire frequency range twice per receiver I and Q integration period. The sweep range was chosen so that it crosses many C/A spectral lines.

The test setup is as shown in Figure 34. The jamming strength is adjusted by varying the attenuator settings. The satellite signal strength is constant during the run, but can be varied between runs by adjusting the attenuator settings.

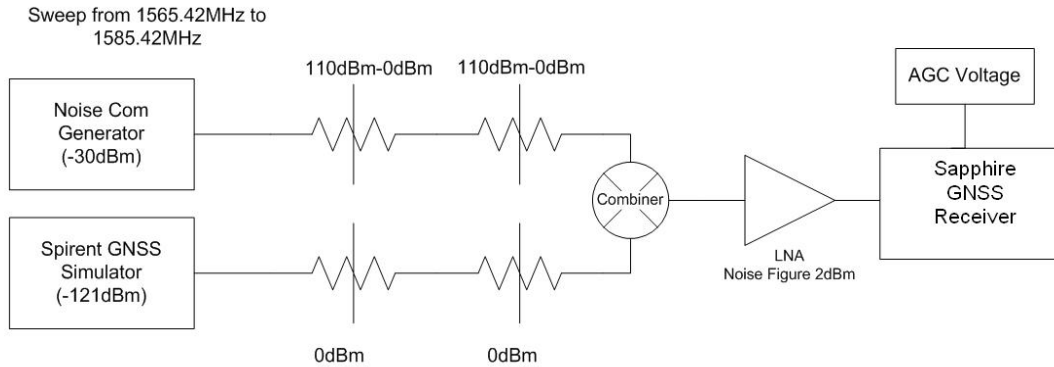

Figure 34 Chirp Jamming Test Setup

Receiver performance in the presence of the chirp jamming is nearly identical to CW jamming tests, Figure 35. No spectral line effects were observed. The observed performance is consistent with expectations. Due to the rapid rate of frequency change, spectral line correlation is present for a small fraction of the I, Q integration time, so there is essentially no degradation.

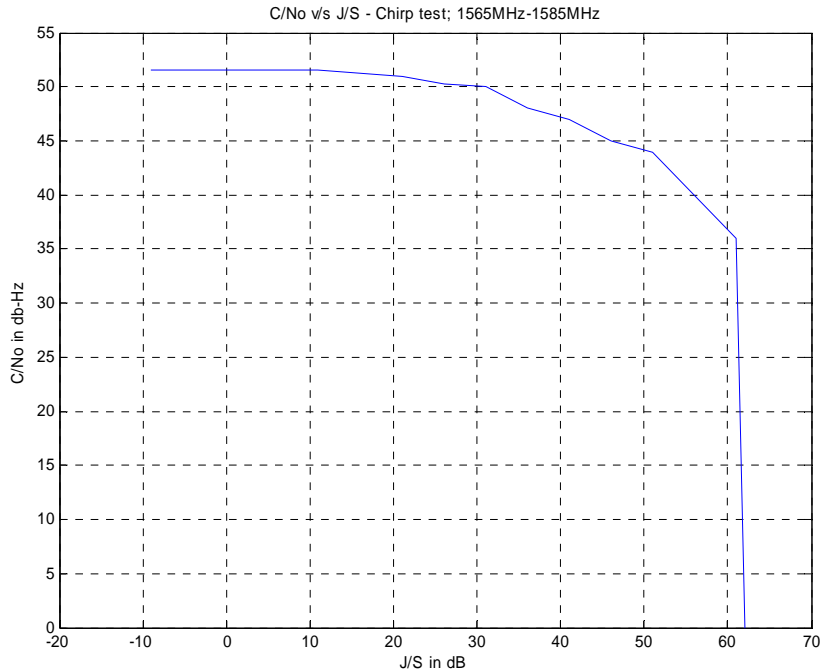

Figure 35 C/N₀ vs. J/S for Chirp Jamming

10 Pulsed Broadband Jamming

In this series of tests the Noise Com generator is set to simulate 10 MHz wide broadband noise, which has a 10 percent duty cycle and a cycle period 1 ms. The center frequency is set at 1575.42 MHz. The strength of the jamming signal and the strength of the GPS signal are varied by adjusting the attenuators (Figure 36). (Note: the Noise Com generator takes an entire day to configure itself for this type of test. Since, as expected, the test results match those for the pulse jamming; only the 10 percent duty cycle test was created and run.)

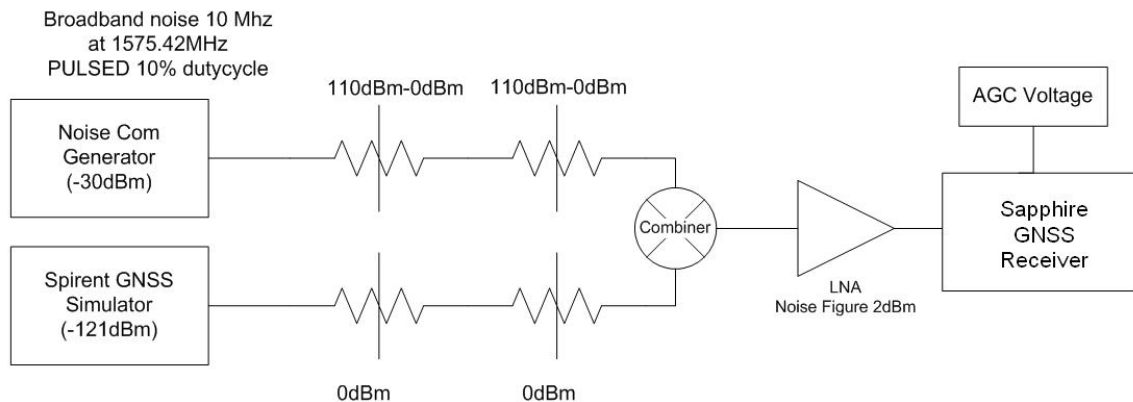

Figure 36 Pulsed Broadband Jamming Test Setup

The results from these tests duplicate the results from the pulse-jamming tests. The pulse detection and blanking hardware accurately identifies and blanks the jamming pulses for

continuous error free operation. The receiver did not loose lock at any jamming level (that could be produced by the test equipment) due to the 10 percent duty cycle.

11 Broadband Jamming

In this series of tests, the Noise Com generator is set to simulate broadband noise with bandwidth of 30 MHz, 10 MHz or 1 MHz. The center frequency of the jamming is set at 1575.42 MHz. The jamming power is adjusted with the attenuators. During the tests the power of the GPS signal is held constant.

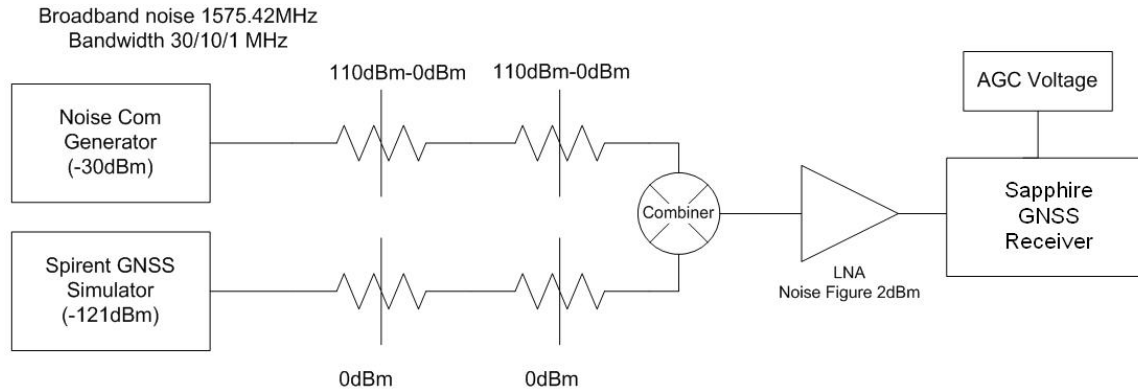

Figure 37 Broadband Jamming Test Setup

Very similar jamming resistance is observed for each of the three broadband noise bandwidths. The receiver loses lock when J/S is 53 to 55 dB. We anticipated that broadband jamming should look like additional thermal noise to the receiver. We anticipate J/S of about 50 dB for 30 MHz, 45 dB for 10 MHz and 35 dB for 1 MHz. The enhanced anti-jamming performance probably means the Noise Com generator is generating FM modulated noise instead of Gaussian noise. The root cause of the difference was not investigated further because of lack of time and because the results are better than expected.

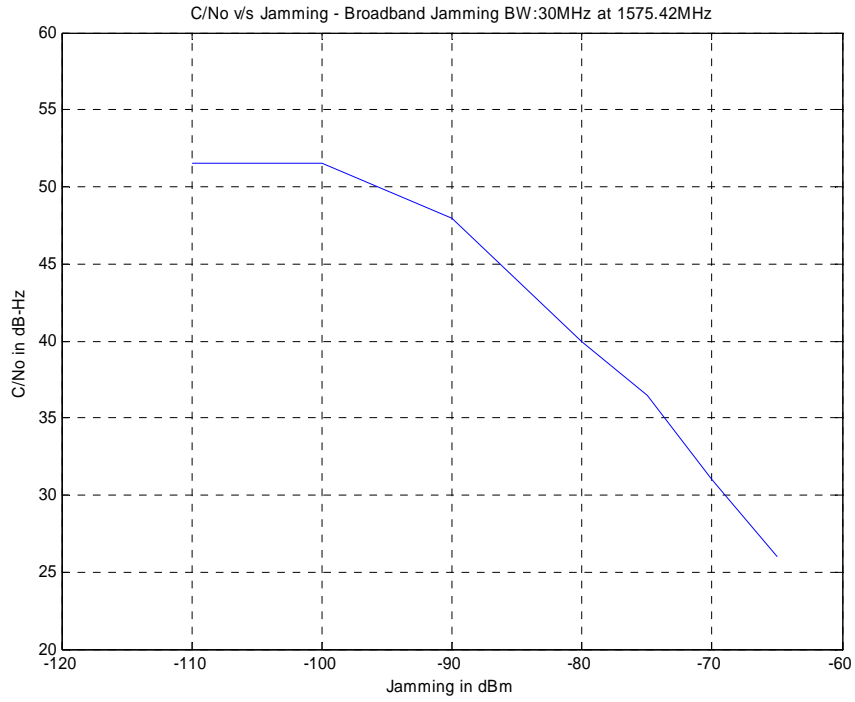

Figure 38 C/N₀ vs. 30 MHz Broadband Jamming

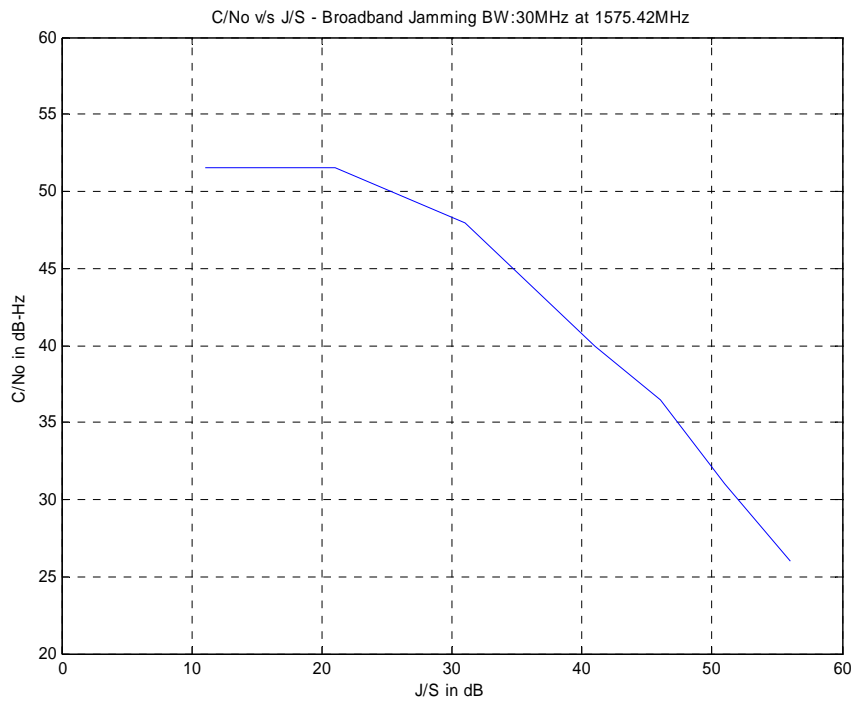

Figure 39 C/N₀ vs. J/S for 30 MHz Broadband Jamming

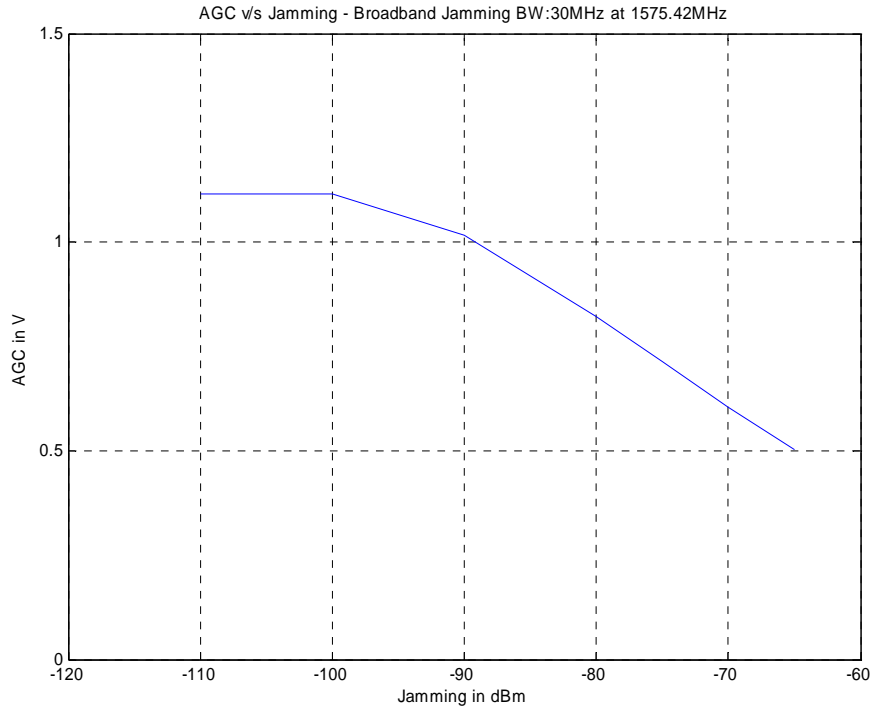

Figure 40 AGC vs. J/S for 30 MHz Broadband Jamming

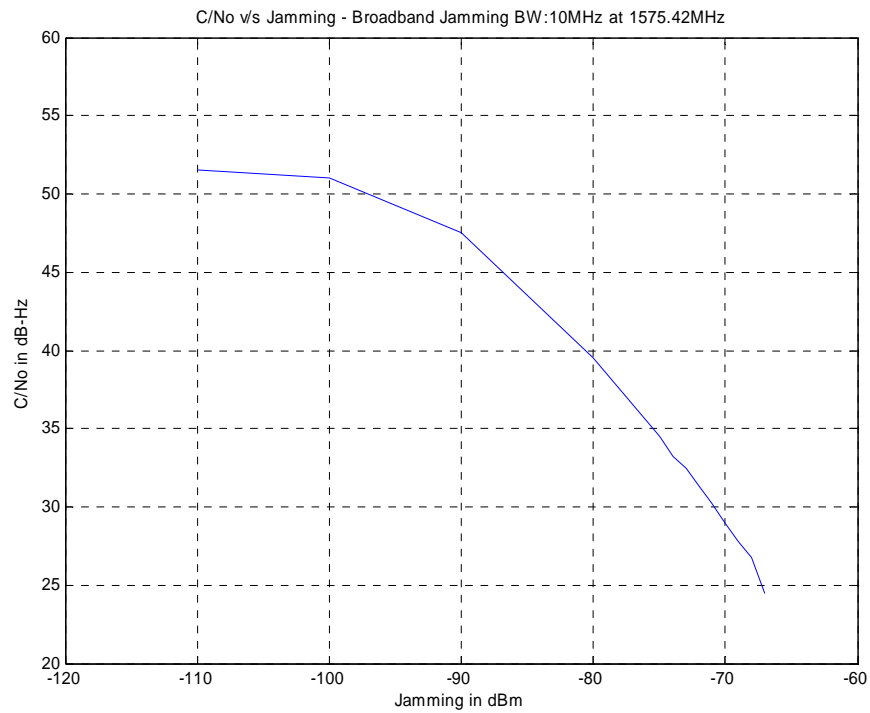

Figure 41 C/N₀ vs. 10 MHz Broadband Jamming

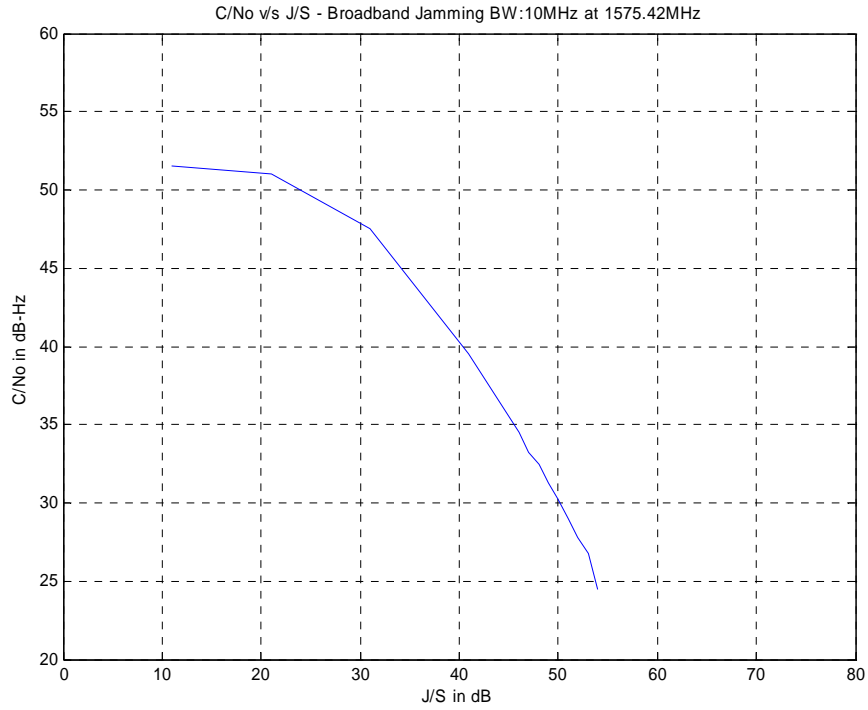

Figure 42 C/N₀ vs. J/S for 10 MHz Broadband Jamming

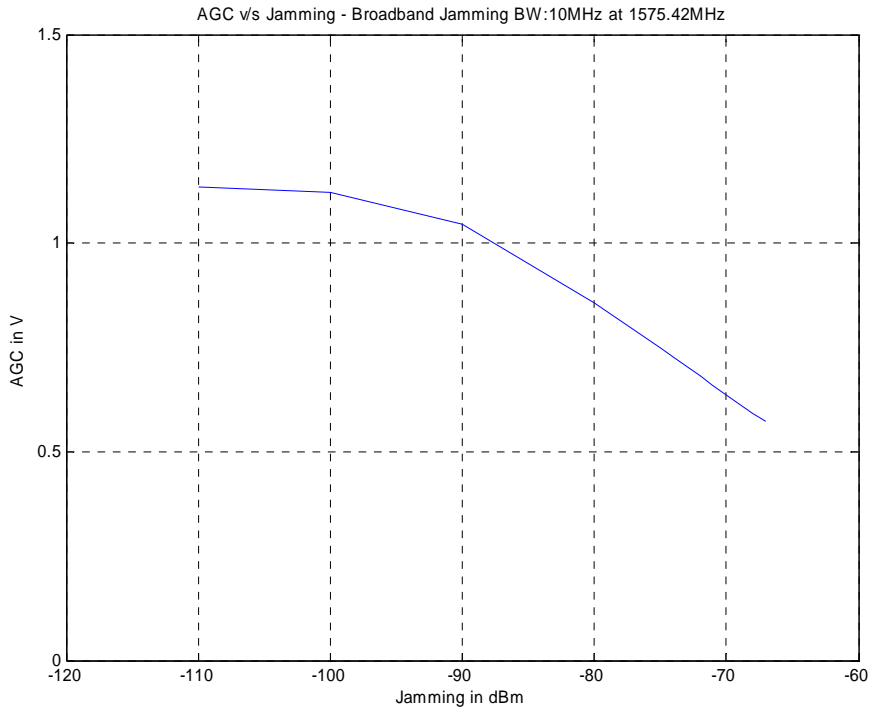

Figure 43 AGC vs. Jamming - For 10 MHz Broadband Jamming

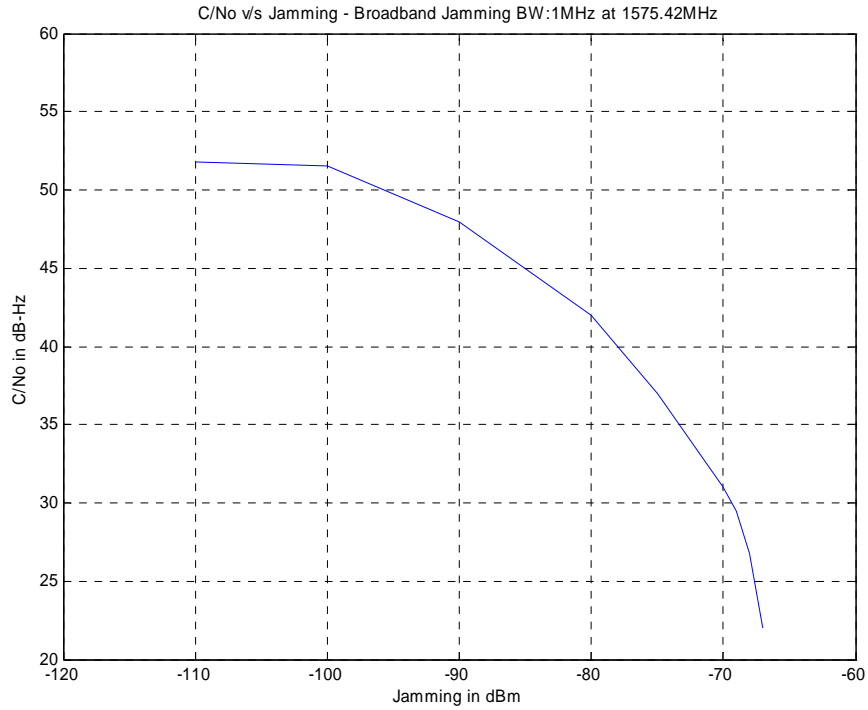

Figure 44 C/N_0 vs. 1 MHz Broadband Jamming

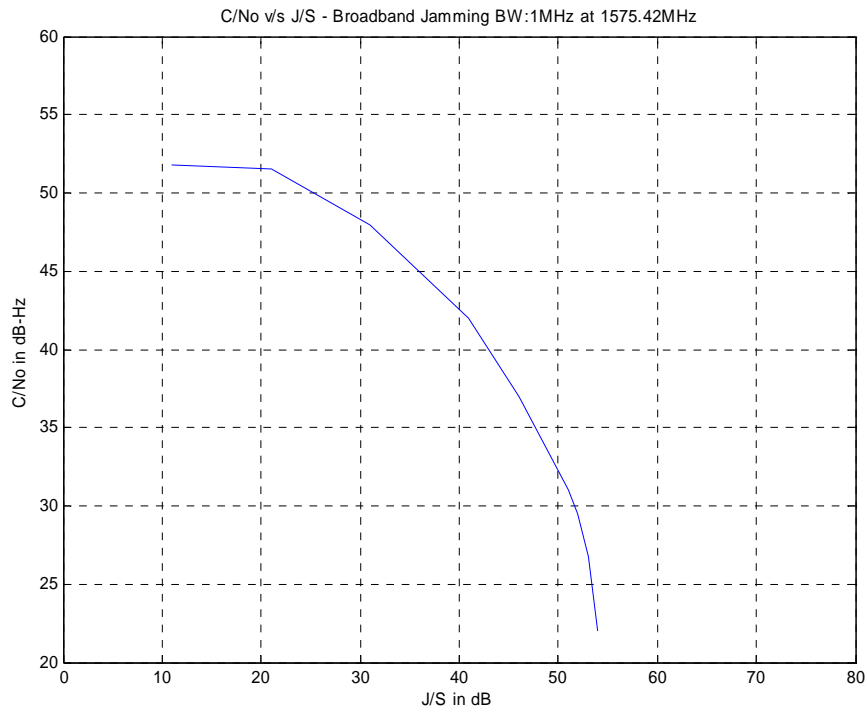

Figure 45 C/N_0 vs. J/S – For 1 MHz Broadband Jamming

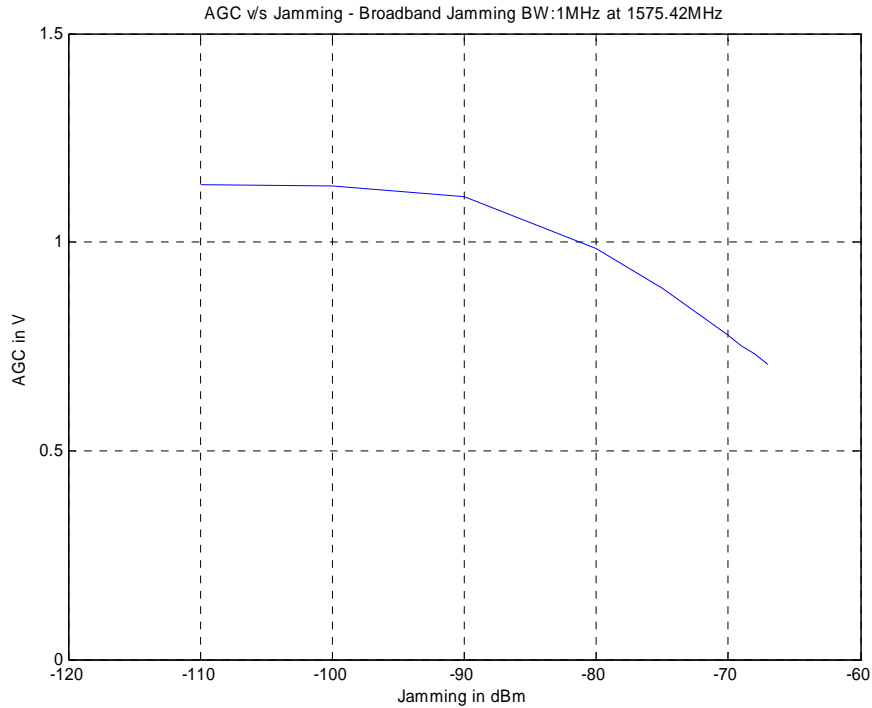

Figure 46 AGC vs. Jamming - For 1 MHz Broadband Jamming

12 Frequency sweep – L1 + Doppler offset

The HP signal generator is used to create a CW signal sweep. The frequency sweep is approximately equal to the sum of L1 frequency (i.e., 1575.42 MHz) and the reference oscillator frequency offset at L1 (i.e., 61400 Hz). The satellite is set to almost zero Doppler (geostationary). This jamming frequency is chosen because it will have zero frequency after the receiver's NCO phase rotations and will be a constant signal to the I and Q accumulators. This is anticipated design weakness of the receiver and anti-jamming system.

The characteristics of the frequency sweep of the jamming signal are:

Frequency sweep center: $f_c + f_o = 1575.42 \text{ MHz} + 61400 \text{ Hz} = 1575.481400 \text{ MHz}$

Frequency sweep start: $f_{s_start} = 1575.481400 \text{ MHz} - 25000 \text{ Hz} = 1575.456400 \text{ MHz}$

Frequency sweep stop: $f_{s_stop} = 1575.481400 \text{ MHz} + 25000 \text{ Hz} = 1575.506400 \text{ MHz}$

Due to the large amount of data being logged (i.e., over seven hours for each run), the results here only portray the area of interest where a loss of lock was observed. Please note that the x-axis which indicates time does not display the time into the run accurately, but is merely a reference of how long the receiver lost lock.

The test setup is shown in Figure 47. The HP signal generator is configured to slowly vary its frequency from 1575.4564 MHz to 1575.5064 MHz in 10 Hz steps, 5 seconds per step. The signal strength the satellite is set to -121 dBm for all tests. The strength of the jamming signal is varied between runs by adjusting the attenuators.

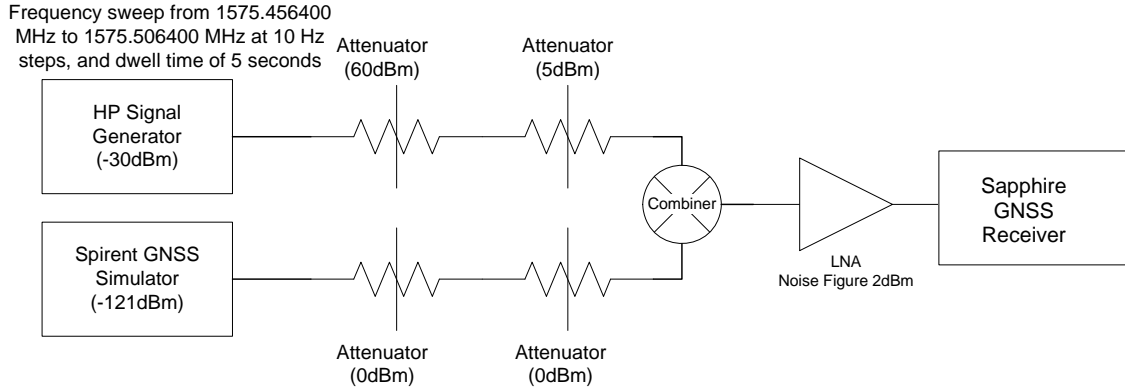

Figure 47 Test setup for frequency sweep Doppler equal reference oscillator offset

The receiver’s jamming resistance for this frequency of CW jamming signal is 26 dB (J/S) compared to nearly 60 dB J/S for a typical CW signal and 30 dB J/S for a C/A code spectral line (Table 4). Details of the runs are shown in Figure 48, Figure 49 and Figure 50.

Jamming Strength (dBm) (HP signal Generator internal = -30dBm)	J/S in dB	Status
-65 + (-30) = -95	-95 - (-121) = 26	LOCK
-64 + (-30) = -94	-94 - (-121) = 27	Loss of LOCK
-55 + (-30) = -85	-85 - (-121) = 36	Loss of LOCK

Table 4 Frequency sweep at center frequency + Doppler offset

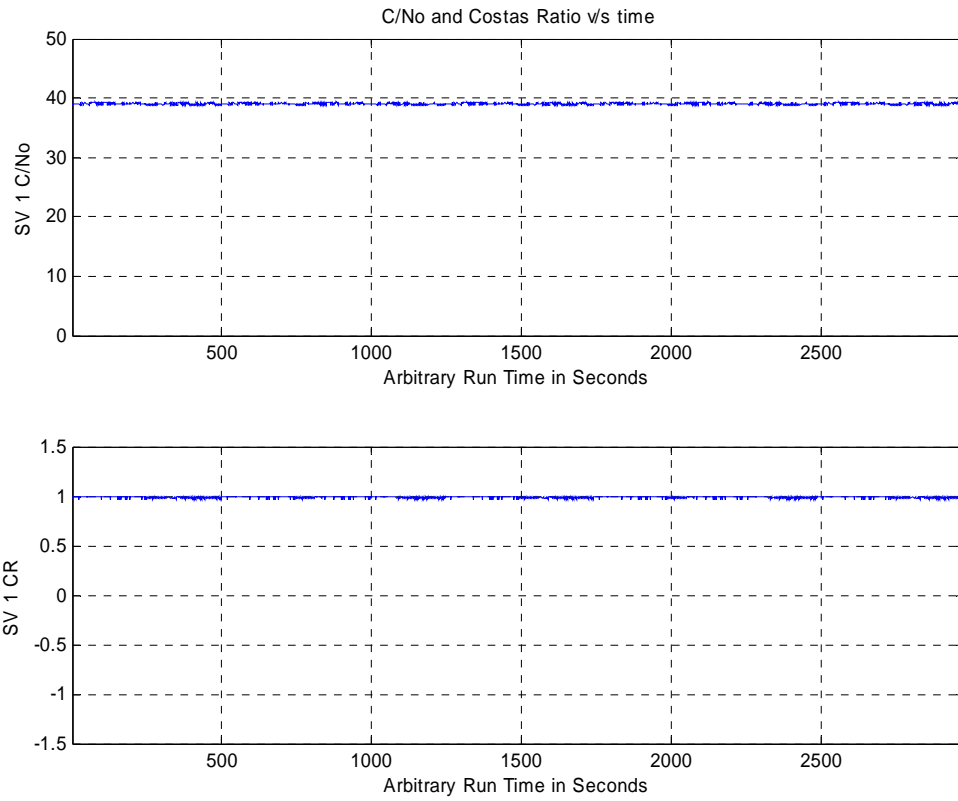

Figure 48 C/No and Costas Ratio vs. time for J/S = 26 dB

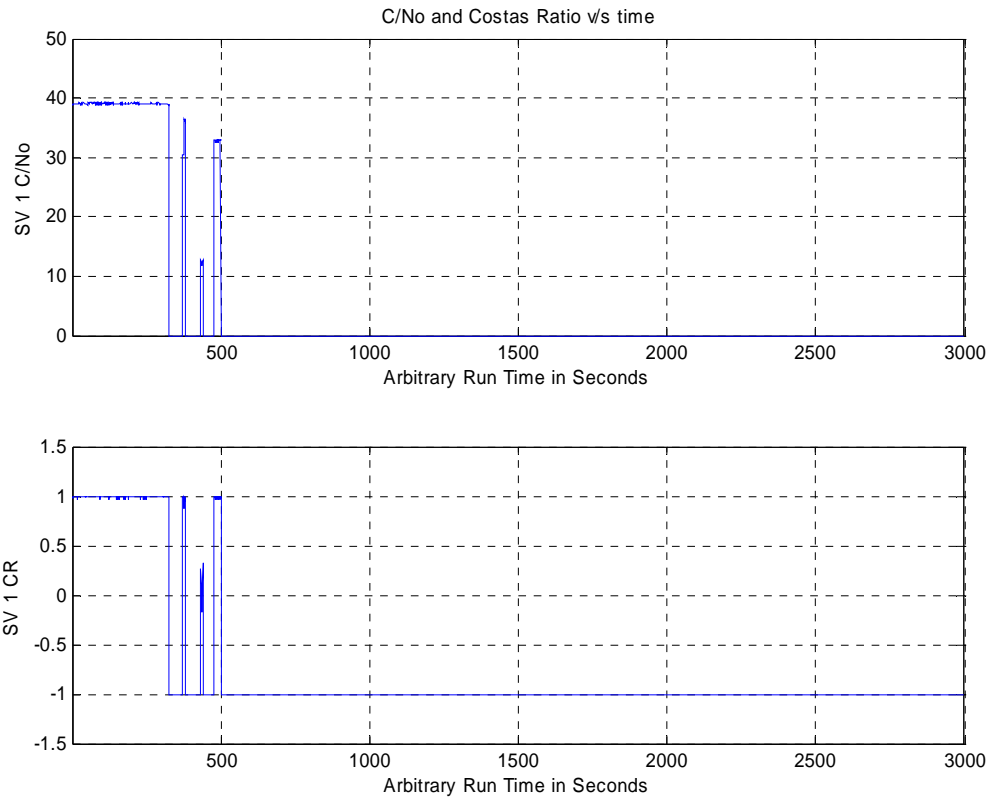

Figure 49 C/No and Costas ratio vs. time for J/S = 27 dB

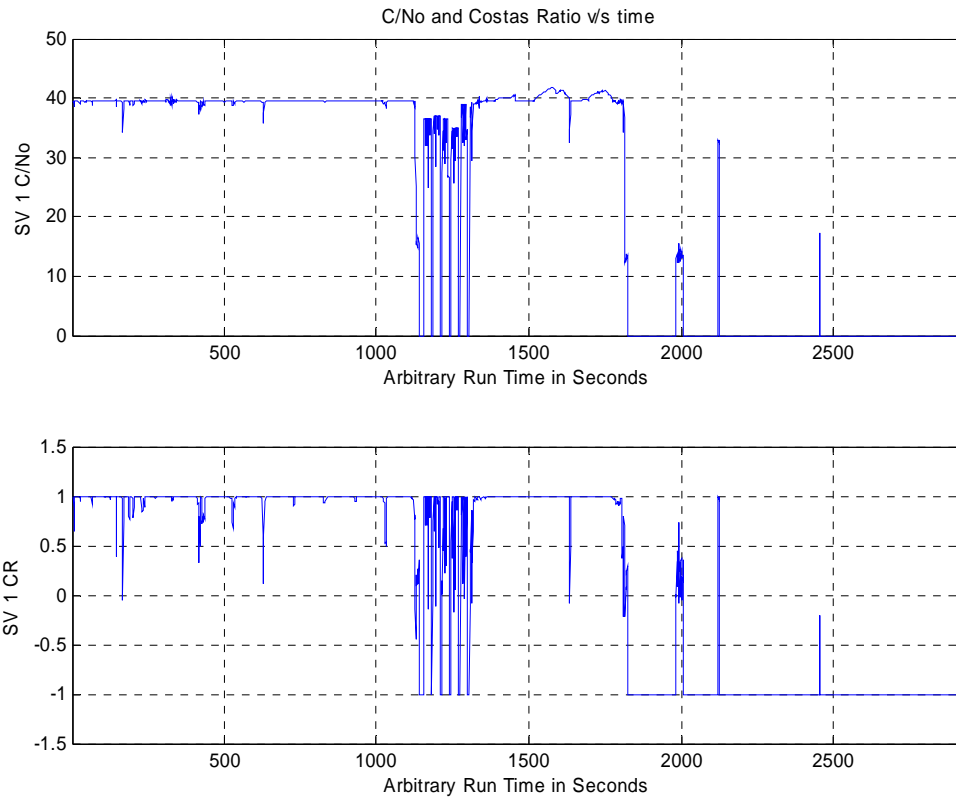

Figure 50 C/No and Costas ratio vs. time for J/S = 36 dB

13 Frequency sweep – L1 + 0.5 * Doppler offset

The test setup is identical to the previous test, except the frequency of the jamming signal is set to sweep across 0.5 time the reference oscillator offset at L1 (approximately 30700 Hz). The HP signal generator is used to create a CW signal sweep. The frequency sweep is approximated to the sum of L1 frequency (i.e., 1575.42 MHz) and half of the nominal clock offset for L1 (i.e., $61400/2 = 30700$ Hz). The satellite is set near zero Doppler (geostationary). The characteristics of the frequency sweeps are:

Frequency sweep center: $f_c + f_o = 1575.42 \text{ MHz} + 30700 \text{ Hz} = 1575.450700 \text{ MHz}$
 Frequency sweep start: $f_{s_start} = 1575.450700 \text{ MHz} - 25000 \text{ Hz} = 1575.425700 \text{ MHz}$
 Frequency sweep stop: $f_{s_stop} = 1575.450700 \text{ MHz} + 25000 \text{ Hz} = 1575.475700 \text{ MHz}$
 The sweep is performed at 10 Hz steps and a dwell time of 5 seconds at each step.

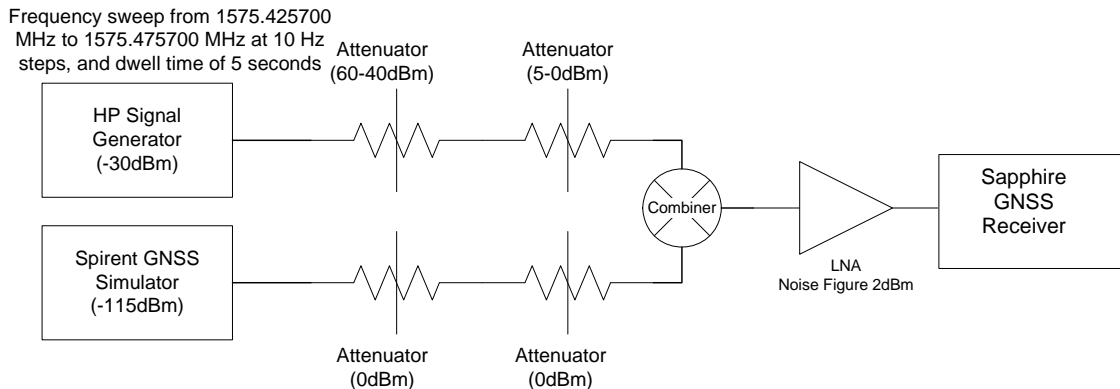

Figure 51 Test setup for frequency sweep

Due to the large amount of data being logged (over seven hours), the results here only portray the area of interest (where a loss of lock was observed). Please note that the x-axis which indicates time does not display the time into the run accurately, but is merely a reference of how long the receiver lost lock.

The results of these tests are summarized in Table 5. The receiver lost lock at J/S of 31 dB compared to 26 dB when the jamming frequency was equal to the oscillator offset.

Jamming Strength (dBm) (HP signal Generator internal = -30dBm)	J/S in dB	Status
$-65 + (-30) = -95$	$-95 - (-121) = 26$	LOCK
$-60 + (-30) = -90$	$-90 - (-121) = 31$	LOCK
$-59 + (-30) = -89$	$-89 - (-121) = 32$	Loss of LOCK
$-55 + (-30) = -85$	$-85 - (-121) = 36$	Loss of LOCK

Table 5 Frequency sweep at center frequency + 0.5*Doppler offset

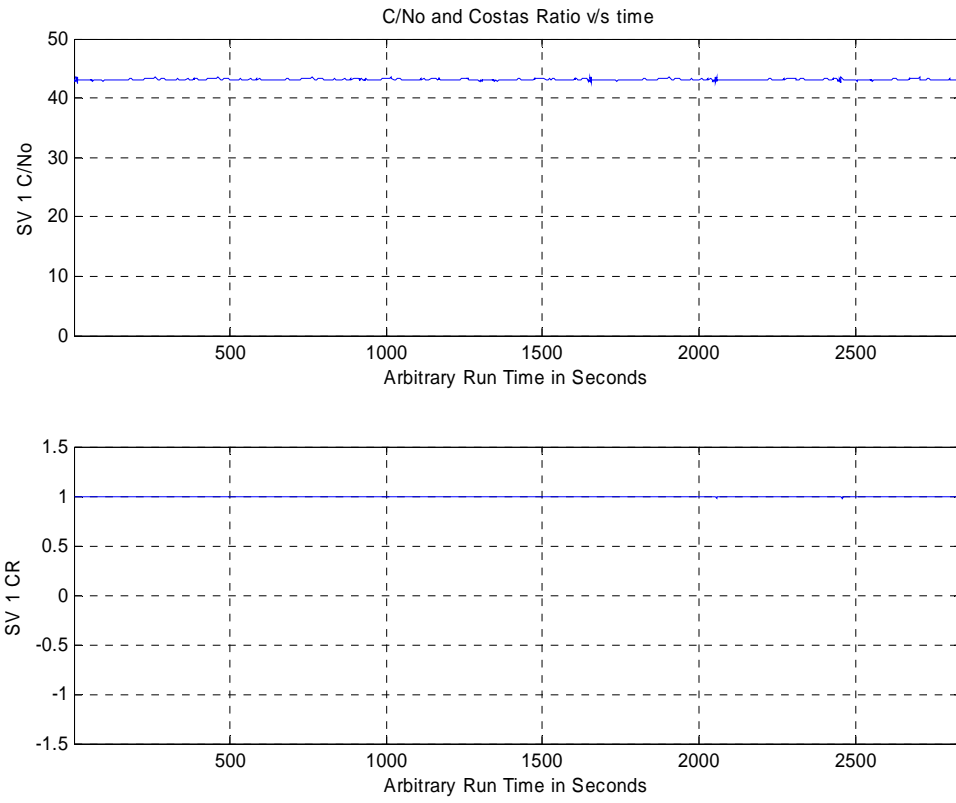

Figure 52 C/No and Costas ratio vs. time for 26 dB J/S

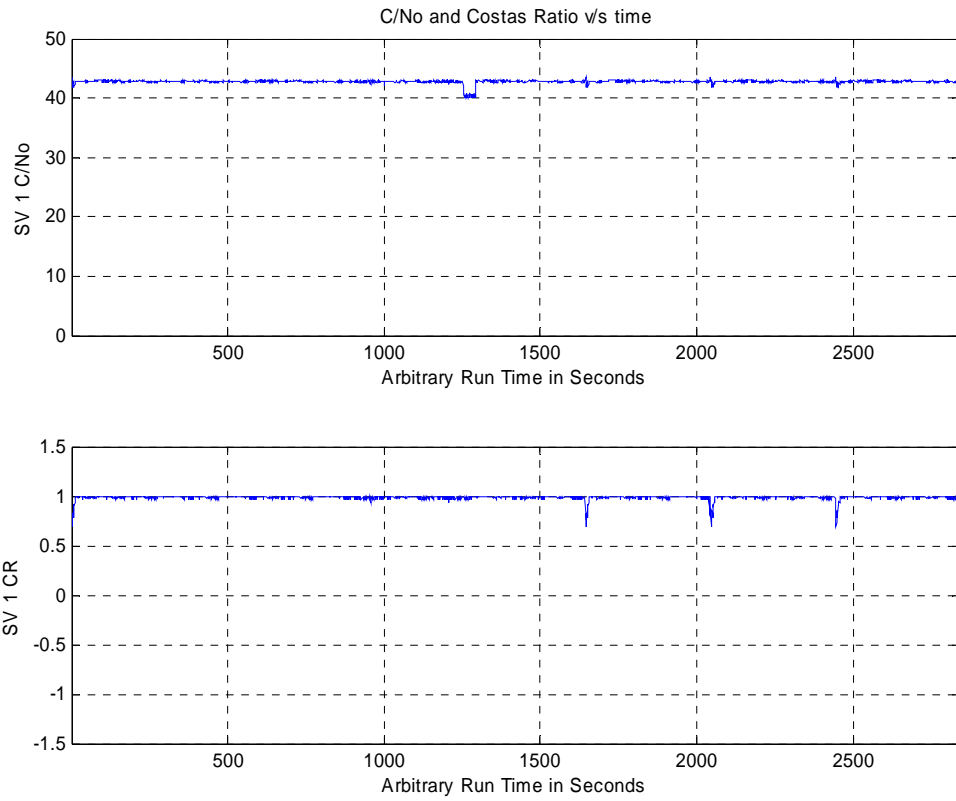

Figure 53 C/No and Costas ratio vs. time for 31 dB J/S

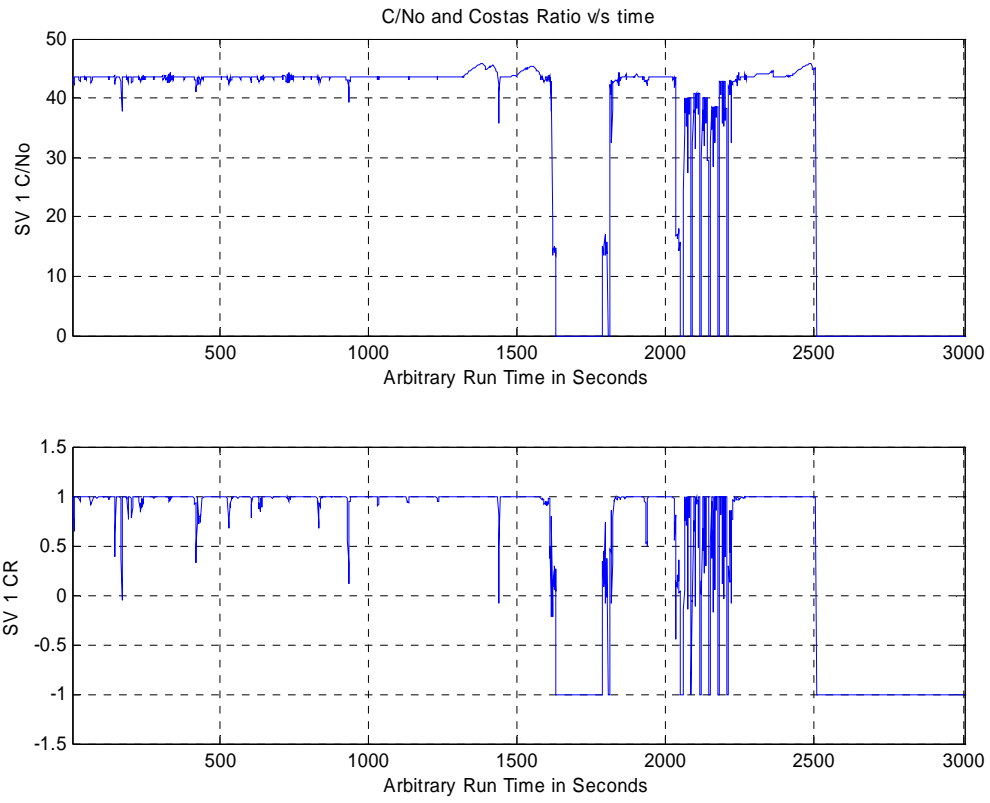

Figure 54 C/No and Costas ratio vs. time for 32 dB J/S

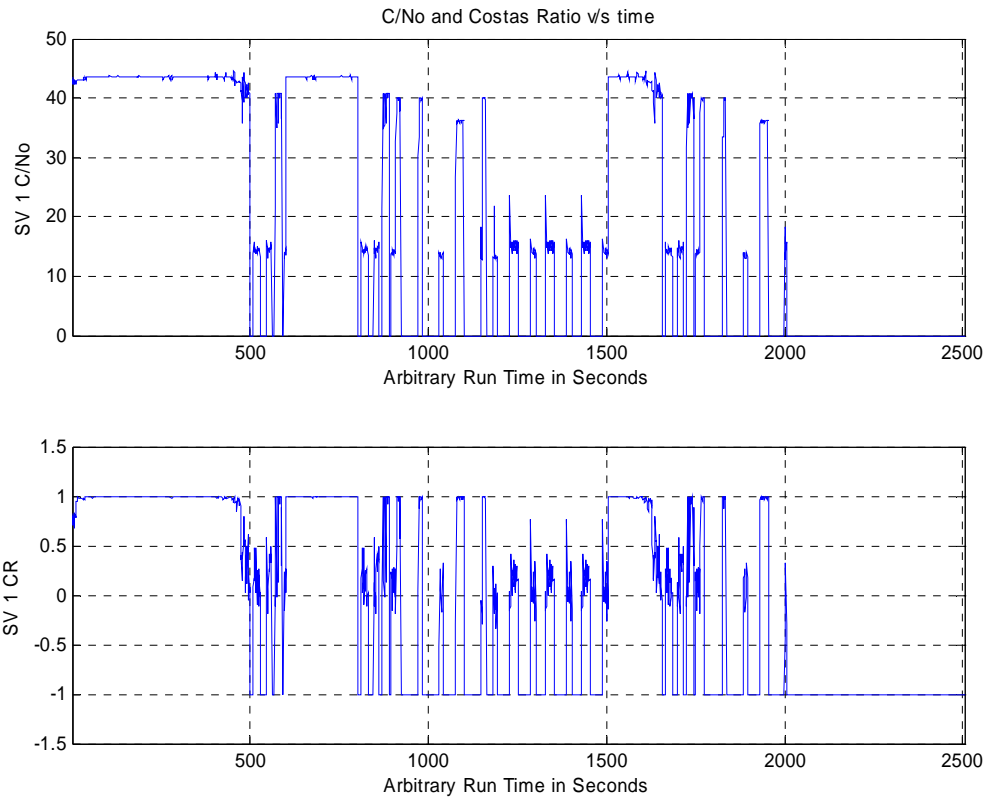

Figure 55 C/No and Costas ratio vs. time for 36 dB J/S