

FILTER OVERVIEW WITH SERVICE INTERVALS AND CAPACITIES

6M iT4 Series Tractors - 6105M, 6115M, 6125M, 6140M, 6150M and 6170M

ENGINE

OPEN CRANKCASE VENTILATION (OCV) FILTER –
[DZ105100](#) (6140M, 6150M, 6170M)

[DZ105796](#) (6105M, 6115M, 6125M)

Replace after every 1500 hours or 2 years, whichever occurs first.

ENGINE

SECONDARY AIR FILTER – [AL215054](#)

Replace at every fourth change of Primary Air Filter, or after 4500 hours or 5 years, whichever occurs first.

ENGINE

PRIMARY AIR FILTER –

[AL215055](#) (6105M, 6115M, 6125M)

[AL215053](#) (6140M, 6150M, 6170M)

Replace after every 1500 hours or 2 years, whichever occurs first. Change Cab Air Filters as well.

TRANSMISSION

OIL FILTER – [AL221066](#)

Replace after first 100 hours, then after first 750 hours and every 750 hours thereafter. Change Hydraulic Oil Filter as well.

HYDRAULICS

FILTER ELEMENT – [AL169573](#)

Replace after first 100 hours, then after first 750 hours and every 750 hours thereafter. Change Transmission Oil Filter as well.

(Click here for [capacity](#))

ENGINE

OIL FILTER –

[RE504836](#) (6105M, 6115M, 6125M, 6140M)

[RE539279](#) (6150M, 6170M)

Replace after first 100 hours, then after first 500 hours and every 500 hours thereafter or annually, whichever occurs first.

The extended 500 hour interval is only allowed if using Plus-50™ II oil, JD OEM Oil Filter and diesel fuel with sulfur content less than 15mg/kg (15 ppm).

Change Oil and Filter after every 250 hours, if conditions are not met.

(Click here for [capacity](#))

June 2019. Subject to change without notice.

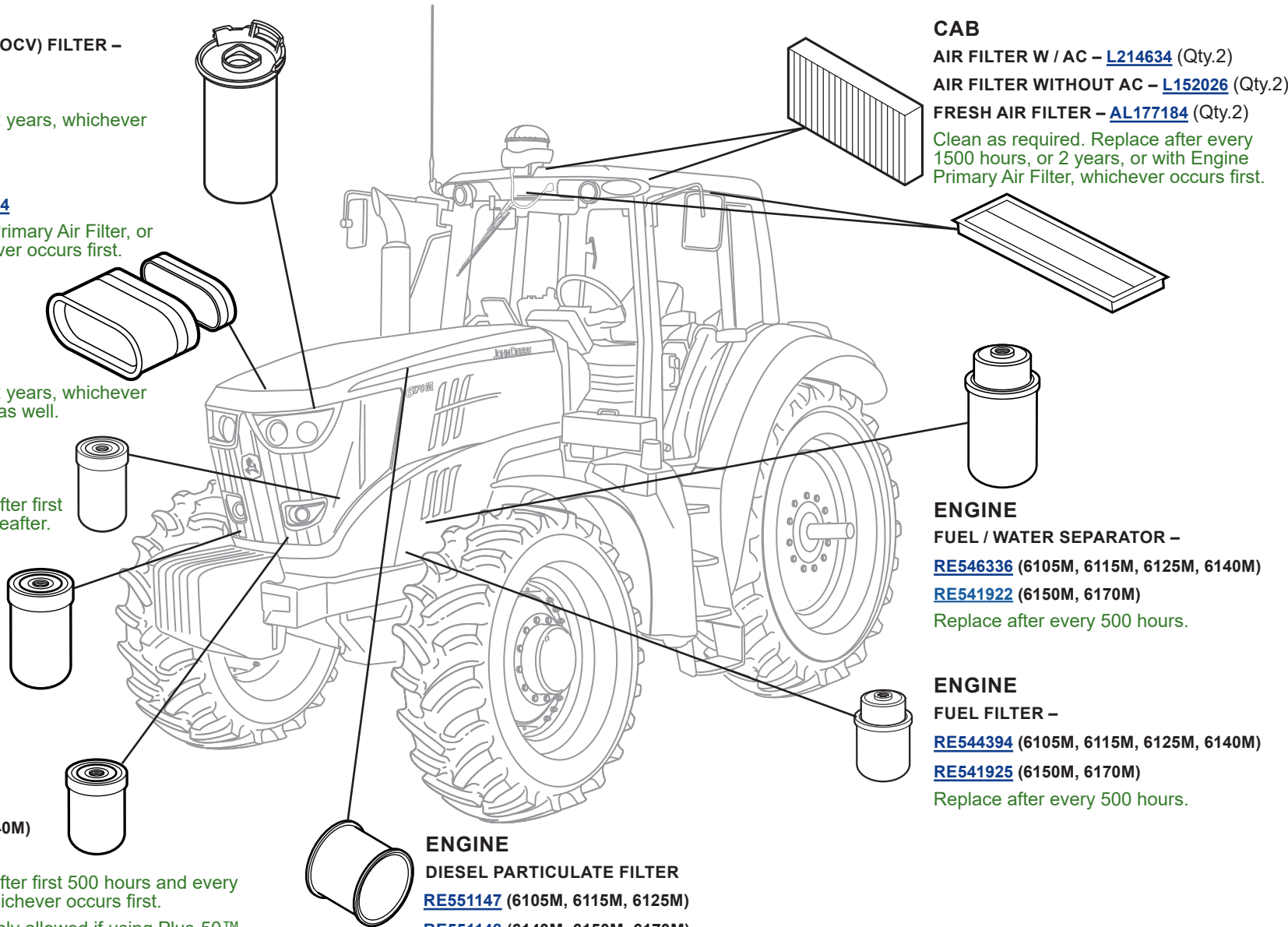

CAB

AIR FILTER W / AC – [L214634](#) (Qty.2)

AIR FILTER WITHOUT AC – [L152026](#) (Qty.2)

FRESH AIR FILTER – [AL177184](#) (Qty.2)

Clean as required. Replace after every 1500 hours, or 2 years, or with Engine Primary Air Filter, whichever occurs first.

ENGINE

FUEL / WATER SEPARATOR –

[RE546336](#) (6105M, 6115M, 6125M, 6140M)

[RE541922](#) (6150M, 6170M)

Replace after every 500 hours.

ENGINE

FUEL FILTER –

[RE544394](#) (6105M, 6115M, 6125M, 6140M)

[RE541925](#) (6150M, 6170M)

Replace after every 500 hours.

ENGINE

DIESEL PARTICULATE FILTER

[RE551147](#) (6105M, 6115M, 6125M)

[RE551148](#) (6140M, 6150M, 6170M)

Replace within 250 hours after exhaust filter and warning light indicators are alerted on display.



JOHN DEERE

Genuine Parts and Service

https://www.deere.com/en_US/parts/parts_by_industry/ag/fmi/filter_maintenance_information.page

CAPACITIES

6M iT4 Series Tractors - 6105M, 6115M, 6125M, 6140M, 6150M and 6170M

CAPACITIES (Approximate):

Fuel Tank:

6105M, 6115M, 6125M.....	220 L (58.1 gal)
6140M.....	290 L (76.6 gal)
6150M.....	300 L (79.2 gal)
6170M.....	355 L (93.8 gal)

Cooling System:

Cool-Gard™ II

.....	28.2 L (7.5 gal)
-------	------------------

Crankcase including Filter:

Plus-50™ II

6105M, 6115M, 6125M, 6140M.....	16 L (4.2 gal)
6150M, 6170M.....	23.5 L (6.2 gal)

Transmission Case:

Hy-Gard™

6105M, 6115M, 6125M, 6140M.....	52 L (13.7 gal)
6150M, 6170M.....	56 L (14.8 gal)
Extra with creeper.....	1 L (0.3 gal)
Extra with additional oil reservoir.....	14 L (3.7 gal)
Extra with front-wheel drive axle.....	3 L (0.8 gal)
With Front PTO.....	2.6 L (0.69 gal)

Front-wheel Drive:

Hy-Gard™

Axle housing.....	8.2 L (2.2 gal)
Final drives (without brake).....	1.7 L (0.4 gal)
Final drives (with brake).....	2.6 L (0.7 gal)

Air-conditioning System:

R134a Refrigerant.....	1225 - 1275 g (2.70 - 2.81 lb)
Oil Volume (PAG oil).....	220 ml (7.44 fl oz)

[Return to Filter Overview](#)

