

FILTER OVERVIEW WITH SERVICE INTERVALS AND CAPACITIES

5105 and 5205 Series Tractors

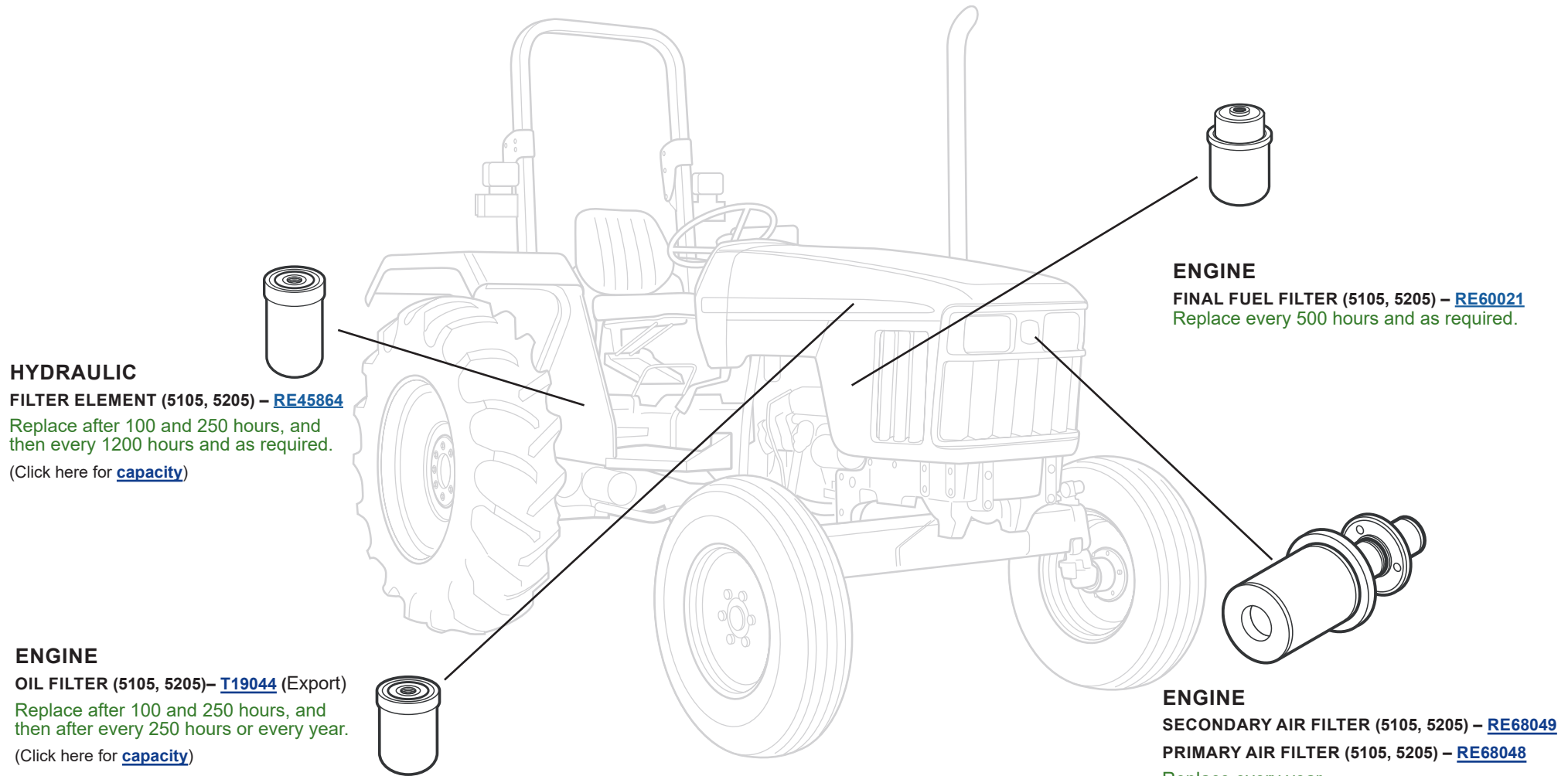

CAPACITIES

5105 and 5205 Series Tractors

CAPACITIES (Approximate):

Fuel Tank:

5105 and 5205 Series Tractors 84.8 L (22.4 gal)

Crankcase including Filter Change:

5105 and 5205 Series Tractors 7.5 L (1.98 gal)

Cooling System:

5105 and 5205 Series Tractors 9.5 L (2.5 gal)

SyncReverser™ Transmission:

Grease Axle 32 L (8.4 gal)

Oil Axle 32 L (8.4 gal)

Mechanical Front Wheel Drive (MFWD) - If Equipped:

Wheel Hubs (Each) 0.7 L (0.18 gal)

Axle Housing 4.5 L (1.19 gal)

[Return to Filter Overview](#)

