

# FILTER OVERVIEW WITH SERVICE INTERVALS AND CAPACITIES

## 4700/4710 Self-Propelled Sprayers

### CAB

#### AIR FILTER

ACTIVATED CARBON – [RE199681](#)

Replace after every 500 hours or annually, whichever occurs first and as required.

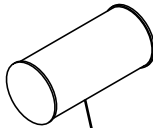

### ENGINE

PRIMARY AIR FILTER – [RE65880](#)

Clean or replace as required.

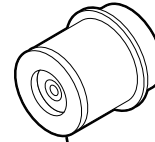

### ENGINE

SECONDARY AIR FILTER – [RE34967](#)

Replace as required.

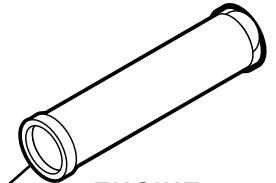

### ENGINE

OIL FILTER – [RE59754](#)

Replace after 50 hours and then after every 200 hours. If Plus-50™ engine oil and a John Deere™ filter are used, the oil and filter service interval may be extended 50 percent, up to 300 hours.



(Click here for [capacity](#))



### ENGINE

FUEL FILTER – [RE62419](#)

Replace after every 500 hours.

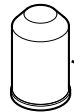

### ON BOARD AIR (OBA)

AIR DRYER CARTRIDGE – [AN204967](#)

Replace annually.

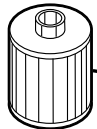

### CAB

#### AIR FILTER RECIRCULATION

ACTIVATED CARBON – [RE199682](#)

Replace after every 500 hours or annually, whichever occurs first and as required.



### HYDRAULICS

HYDROSTATIC DRIVE – [AN203010](#)

Initial change after 50 hours then replace after every 400 hours.

(Click here for [capacity](#))

### HYDRAULICS

OIL FILTER – [AN203010](#)

Initial change after 50 hours then replace after every 400 hours.

(Click here for [capacity](#))



### ENGINE

FUEL FILTER – [AR103220](#)

Replace after every 500 hours.

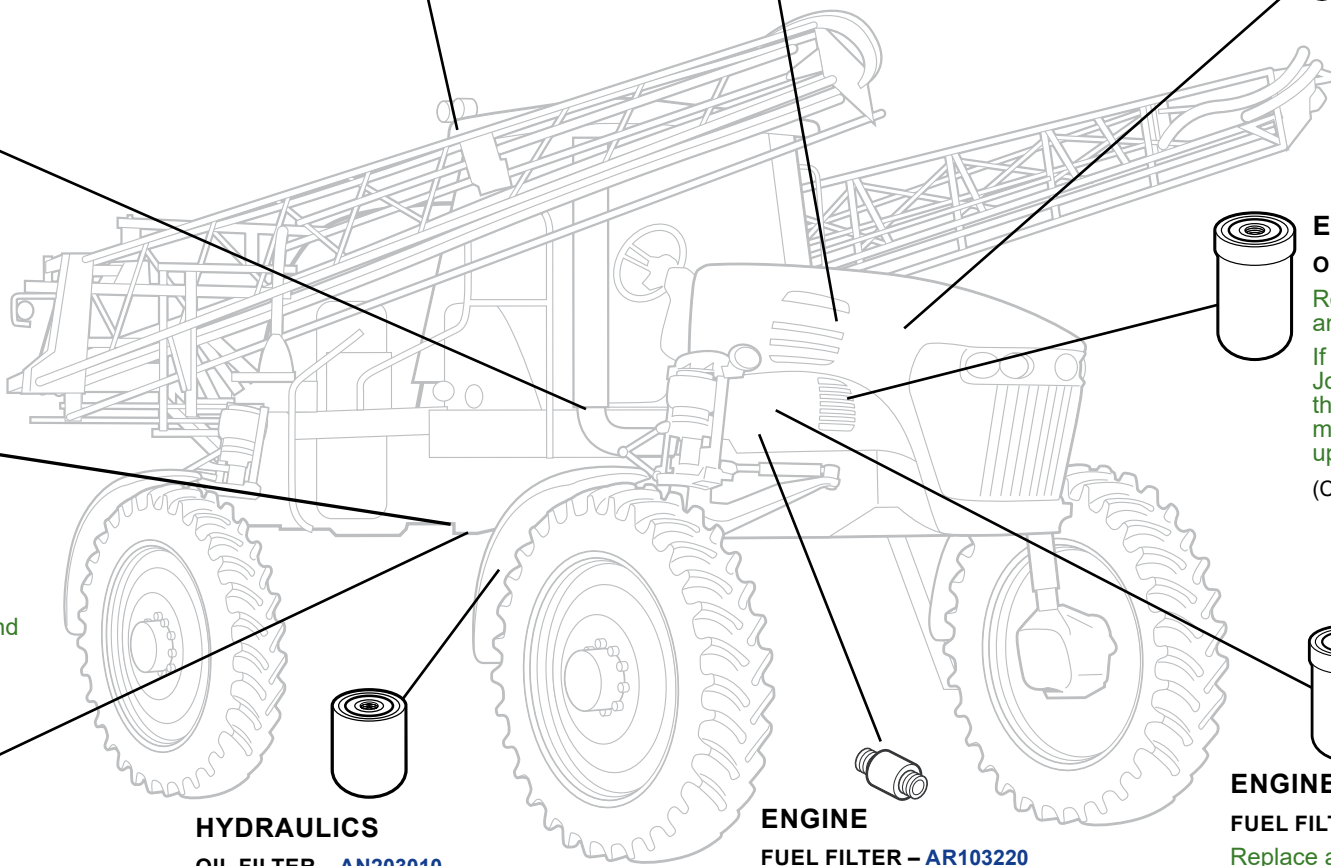

**JOHN DEERE**

Genuine Parts and Service

# CAPACITIES

## 4700/4710 Self-Propelled Sprayers

### CAPACITIES (Approximate):

#### Fuel Tank:

4700.....	321 L (85 gal)
4710.....	360 L (95 gal)

#### Cooling System with Heater:

<b>Cool-Gard™</b> .....	24 L (6.3 gal)
----------------------------	----------------

#### Crankcase including Filter:

<b>Plus-50™</b> .....	20.5 L (5.4 gal)
--------------------------	------------------

#### Hydraulic Reservoir:

<b>Turf-Gard™</b> .....	64 L (17 gal)
----------------------------	---------------

#### Hydraulic System:

<b>Turf-Gard™</b> .....	163 L (43 gal)
----------------------------	----------------

#### Final Drives (Front Hubs) Each:

<b>GL-5</b> 4700.....	917 ml (31 oz)
4710.....	1.2 L (0.32 gal)

#### Final Drives (Rear Hubs) Each:

<b>GL-5</b> 4700.....	1686 ml (57 oz)
4710.....	1.2 L (0.32 gal)

[Return to Filter Overview](#)