

PowerTech™ E

6090HFG84 Diesel Engine

Generator Drive Engine Specifications

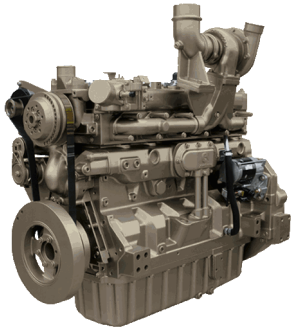

6090HFG84 shown

Engine dimensions

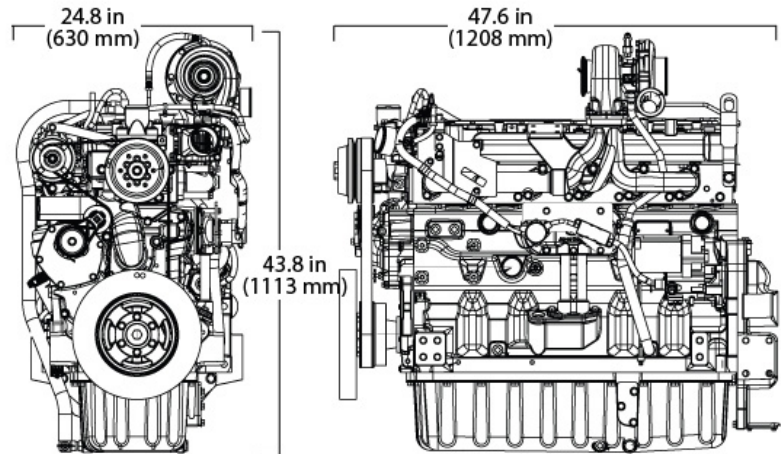

Dimensions may vary according to options selected. Call your distributor for more information.

Certifications

EPA Tier 3
EU Stage III A

General data

Model	6090HFG84	Length - mm (in) to rear of block	1208 (47.6)
Number of cylinders	6	Width - mm (in)	630 (24.8)
Displacement - L (cu in)	9.0 (549)	Height-- mm (in)	1113 (43.8)
Bore and Stroke-- mm (in)	118.4 x 136 (4.66 x 5.35)	Weight, dry-- kg (lb)	901 (1986)
Compression Ratio	16.0 : 1		
Engine Type	In-line, 4-Cycle		
Aspiration	Turbocharged and air-to-air aftercooled		

Performance data range

Rated speed	Engine power				Generator efficiency	Rated fan power		Power factor	Calculated generator set output			
	Prime		Standby			kW	hp		Prime		Standby	
Hz(rpm)	kW	hp	kW	hp	%					kWe*	kVA	kWe
50(1500)	230-277	308-371	253-304	339-408	90-94	17.0	23	0.8	192-244	240-305	213-270	266-337
60(1800)	235-286	315-384	258-315	346-422	90-94	29.4	39	0.8	185-242	232-302	206-268	258-336

Prime power is the nominal power an engine is capable of delivering with a variable load for an unlimited number of hours per year. This rating conforms to ISO3046 and SAE J1995.

Standby power is the maximum engine power available at varying load factors for up to 200 hours per year when applied to conform with ISO 8528-1. This rating conforms to ISO 3046 and SAE J1995. Calculated generator set rating range for standby applications is based on minimum engine power (nominal -5 percent) to provide 100 percent meet-or-exceed performance for assembled standby generator sets.

*Electrical power is calculated from the typical generator efficiency and fan power percentages shown. Applications may vary.

Features and benefits

Fixed Geometry Turbocharger

- Fixed geometry turbochargers are sized for a specific power range and optimized to provide excellent performance across the entire torque curve. They are also designed to maximize fuel economy between the engine's rated speed and peak torque.

High Pressure Common Rail Fuel System and Engine Control Unit (ECU)

- The HPCR fuel system provides variable common rail pressure, multiple injections, and higher injection pressures, up to 1,600 bar (23,000 psi). It also controls fuel injection timing and provides precise control for the start, duration, and end of injection.

4-Valve Cylinder Head

- The 4-valve cylinder head provides excellent airflow with the cross-flow design.

Air-to-Air Aftercooled

- This is the most efficient method of cooling intake air to help reduce engine emissions. It enables an engine to meet emissions regulations with better fuel economy and the lowest installed costs.

Compact Size

- Horsepower/displacement ratio is best-in-class
- Lower installed cost
- Mounting points are the same as previous engine models

John Deere Electronic Engine Controls

- Electronic engine controls monitor critical engine functions, providing warning and/or shutdown to prevent costly engine repairs and eliminate the need for add-on governing components, all lowering total installed costs.

Additional Features

- Self-adjusting poly-vee fan drive
- Forged-steel connecting rods
- Replaceable wet-type cylinder liners
- Either-side service
- Gear driven auxiliary drive