

PowerTech™ Plus 6090HF485 Diesel Engine

Generator Drive Engine Specifications

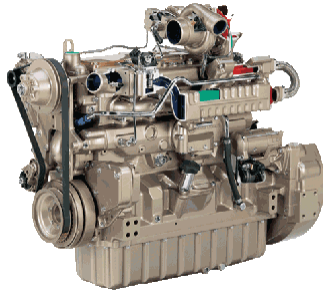

6090HF485 shown

Engine dimensions

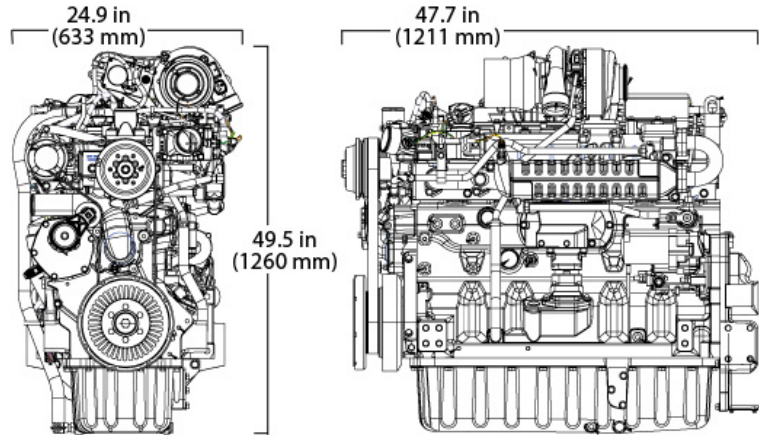

Dimensions may vary according to options selected. Call your distributor for more information.

Emissions

CARB
EPA Tier 3

General data

Model	6090HF485	Length - mm (in) to rear of block	1211 (47.7)
Number of cylinders	6	Width - mm (in)	633 (24.9)
Displacement - L (cu in)	9.0 (549)	Height-- mm (in)	1260 (49.6)
Bore and Stroke-- mm (in)	118.4 x 136 (4.66 x 5.35)	Weight, dry - kg (lb)	1096.8 (2418)
Compression Ratio	16.0 : 1		
Engine Type	In-line, 4-Cycle		
Aspiration	Turbocharged and air-to-air aftercooled		

Performance data range

Rated speed	Engine power				Generator efficiency	Rated fan power		Power factor	Calculated generator set output			
	Prime		Standby			kW	hp		Prime		Standby	
	kW	hp	kW	hp					kWe*	kVA	kWe	kVA
60(1800)	245	328	269	361	90-94	16.1	22	0.8	213-223	267-279	235-245	294-307
50(1500)	193	259	212	285	90-94	12.7	17	0.8	168-176	210-220	185-193	231-242

Prime power is the nominal power an engine is capable of delivering with a variable load for an unlimited number of hours per year. This rating conforms to ISO3046 and SAE J1995.

Standby power is the maximum engine power available at varying load factors for up to 200 hours per year when applied to conform with ISO 8528-1. This rating conforms to ISO 3046 and SAE J1995. Calculated generator set rating range for standby applications is based on minimum engine power (nominal -5 percent) to provide 100 percent meet-or-exceed performance for assembled standby generator sets.

*Electrical power is calculated from the typical generator efficiency and fan power percentages shown. Applications may vary.

Features and Benefits

Jet Fuel Capable

- The John Deere jet fuel capable engines run on military, arctic, and aviation fuel, including Jet A, Jet A-1, JP-5, and JP-8. If you need to switch back to diesel fuel, just fill up the tank and go.

Cooled Exhaust Gas Recirculation-EGR

- Cools and mixes measured amounts of cooled exhaust gas with incoming fresh air to lower peak combustion temperatures, thereby reducing NOx

Variable geometry turbocharger (VGT)

- Varies exhaust pressure based on load and speed to ensure proper EGR flow and best-in-class fuel economy.

High-Pressure Common-Rail (HPCR) and Engine Control Unit (ECU)

- The HPCR fuel system provides variable common-rail pressure, multiple injections, and higher injection pressures up to 1,600 bar (23,000 psi). It also controls fuel injection timing and provides precise control for the start, duration, and end of injection.

4-Valve Cylinder Head

- The 4-valve cylinder head provides excellent airflow by utilizing a cross-flow design

Air-to-Air Aftercooled

- This is the most efficient method of cooling intake air to help reduce engine emissions. It enables an engine to meet emissions regulations with better fuel economy and the lowest installed costs

Compact Size

- Horsepower/displacement ratio is best-in-class
- Lower installed cost
- Mounting points are the same as previous engine models

John Deere Electronic Engine Controls

- Electronic engine controls monitor critical engine functions, providing warning and/or shutdown to prevent costly engine repairs and eliminate the need for add-on governing components, all lowering total installed costs.

Additional Features

- Self adjusting poly-vee fan drive
- Single-piece low-friction steel piston
- Low-pressure fuel system with electrical transfer pump and "auto-prime" feature
- Directed top-liner cooling