

PowerTech™ PVS 6068HFC08 Diesel Engine

Industrial Engine Specifications



6068HFC08 shown

Engine dimensions

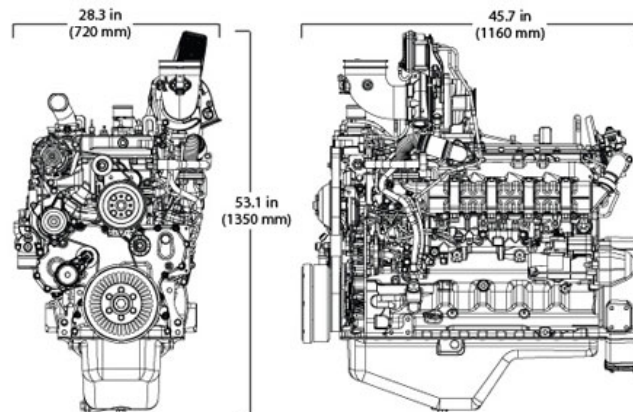

Dimensions may vary according to options selected. Call your distributor for more information.

Emissions

CARB
EPA Tier 4
EU Stage IV

General data

Model	6068HFC08	Length - mm (in)	1160 (45.7)
Number of cylinders	6	Width - mm (in)	720 (28.3)
Displacement - L (cu in)	6.8 (415)	Height-- mm (in)	1350 (53.1)
Bore and Stroke-- mm (in)	106 x 127 (4.17 x 5.00)	Weight, dry - kg (lb)	770 (1698)
Compression Ratio	17.2 : 1		
Engine Type	In-line, 4-cycle		
Aspiration	Turbocharged and air-to-air aftercooled		

Performance data range

Application ratings	Intermittent	Heavy Duty	Continuous
Rated power/Rated speed	168-187 kW(225-250 hp) @2000-2400rpm	149-168 kW(200-225 hp) @2000-2400rpm	104-149 kW(139-200 hp) @2200-2400rpm
Peak power	185-190 kW (248-255 hp) @1800-2200rpm	164-168 kW (220-225 hp) @1800-2400rpm	106-149 kW (142-200 hp) @2100-2400rpm
Power bulge	2-10% @ 1800-2200rpm	0-10% @ 1800rpm	0-2% @ 2000rpm
Peak torque	1000 N.m (738ft-lb) @1600rpm	900-963 N.m (664-710ft-lb) @1600rpm	613-800 N.m (452-590ft-lb) @1600rpm
Torque rise	25-34%	35%	35-36%

The Industrial Intermittent engine power rating is for applications that operate at varying loads and speeds, and do not fit the Industrial Heavy-Duty rating information.

Some applications require Industrial Heavy-Duty engine power ratings. Please contact your John Deere Power Systems engine distributor for more information.

The Industrial Continuous engine power rating is for applications that operate with constant load and speed, except for short periods during startup or shutdown.

Power output is within + or - 5% at standard SAE J 1995 and ISO 3046.

DOC/DPF Dimensions

Size	3	4
Diameter - mm (in)	246.6 (9.7)	259.3 (10.2)
Length - mm (in)	579.6 (22.8)	692.2 (27.3)
Weight - kg (lb)	30.8 (67.9)	33.6 (74.1)

See your John Deere Power Systems engine distributor for more information on available filter size options.

SCR Catalyst Dimensions

Size	3	4
Diameter - mm (in)	318 (12.5)	318 (12.5)
Length - mm (in)	638 (25.1)	750.9 (29.6)
Weight - kg (lb)	34 (75.0)	39 (86.0)

Features and Benefits

Ready to Run. Stage V.

- John Deere is ready to work, ready to generate, and ready to run with engines meeting EU Stage V emissions regulations. This means OEM customers currently using a John Deere engine with a diesel particulate filter (DPF) won't have to re-engineer their machine to meet the requirements of Stage V regulations. John Deere has been using DPF technology since Interim Tier 4/Stage III B, and is well positioned to help customers transition to the EU's Stage V standard. We have extensive experience with the development and integration of DPFs in both John Deere and OEM equipment, with more than 425 million DPF hours in the field.*



* Data compiled September 2016

Variable Geometry Turbocharger (VGT)

- Varies exhaust pressure based on load and speed to ensure proper EGR flow. The combination of the cooled EGR and VGT provide low-speed torque, quicker transient response, higher-peak torque, and world-class fuel economy.

Cooled Exhaust Gas Recirculation (EGR)

- EGR cools and mixes measured amounts of cooled exhaust gas with incoming fresh air to lower peak combustion temperatures, thereby reducing Nox.

Exhaust Filters

- These engines utilize a catalyzed exhaust filter that contains a diesel oxidation catalyst (DOC) and a diesel particulate filter (DPF). The DOC reacts with exhaust gases to reduce carbon monoxide, hydrocarbons, and some particulate matter (PM). The downstream DPF traps and holds the remaining PM. Trapped particles are oxidized within the DPF through a continuous cleaning process called passive regeneration. Passive regeneration occurs during normal operating conditions when heat from the exhaust stream and catalysts within the exhaust filter trigger the oxidation of the trapped PM. If passive regeneration cannot be achieved due to low temperature, load, or speed, then PM is removed using active regeneration — an automatic cleaning process controlled by the exhaust temperature management system. Engines below 130 kW (174 hp) use an in-cylinder dosing system for active regeneration, while larger engines use an external dosing system.

Selective catalytic reduction (SCR)

- John Deere engines feature an SCR system that utilizes a urea-based additive, sometimes referred to as diesel exhaust fluid (DEF). The ammonia in the urea mixes with engine exhaust gases in the SCR catalyst to reduce NOx — converting it to nitrogen and water vapor.

High-Pressure Common-Rail (HPCR) and Engine Control Unit (ECU)

- The HPCR fuel system provides variable common-rail pressure and higher injection pressures up to 2,500 bar (36,000 psi). It also controls fuel injection timing and provides precise control for the start, duration, and end of injection.

4-Valve Cylinder Head

- The 4-valve cylinder head provides excellent airflow resulting in greater low-speed torque and better transient response time by utilizing a cross-flow design.

Air-to-Air Aftercooled

- This is the most efficient method of cooling in take air to help reduce engine emissions while maintaining low-speed torque, transient response time, and peak torque. It enables an engine to meet emissions regulations with better fuel economy and the lowest installed costs.

Compact Size

- Lower installed cost
- Mounting points are the same as previous models

Engine Performance

- Multiple rated speeds to further reduce noise and improve fuel economy
- Low-speed (1000 rpm) torque equal to or better than Tier 4/Stage III B -
- Optional power bulge equal to or better than Tier 4/Stage III B

John Deere Electronic Engine Controls

- Faster engine control unit (ECU) manages both the engine and the aftertreatment system
- Four times the memory, twice the RAM and double the processing speed - The input/output capability has increased 40%
- Premium software option integrates with equipment or vehicles to reduce engineering and installation costs

Additional Features

- Glow plugs
- Gear-driven auxiliary drives
- 500-hour oil change
- Self-adjusting poly-vee fan drive
- Optional factory installed variable-speed fan drive improves fuel economy and reduces noise levels
- R.H. and L.H. engine-mounted final fuel filters
- Aluminum piston with integrated oil cooled gallery
- Low-pressure fuel system with electrical transfer pump and "auto-prime" feature