

PowerTech™ EWX 3029HFG03 Diesel Engine

Generator Drive Engine Specifications



3029HFG03 shown

Engine dimensions

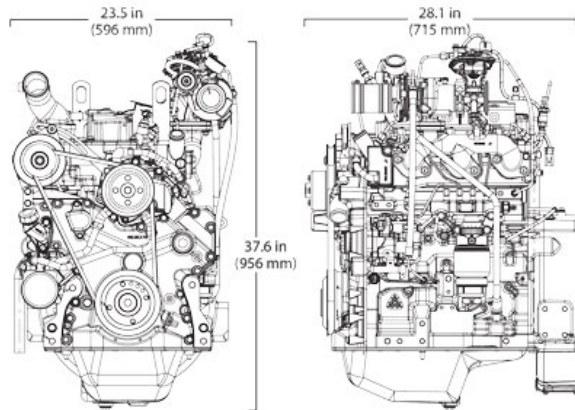

Dimensions may vary according to options selected. Call your distributor for more information.

Emissions

CARB

EPA Tier 4

General data

Model	3029HFG03	Length - mm (in) to rear of block	715 (28.1)
Number of cylinders	3	Width - mm (in)	596 (23.5)
Displacement - L (cu in)	2.9 (177)	Height-- mm (in)	956 (37.6)
Bore and Stroke-- mm (in)	106.5 x 110 (4.19 x 4.33)	Weight, dry - kg (lb)	400 (882)
Compression Ratio	16.9		
Engine Type	In-line, 4-Cycle		
Aspiration	Turbocharged and air-to-air aftercooled		

Performance data range

Rated speed	Engine power				Generator efficiency	Rated fan power		Power factor	Calculated generator set output			
	Prime		Standby			kW	hp		Prime		Standby	
	kW	hp	kW	hp					kWe*	kVA	kWe	kVA
60(1800)	33-50	44-67	36-55	48-74	88-92	1.4-2.2	1.9-3.0	0.8	28-44	35-55	30-49	38-61
50(1500)	33-44	44-59	36-48	48-64	88-92	1.4-1.9	1.9-2.5	0.8	28-39	35-48	30-42	38-53

Prime power is the nominal power an engine is capable of delivering with a variable load for an unlimited number of hours per year. This rating conforms to ISO3046 and SAE J1995.

Standby power is the maximum engine power available at varying load factors for up to 200 hours per year when applied to conform with ISO 8528-1. This rating conforms to ISO 3046 and SAE J1995. Calculated generator set rating range for standby applications is based on minimum engine power (nominal -5 percent) to provide 100 percent meet-or-exceed performance for assembled standby generator sets.

*Electrical power is calculated from the typical generator efficiency and fan power percentages shown. Applications may vary.

DOC/DPF Dimensions

Size	2
Diameter - mm (in)	209 (8.2)
Length - mm (in)	573 (22.6)
Weight - kg (lb)	20 (44.1)

See your John Deere Power Systems engine distributor for more information on available filter size options.

Features and Benefits

Wastegated Turbocharger

- Wastegated turbochargers are designed to develop more airflow at lower engine speeds to improve low-speed torque. The wastegate control device bleeds off a portion of the exhaust flow at higher engine speeds. Wastegated turbos deliver improved transient response and higher peak torque without compromising engine envelope size. They also provide the lowest installed cost across a given power range.

Exhaust Filters

- This system is the Best Available Control Technology (BACT) for particulates that delivers premium block load acceptance characteristics and utilize a catalyzed exhaust filter that contains a diesel oxidation catalyst (DOC) and a diesel particulate filter (DPF). The DOC reacts with exhaust gases to reduce carbon monoxide, hydrocarbons, and some particulate matter (PM). The downstream DPF traps and holds the remaining PM. Trapped particles are oxidized within the DPF through a continuous cleaning process called passive regeneration. Passive regeneration occurs during normal operating conditions when heat from the exhaust stream and catalysts within the exhaust filter trigger the oxidation of the trapped PM. If passive regeneration cannot be achieved due to low temperature, load, or speed, then PM is removed using active regeneration — an automatic cleaning process controlled by the exhaust temperature management system.

High-Pressure Common-Rail (HPCR) and Engine Control Unit (ECU)

- The HPCR fuel system provides variable common-rail pressure and higher injection pressures up to 2,500 bar (36,000 psi). It also controls fuel injection timing and provides precise control for the start, duration, and end of injection.

Air-to-Air Aftercooled

- This is the most efficient method of cooling intake air to help reduce engine emissions while maintaining low-speed torque, transient response time, and peak torque. It enables an engine to meet emissions regulations with better fuel economy and the lowest installed costs.

2-Valve Cylinder Head

- Cross-flow head design provides excellent breathing from a lower-cost 2-valve cylinder head.

Compact Size

- Lower installed cost
- Mounting points are the same as previous engine models

John Deere Electronic Engine Controls

- Faster engine control unit (ECU) manages both the engine and the exhaust filter
- JDLink™ lets you monitor, protect, and maintain your equipment 24/7
- Premium software option integrates with equipment or vehicles to reduce engineering and installation costs
- Electronic engine controls can be engine or remote mounted

Additional Features

- Gear-driven auxiliary drives
- 500-hour oil change
- Replaceable (wet) cylinder liners
- Oil-cooled pistons with hardened ring groove insert
- Engine-mounted final fuel filters
- Optional low-pressure fuel system with electrical transfer pump and "auto-prime" feature
- Single fluid solution
- Full flow engine mounted oil cooler