

1110G FORWARDER



JOHN DEERE





1110G FORWARDER

OPTIMIZED, NEVER COMPROMISED.

For over a half-century, our forward-thinking forwarders have been leading the way in the woods. Then we put some serious thought from loggers like you into making them even more productive. Proven components like a durable boom, robust and reliable axles, plus streamlined electrical systems are a few of your best ideas designed to help our machines withstand the toughest logging environments. The versatile John Deere 1110G Forwarder is built to deliver uncompromising performance for your operation.

Turn things around

Rotating and smooth-leveling cab turns 290 degrees, providing 360-degree visibility of boom movements and the surrounding jobsite, for safe, efficient log loading. Optional rotating and leveling suspended cab keeps operators balanced and comfortable in steep and uneven terrain.

Smart solution

Optional Intelligent Boom Control (IBC) makes boom operations more precise and productive compared to the same machine not equipped with IBC. Joysticks configurable to user preference let operators run their preferred control pattern. IBC makes load handling more efficient and boosts productivity.

Fan favorite

Hydraulic-driven variable-speed fan available in the 1110G runs only as needed, reducing fuel consumption and debris flow through the cooler cores. Program it to reverse at periodic intervals to clear core-clogging buildup.



ROTATING/LEVELING CAB TURNS 290°
FOR 360° VISIBILITY

Work your way

Choose the driving mode that matches conditions, and Adaptive Driveline Control automatically adjusts engine load to keep rpm steady. Select **Normal** for everyday operation or **Power** in high-load situations. For lighter demands, **Economy** reduces engine speed and noise, while improving fuel efficiency.

Take the long view

Long-bogie configuration available for the 1110G delivers lower ground pressure than standard bogie models, for logging in soft terrain. It also improves the sideways stability of the rear frame while driving.

Never fall short

The 1110G Forwarder is also available with a wheelbase that's 40 centimeters (15¾ inches) shorter, for better agility in thinning applications without sacrificing stability or load size.

1110G FORWARDER



PUT TECHNOLOGY TO WORK IN THE WOODS AND AT THE OFFICE.

Coordinate your operation and your team's productivity from wherever your work takes you with John Deere Precision Forestry and our core technology solutions.

FEATURES

Core intelligence

Your John Deere Forestry machine arrives from the factory equipped with a powerful set of technologies and capabilities already built in. Each plays an important role in managing the health and performance of your overall equipment fleet:

- **JDLink™ connectivity and the John Deere Operations Center™** let you track your equipment, see which machines are working, and know if they're being utilized properly and at maximum productivity and efficiency.
- **John Deere Connected Support** leverages a suite of dealer and factory tools designed to deliver increased uptime and productivity, and lower daily operating costs.
- **Remote Diagnostics and Programming Capability** within John Deere Connected Support helps your dealer warn you of any issue with your machine — often before you know of the problem yourself — and initiate solutions without charging you for a technician's visit to your jobsite.
- Our advanced dual approach to **Machine Health** combines the expertise of the technology specialists at our dealerships with the data specialists at our central Machine Health Monitoring Center (MHMC). As part of John Deere Connected Support, information from thousands of connected machines flows through the MHMC, enabling our specialists to identify trends and develop new and improved preventative-maintenance and repair protocols.

Precision Forestry

Take the guesswork out of planning, implementing, and monitoring your logging operation. The tools of our production-planning and -tracking system expand on the core technology features that come standard in every John Deere Forestry machine to unleash a powerful new array of possibilities:

- **TimberMatic™ Maps** is an innovative onboard software solution that helps you reimagine your jobsites. Real-time production views and shared wireless connections between machines make it easier than ever before to take your forestry operation to the next level.
- **TimberManager™** is a web-based solution for PCs, tablets, and mobile phones that allows you to follow jobsite progress. Combined with TimberMatic Maps, this software provides complete visibility of your operation — from land harvested to specific machines — so you can streamline communication, analyze tasks, and increase productivity:
- **Remote Monitoring** keeps tabs on the health and performance of your fleet from wherever you are.
- **Precise Progress Tracking** lets you set goals for your team to meet throughout the day.
- **Live Production View** displays production progress by assortment, timber volume harvested, and volume transported to roadside storage.
- **Simplified Mapping** of machine data and GPS-based location tracking shows production by assortment.
- **Real-Time Updates** let you adjust course or eliminate tasks if needed to maintain steady workflow.
- **Fleet Optimization** goes beyond machine management to help improve the efficiency of your business.



**JOHN DEERE
CONNECTED
SUPPORT™**
CONNECTS YOUR
OPERATION TO DEALER
& FACTORY EXPERTISE

1110G FOWARDER SPECIFICATIONS

Engine		1110G 6WD / 8WD	
Load Rating	12 000 kg (26,455 lb.)		
Manufacturer and Model	John Deere PowerTech™ Plus 6068		
Non-Road Emissions Standard	EPA Final Tier 4/EU Stage V / EU Tier 2/Stage II		
Net Peak Power	145 kW (194 hp) at 1,600–1,900 rpm		
Net Peak Torque	865 Nm (638 ft.-lb.) at 1,300–1,600 rpm		
Fuel Tank Capacity	167 L (44 gal.)		
Transmission			
Hydrostatic-mechanical, 2-speed gearbox			
Tractive Force	160 kN (35,968 lbf.)		
Travel Speed			
Gear 1	0–7.5 km/h (0–4.3 mph)		
Gear 2	0–23 km/h (0–14.3 mph)		
Steering			
Proportional steering with electrical joystick			
Turning Angle	44 deg.		
Brakes			
Service	Hydraulically actuated, oil-immersed, multi-disc		
Parking/Emergency	Spring actuated		
Frame	Automated		
Axles/Bogies			
Differential lock in front and rear			
Axles			
Front	Single rigid axle, non-balanced- or balanced-gear bogie axle		
Rear	Balanced-gear bogie axle or unbalanced long bogie (LGP)		
Electrical			
Voltage	24 volt		
Batteries	145 Ah		
Alternator	150 A		
Lights	LED		
Hydraulics			
Load sensing			
Pump Capacity	140 cm ³ (9.0 cu. in.)		
Operating Pressure	24 MPa (3,480 psi)		
Hydraulic Tank	161 L (43 gal.)		
Boom			
Type	CF5	CF7	
Maximum Reach Lengths	8.5 m (27.9 ft.) / 10 m (32.8 ft.)	8.5 m (27.9 ft.) / 10 m (32.8 ft.)	
Gross Lifting Torque	102 kNm (75,000 ft.-lb.)	125 kNm (92,000 ft.-lb.)	
Slewing Torque	24 kNm (18,000 ft.-lb.)	32 kNm (24,000 ft.-lb.)	
Slewing Angle	380 deg.		
Cabin			
Type	Fixed, rotating, or rotating and leveling		
Rotating Angle	290 deg.		
Tilt			
Sideways	10 deg.		
Forward and Backward	6 deg.		
Control System			
PC / Windows®-based TimberMatic™ F-16			
Boom Control Aid			
Standard	Smooth Boom Control (SBC) algorithm		
Optional	Intelligent Boom Control (IBC) on CF5 and CF7		

While general information, pictures, and descriptions are provided, some illustrations and text may include product options and accessories NOT AVAILABLE in all regions, and in some countries products and accessories may require modifications or additions to ensure compliance with the local regulations of those countries.

Measurements		1110G 6WD / 8WD	
A Length		F Width	
Short / Medium Wheelbase	9820 mm (32.2 ft.)	600-Series Tires	2700 mm (8.9 ft.)
Long Wheelbase	10 820 mm (35.5 ft.)	700-Series Tires	2890 mm (9.5 ft.)
B Bogie Center – Middle Joint	1900 mm (6.2 ft.)	800-Series Tires	2990 mm (9.8 ft.)
C Middle Joint – Bogie Center		Turning Angle	44 deg.
Short Wheelbase	3000 mm (9.8 ft.)	Outer Turning Radius – 700-Series Tires	
Medium Wheelbase	3400 mm (11.2 ft.)	Short	7835 mm (25.7 ft.)
Long Wheelbase	3800 mm (12.5 ft.)	Medium	8400 mm (27.6 ft.)
Wheelbase (B+C)		Long	8980 mm (29.5 ft.)
Short	4900 mm (16.1 ft.)	Inner Turning Radius – 700-Series Tires	
Medium	5300 mm (17.4 ft.)	Short	4400 mm (14.4 ft.)
Long	5700 mm (18.7 ft.)	Medium	4820 mm (15.8 ft.)
D Headboard – Bogie Center		Long	5230 mm (17.2 ft.)
Short Wheelbase	2200 mm (7.2 ft.)	Transport Height	3870 mm (12.7 ft.)
Medium Wheelbase	2600 mm (8.5 ft.)	G Ground Clearance – 8W	660 mm (26.0 in.)
Long Wheelbase	3000 mm (9.8 ft.)	Tires	
E Bogie Center – Rear		Front – 6W / 8W	34–14 / 26.5–20
Short Wheelbase	2300 mm (7.5 ft.)	Rear	26.5–20
Medium Wheelbase	1900 mm (6.2 ft.)	Minimum Machine Weight	
Long Wheelbase	2500 mm (8.2 ft.)	6W	15 330 kg (33,797 lb.)
		8W	17 130 kg (37,765 lb.)
		Approach Angle – 8W	35 deg.
Load-Space Options			
Load Space Length (D+E)			
Short / Medium Wheelbase	4500 mm (14.8 ft.)		
Long Wheelbase	5500 mm (18.0 ft.)		
Load-Space Width			
Minimum / Maximum	2700 mm (8.9 ft.) / 3149 mm (10.3 ft.)		
Cross-Sectional Area	4.0–4.6 m ² (43.0–49.5 sq. ft.)		

1110G Forwarder

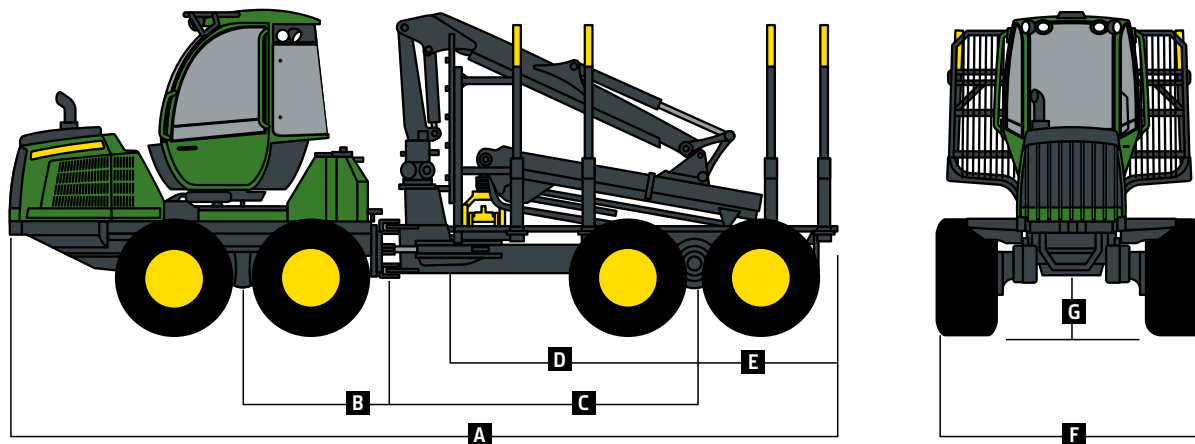



MF01110GF (23-09)

Contact us to learn more.
JohnDeere.com/Forwarders
JohnDeere.ca/Forwarders

