



JOHN DEERE

Series 1400 TeamMate™ II Axles

Funk™ Drivetrain Specifications



1400 SWEDA™ axle shown

General data

Peak vertical load 300,000 N (67,000 lb)
 Peak axle torque 47,400 Nm (420,000 in-lb)

Oil
 Capacity 28 L (30 qt)

Flange to flange
 Narrow 1700 mm (66.93 in)
 Standard 1953 mm (76.89 in)
 For 6.4 final drive ratio 110 mm (4.33 in)

Reduction ratios: 12

Minimum 16.208:1
 Maximum 32.914:1

Weight

Approximate 862 kg (1900 lb)

Diff lock

- Standard
- No-spin diff lock
- Hydraulic diff lock

Dimensions

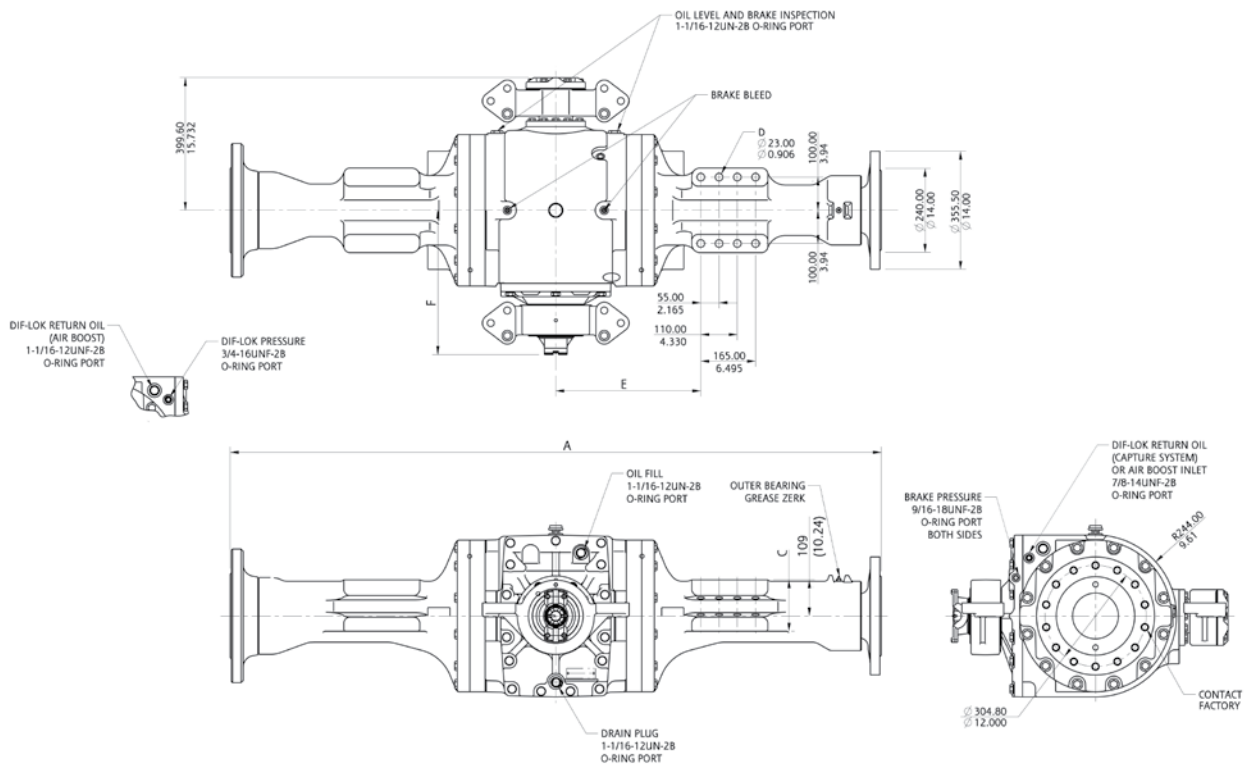

Specifications and design subject to change without notice. Ratings may vary depending on application and service. Application and installation are subject to review by John Deere.

Photograph may show non-standard equipment.

Features and benefits

Custom features

- Inboard planetary final drive design
 - Increases tire size flexibility since the planetary does not compete for wheel space
 - Enables wider variety of acceptable track widths than outboard designs
 - One integral oiling and cooling system
 - Reduces heat transfer to tires
- Independent or dual-service brake actuation
- Spiral bevel gear set design allows bidirectional operation
- Input housings designed for use with oscillation hardware
- Spring-applied hydraulic release or manually applied parking brakes on fixed mounted axles
- Inboard wet brakes increase reliability and provide spark-free operation for regulatory compliance in hazardous environments
- One oil supply for all planetary, brake, and differential components for better cooling

Cost-effectiveness

John Deere can custom build an axle to your specific torque and load requirements. Our building-block design consists of 12 modules of varying sizes, load capacities, ratios, and specifications. The best torque and load carrying capacity will be selected based on your application.

- Three axle families to better match your requirements
- Gray or ductile iron axle housings for improved load-matching
- Standard or heavy-duty wheel bearings
- Standard or extra-wide planetaries for better torque, shock, and reverse load-matching

Long axle life

- Final drives, spiral bevel gear set, and structural components designed for extreme applications
- Planetaries not packaged into the wheel, allowing for larger size, making torque and forward-reverse transitions reliable
- Sliding tooth contact spiral bevel gear set is minimized for longer life
- Large oil sump ensures cool operation, prolonging life of the spiral bevel gear set, final drives, differential bearings, and pinion bearings
- Inboard wet disc brakes protected from contaminants and last up to four times longer than dry disc brakes
- Inboard wet disc brakes operate cooler and last longer due to large sump
- No brake lines at the wheel end that require protection
- Inboard wet brakes provide spark-free operation for regulatory compliance in hazardous environments

Reliability

- Application engineers ensure axle specifications meet your vehicle torque, load, and operating performance requirements

Performance data

Axle Load Chart

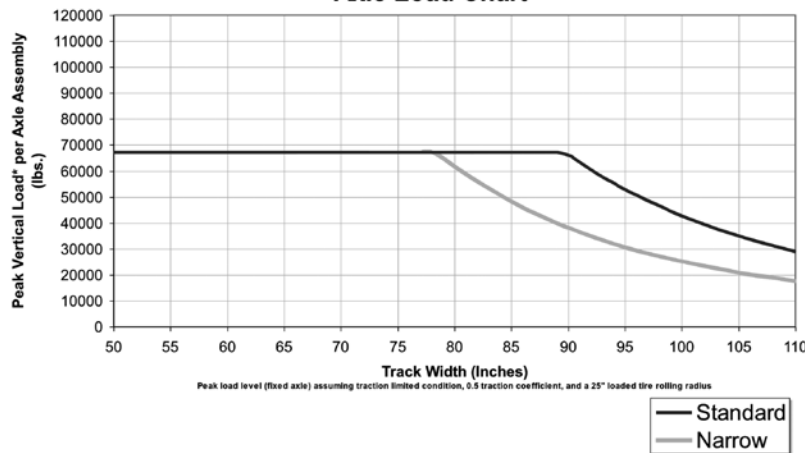

John Deere Power Systems
 3801 W. Ridgeway Ave.
 P.O. Box 5100
 Waterloo, IA 50704-5100
 Phone: +1 800 553 6446
 Fax: +1 319 292 5075
 E-mail: jdpower@JohnDeere.com
www.JohnDeere.com/jdpower

John Deere Power Systems
 Doornelei, 24
 2018 Antwerpen
 Belgium
 Phone: +32 3 238 89 69
 Fax: +32 3 248 54 98