

FILTER OVERVIEW WITH SERVICE INTERVALS AND CAPACITIES

7R Tractor(s) Final Tier 4 (FT4) (110101-) - 7R 210, 7R 230, 7R 250, 7R 270, 7R 290, 7R 310 And 7R 330

ENGINE
PRIMARY FUEL FILTER
 FILTER ELEMENT (9L) - [RE539465](#)
 FILTER ELEMENT (6.8L) - [DZ115391](#)
 Replace after every 500 hours, or as indicated, whichever occur first.

ENGINE
ENGINE OIL FILTER
 FILTER ELEMENT (9L) - [RE509672](#)
 FILTER ELEMENT (6.8L) - [RE539279](#)

Minimum hours before first engine oil change is 100 hours. Extended engine oil change every 500 hours or annually, whichever come first. The extended 500 hours interval is only allowed if using Plus-50™ II oil with a John Deere™ filter and diesel fuel with sulfur content less than 15mg/kg (15ppm). If all the conditions are not met, change oil and filter at 250 hours of operation.

ENGINE
OCV FILTER ELEMENT (6.8L) - [DZ105100](#)
 Replace after every 1500 hours.

ENGINE
FRONT PTO OIL FILTER - [LVU14258](#)
 Initial change at 250 hours, then replace every 1500 hours.

ENGINE
PRIMARY AIR FILTER - [RE564863](#)
 Replace after every 1000 hours, or as indicated, whichever occur first. (Interval may vary according to operating conditions).

ENGINE
SECONDARY FUEL FILTER
 FILTER ELEMENT (9L) - [DZ112918](#)
 FILTER ELEMENT (6.8L) - [DZ115392](#)
 Replace after every 500 hours, or as indicated, whichever occur first.

ENGINE
SECONDARY AIR FILTER - [F071151](#)
 Replace after every 1000 hours, or as indicated, whichever occur first. (Interval may vary according to operating conditions).

ENGINE
FUEL WATER SEPERATOR FILTER (IF EQUIPPED) - [AT365869](#)
 Replace after every 500 hours.

ENGINE
DEF INLINE FILTER - [DZ110513](#)
 Replace after every 3000 operating hours or 3 years, whichever comes first.

CAB
FRESH AIR FILTER - [RE284091](#)
 Replace every 1000 hours or annually, whichever occurs first. (Interval may vary according to operating conditions).

SCV
OIL FILTER - [RE269061](#)
 Replace after every 1500 hours.

ENGINE
FUEL TANK VENT FILTER - [H216169](#)
 Replace after every 1500 hours.

CAB
RECIRCULATION AIR FILTER - [RE593819](#)
 Replace every 1000 hours or annually, whichever occurs first. (Interval may vary according to operating conditions).

ENGINE
DEF TANK VENT FILTER - [H216169](#)
 Replace after every 1500 hours.

HYDRAULIC OIL FILTER ELEMENT - [RE577612](#)
 Replace after every 1500 hours.

ENGINE
DEF SUPPLY MODULE FILTER - [DZ114640](#)
 Replace after every 3000 operating hours or 3 years, whichever comes first.

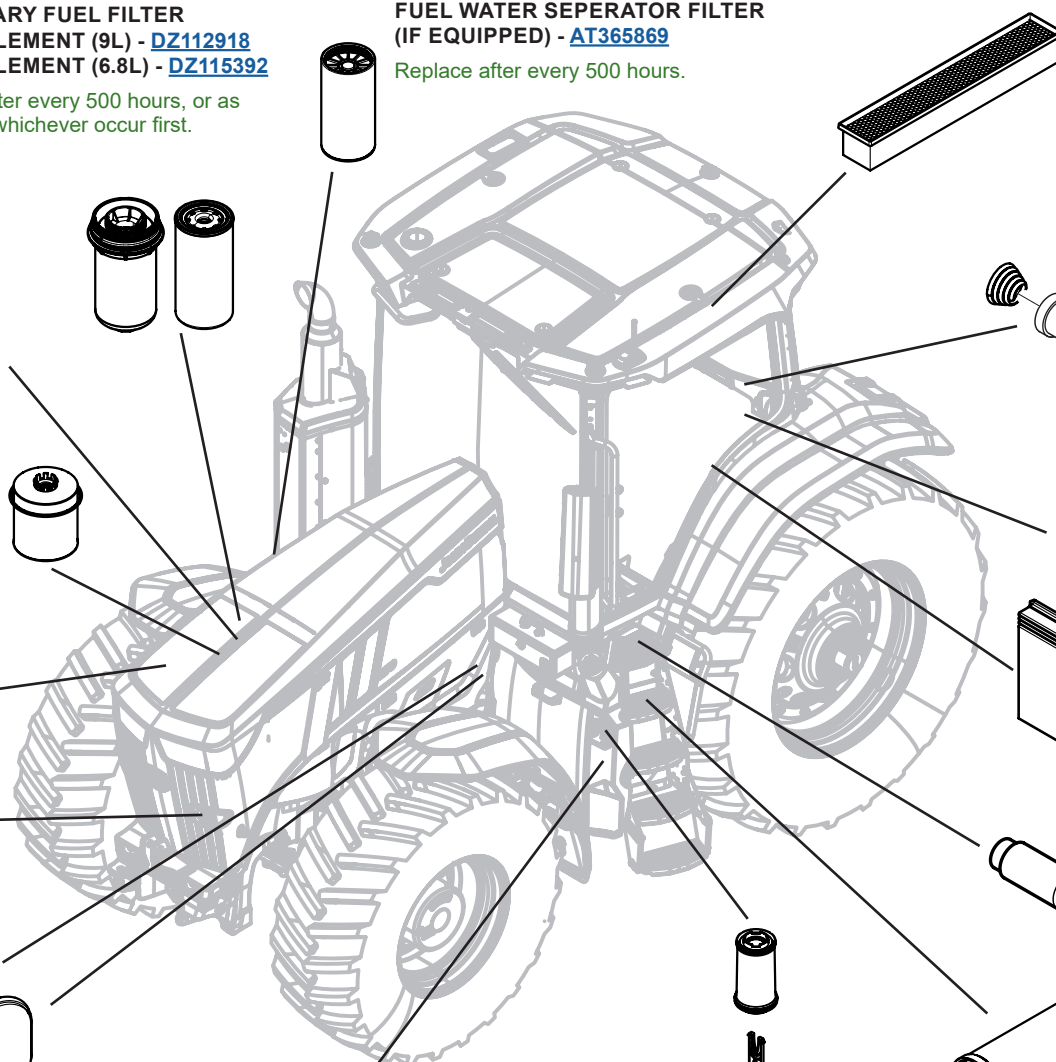

CAPACITIES

7R Tractor(s) Final Tier 4 (FT4) (110101-) - 7R 210, 7R 230, 7R 250, 7R 270, 7R 290, 7R 310 And 7R 330

CAPACITIES (Approximate):

Cooling System:

Cool-Gard™ II

7R 210, 230, 250, 270 39.5 L (10.4 gal)

7R 290, 310, 330 44.5 L (11.75 gal)

Engine Crankcase Oil Volume, Including Filter:

7R 210, 230, 250, 270 26 L (6.8 gal)

7R 290, 310, 330 23 L (6 gal)

Fuel Tank:

e23™ 463 L (122 gal)

IVT™/AutoPowr™ 513 L (135 gal)

DEF Tank:

..... 26.2 L (6.9 gal)

Final Drive (Each):

With Brakes / Without Brakes 3.8 L (1 gal)

Transmission / Hydraulic System:

e23™ and IVT™/AutoPowr™ 160 L (42.3 gal)

Front PTO Oil 4 L (1.1 gal)

TLS™ Plus Axle:

With Differential Lock 10.8 L (2.8 gal)

With Limited Slip 14.4 L (3.8 gal)

1150, 1300 MFWD Axle:

..... 14.4 L (3.8 gal)

[Return to Filter Overview](#)

