

# 859MH TRACKED HARVESTER



JOHN DEERE



## 859MH TRACKED HARVESTER

# BUILT FOR WORK IN THE REAL WORLD.

Keeping up in the woods and at the landing can be some of the hardest work you do. So when you asked for job-proven mid-size might to help get things done, we took it from there. The result is a tracked harvester equipped with standard Smooth Boom Control (SBC) for exceptional command. A long and wide undercarriage for sturdy stability. Dual-swing drive for powerful performance. Uncompromising cab comfort and visibility. Plus a range of available options to suit your application including Intelligent Boom Control (IBC) for optimized control and operation. It all adds up to a purpose-built machine designed to work for you.

### Smooth operation

Smooth Boom Control (SBC) allows machine movements to be controlled more effectively, delivering a smoother experience for the operator and less wear and tear on the machine over time.

### Sure-footed stability

Generous tractive effort enables reliable negotiation of difficult or steep terrain, deep snow, and swamps. Long and wide undercarriage combined with our industry-leading leveling system maximizes stability on steep slopes and other challenging terrain conditions.

### Comfortable control

Ergonomically designed controls and seat with dual-density seat pan and contour plus updated armrest and suspension boost overall operator comfort. Options such as heated-ventilated seat (HVS) and updated premium Bluetooth® radio with XM Satellite Radio ready from the factory take comfort to the next level.

### Dedicated to your work

When equipped with the Dedicated Travel System feature, a 330-hp engine option can be selected to further improve the performance and efficiency of the Travel System and all other machine functions.

### Reach beyond

Extended stick option for the 859MH enables a longer reach to minimize the number of cut trails and enhance machine efficiency.

### Expansive visibility

Floor-to-ceiling front window, large side windows, skylight, and optional floor window (standard with the undercarriage-leveling mechanism) significantly expand the view of the harvesting area and the work at hand.

### Smart debris management

Designed to keep your workspace free and clear, the productivity-boosting debris-management system is integrated into the hood and left-side guarding to prevent materials and debris from entering the cooling package. External screening, sealed cooler compartment, and standard variable-speed reversing fan provide protection as needed.

### Level the playing field

An available option on the 859MH Tracked Harvester, our industry-leading slope-monitoring system measures the actual ground-slope angle the machine is working on and displays it on the in-cab monitor, for more confident operation in tough steep-slope conditions and potentially greater overall efficiency.



# TAKE CONTROL WITH IBC

## **Boost productivity from the get-go**

Optional Intelligent Boom Control (IBC) smoothes boom operation, making it more precise and efficient.

## **Nice and precise**

IBC improves the precision of attachment positioning, especially at extended reaches. Joystick movements deliver consistently smooth boom speed, no matter how far the boom is extended.

## **Effortless control**

With IBC, operators no longer need to control each independent boom function separately. Just control the attachment position, and IBC automatically guides the boom and cylinders accordingly. IBC also automatically controls swing speed based on the overall position of the attachment.

## **Choose how you work**

IBC is easily configurable to user preference, so operators can adapt their motions to the application. The IBC control pattern that works best for each operator can also be selected, further enhancing personal ease of use. Individual user settings can be saved in up to eight separate profiles, to accommodate multiple skill and experience levels.



**IBC ENABLES *PRECISE*  
BOOM MOVEMENTS**

859MH TRACKED HARVESTER

# PUT TECHNOLOGY TO WORK IN THE WOODS AND AT THE OFFICE.

Coordinate your operation and your team's productivity from wherever your work takes you with John Deere Precision Forestry and our core technology solutions.





## JDLINK™ CONNECTIVITY

NO ADDITIONAL COST  
NO SUBSCRIPTIONS  
NO RENEWAL DATES

## FEATURES

### Core intelligence

Your John Deere Forestry machine arrives from the factory equipped with a powerful set of technologies and capabilities already built in. Each plays an important role in managing the health and performance of your overall equipment fleet:

- **JDLink connectivity** lets you track your equipment, see which machines are working, and know if they're being utilized properly and at maximum productivity and efficiency.
- Enabled through JDLink, **John Deere Connected Support™** leverages a suite of dealer and factory tools designed to deliver increased uptime and productivity, and lower daily operating costs.
- **Remote Diagnostics and Programming Capability** within John Deere Connected Support helps your dealer warn you of any issue with your machine — often before you know of the problem yourself — and initiate solutions without charging you for a technician's visit to your jobsite.
- Our advanced dual approach to **Machine Health** combines the expertise of the technology specialists at our dealerships with the data specialists at our central Machine Health Monitoring Center (MHMC). As part of John Deere Connected Support, information from thousands of connected machines flows through the MHMC, enabling our specialists to identify trends and develop new and improved preventative-maintenance and repair protocols.

### Precision Forestry

Take the guesswork out of planning, implementing, and monitoring your logging operation. The tools of our production-planning and -tracking system expand on the core technology features that come standard in every John Deere Forestry machine to unleash a powerful new array of possibilities:

- **TimberMatic™ Maps** is an innovative onboard software solution that helps you reimagine your jobsites. Real-time production views, optimized routes, and shared wireless connections between machines make it easier than ever before to take your forestry operation to the next level.
- **TimberManager™** is a web-based solution for PCs, tablets, and mobile phones that allows you to follow jobsite progress. Combined with TimberMatic Maps, this software provides complete visibility of your operation — from land harvested to specific machines — so you can streamline communication, analyze tasks, and increase productivity:
  - **Remote Monitoring** keeps tabs on the health and performance of your fleet from wherever you are.
  - **Precise Progress Tracking** lets you set goals for your team to meet throughout the day.
  - **Live Production View** displays progress including tree count, area harvested, and estimated tonnage.
  - **Simplified Mapping** of machine data and GPS-based location tracking shows precise stem and log counts.
  - **Real-Time Updates** let you adjust course or eliminate tasks if needed to maintain steady workflow.
  - **Fleet Optimization** goes beyond machine management to help improve the efficiency of your business.

# 859MH TRACKED HARVESTER SPECIFICATIONS

Engine				
<b>859MH</b>				
Manufacturer and Model	John Deere PowerTech™ PSS 9.0L		John Deere PowerTech™ Plus 6090H	
Non-Road Emission Standard	EPA Final Tier 4/EU Stage V		EPA Tier 3/EU Stage IIIA / EPA Tier 2/EU Stage II	
Cylinders	6		6	
Displacement	9.0 L (549 cu. in.)		9.0 L (549 cu. in.)	
Peak Power at 1,900 rpm	<i>Standard Travel</i>	<i>Dedicated Travel</i>	<i>Standard Travel</i>	<i>Dedicated Travel</i>
	224 kW (300 hp)	246 kW (330 hp)	224 kW (300 hp)	246 kW (330 hp)
Net Peak Torque at 1,500 rpm	1270 Nm (937 lb.-ft.)	1392 Nm (1,027 lb.-ft.)	1270 Nm (937 lb.-ft.)	1392 Nm (1,027 lb.-ft.)
Cooling				
Fan Type	Suction type, hydraulically driven, variable speed, reversing			
Hydraulics				
Closed center, load sense, pressure compensated				
Standard Travel System			Dedicated Travel System	
<b>Main Pump</b>	Variable-displacement axial piston		<b>Main Pump</b>	Variable-displacement axial piston
Maximum Rated Flow	532 L/min. (141 gpm)		Maximum Rated Flow	494 L/min. (131 gpm)
<b>Attachment Pump</b>	Dedicated variable-displacement axial piston		<b>Travel Pump</b>	Dedicated variable-displacement axial piston
Maximum Rated Flow	209 L/min. (55 gpm)		Maximum Rated Flow (x2)	190 L/min. (50 gpm)
			<b>Attachment Pump</b>	Dedicated variable-displacement axial piston
			Maximum Rated Flow	181 L/min. (48 gpm)
Oil Filtration	2 main return filters, 10-micron return with bypass, 1 case-drain strainer, 25 micron			
Electrical				
	<i>EPA Final Tier 4/EU Stage V</i>		<i>EPA Tier 3/EU Stage IIIA / EPA Tier 2/EU Stage II</i>	
Voltage	24 volt		24 volt	
Number of Batteries	2 x 12 volt		2 x 12 volt	
Alternator Rating	200-amp standard		100-amp standard, 130-amp optional	
Work Lights	LED (13)		LED (13)	
Service Lights	LED (2)		LED (2)	
Undercarriage				
Integral track guides, thick high-abrasion-resistant material, ramp angles, hydraulic track adjustment				
Size	U7L Extreme Duty (EXD)		Travel Performance	<i>Standard Travel</i> <i>Dedicated Travel</i>
Track Chain	215.9 mm (8.5 in.)		Travel Speed, Forward and Reverse	
Number of Track Links (per side)	47		High	3.6 km/h (2.2 mph)      4.1 km/h (2.5 mph)
Lower Rollers (per side)	10		Low	1.7 km/h (1.0 mph)      1.8 km/h (1.1 mph)
Carrier Slides/Rollers (per side)	2		Tractive Effort	373 kN (83,876 lbf)      357 kN (80,257 lbf)
Rotating Upper				
Swing System, Standard				
Swing Speed (maximum)	6.8 rpm			
Swing Torque	94 740 Nm (69,880 lb.-ft.)			
Swing Brake	Sealed wet multi-disc, manually applied/released			
Serviceability				
<b>Refill Capacities</b>	<i>EPA Final Tier 4/EU Stage V</i>		<i>EPA Tier 3/EU Stage IIIA / EPA Tier 2/EU Stage II</i>	
Fuel Tank	870 L (228.9 gal.)		870 L (228.9 gal.)	
Diesel Exhaust Fluid (DEF)	34 L (8.9 gal.)		N/A	
Ground Pressure (SAE J1309)				
Includes standard equipment, 7.75-m (25 ft. 5 in.) boom, medium extended counterweight, half-full fuel tank, and all fluids, less attachment				
Undercarriage	<i>EPA Final Tier 4/EU Stage V</i>		<i>EPA Tier 3/EU Stage IIIA / EPA Tier 2/EU Stage II</i>	
	U7L EXD		U7L EXD	
Double Grouser				
610 mm (24 in.)	70.0 kPa (10.2 psi)		69.3 kPa (10.1 psi)	
Single Grouser				
610 mm (24 in.)	69.6 kPa (10.1 psi)		68.9 kPa (10.0 psi)	
711 mm (28 in.)	60.4 kPa (8.8 psi)		59.8 kPa (8.7 psi)	
Operating Weight				
Includes standard equipment, 7.75-m (25 ft. 5 in.) boom, medium extended counterweight, 610-mm (24 in.) single-grouser tracks, half-full fuel tank, and all fluids, less attachment				
Undercarriage	<i>EPA Final Tier 4/EU Stage V</i>		<i>EPA Tier 3/EU Stage IIIA / EPA Tier 2/EU Stage II</i>	
	U7L EXD		U7L EXD	
Approximate Weight — Base Machine	36 220 kg (79,870 lb.)		35 860 kg (79,070 lb.)	

Boom Performance		859MH
<b>9.91-m (32 ft. 6 in.) Boom</b>		
<b>Lift Option</b>		
Lift Capacity, Bare Pin at 9.91 m (32 ft. 6 in.) at Full Reach	3500 kg (7,718 lb.)	
Lift Capacity, Bare Pin at 6.10 m (20 ft.)	8130 kg (17,927 lb.)	
<b>8.84-m (29 ft. 0 in.) Boom</b>		
<b>Lift Option</b>		
Lift Capacity, Bare Pin at Full Reach	4190 kg (9,240 lb.)	
Lift Capacity, Bare Pin at 7.62 m (25 ft.)	5850 kg (12,900 lb.)	
Lift Capacity, Bare Pin at 6.10 m (20 ft.)	7700 kg (16,980 lb.)	
<b>7.75-m (25 ft. 5 in.) Boom</b>		
<b>Lift Option</b>		
Lift Capacity, Bare Pin at 7.62 m (25 ft.) at Full Reach	5520 kg (12,170 lb.)	
Lift Capacity, Bare Pin at 6.10 m (20 ft.)	8350 kg (18,410 lb.)	

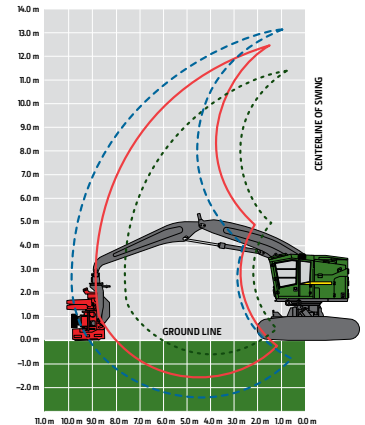

Attachment Information				
Attachment	HTH616C	HTH622B <sup>†</sup>	HTH623C <sup>†</sup>	HTH624C*
Maximum Cutting Capacity	550 mm (21.7 in.)	750 mm (29.5 in.)	750 mm (29.5 in.)	810 mm (31.9 in.)
Maximum Delimiting Capacity	510 mm (20.1 in.)	640 mm (25.2 in.)	700 mm (27.6 in.)	760 mm (29.9 in.)
Feeding Mechanism	3 rollers, fully synchronized hydraulic drive		3 rollers, fully synchronized hydraulic drive	
<b>Dimensions</b>				
Maximum Width (arms open)	1600 mm (63.0 in.)	1700 mm (66.9 in.)	2000 mm (78.7 in.)	2000 mm (78.7 in.)
Height (including rotator)	2350 mm (92.5 in.)	2700 mm (106.3 in.)	3000 mm (118.1 in.)	3000 mm (118.1 in.)
Weight (rotator and standard link)	1870 kg (4,120 lb.)	2190 kg (4,830 lb.)	2870 kg (6,330 lb.)	3460 kg (7,630 lb.)

\*With 7.75-m (25 ft. 5 in.) boom only. / <sup>†</sup>Not available with 9.91-m (32 ft. 6 in.) boom. See individual Harvesting Head brochure for more details.

Machine Dimensions			
Standard Undercarriage		U7L EXD	
<b>A</b> Overall Height With 8.84-m (29 ft. 0 in.) Boom		<b>E</b> Boom Reach (to attachment pin) (continued)	
Top of Cab With Flat Skylight	3.92 m (12 ft. 10 in.)	Optional 7.75-m (25 ft. 5 in.) Boom	
Top of Cab With Peaked Skylight	4.13 m (13 ft. 7 in.)	Maximum	7.75 m (25 ft. 5 in.)
Top of Boom, Extended, Attachment Vertical	4.70 m (15 ft. 5 in.)	Minimum	2.31 m (7 ft. 7 in.)
<b>B</b> Overall Track Length	4.90 m (16 ft. 1 in.)	Cutting Swath	5.44 m (17 ft. 10 in.)
<b>C</b> Track Length (idler to sprocket center)	3.83 m (12 ft. 7 in.)	<b>F</b> Ground Clearance	
<b>D</b> Tail Swing (from swing center)		Single Grouser	748 mm (29 in.)
Small and Medium Counterweight	1.94 m (6 ft. 4 in.)	Double Grouser	725 mm (29 in.)
Medium Extended Counterweight	2.25 m (7 ft. 4 in.)	<b>G</b> Upperstructure Width	
<b>E</b> Boom Reach (to attachment pin)		Standard	3.15 m (10 ft. 4 in.)
Optional 9.91-m (32 ft. 6 in.) Boom		With Optional Walkway	3.36 m (11 ft. 0 in.)
Maximum	9.91 m (32 ft. 6 in.)	<b>H</b> Track Gauge	2.72 m (8 ft. 11 in.)
Minimum	3.45 m (11 ft. 4 in.)	<b>I</b> Width Over Tracks	
Cutting Swath	6.46 m (21 ft. 2 in.)	610-mm (24 in.) Track Shoes	3.33 m (10 ft. 11 in.)
Standard 8.84-m (29 ft. 0 in.) Boom		711-mm (28 in.) Track Shoes	3.43 m (11 ft. 3 in.)
Maximum	8.84 m (29 ft. 0 in.)		
Minimum	2.71 m (8 ft. 11 in.)		
Cutting Swath	6.13 m (20 ft. 1 in.)		

### 859MH Tracked Harvester

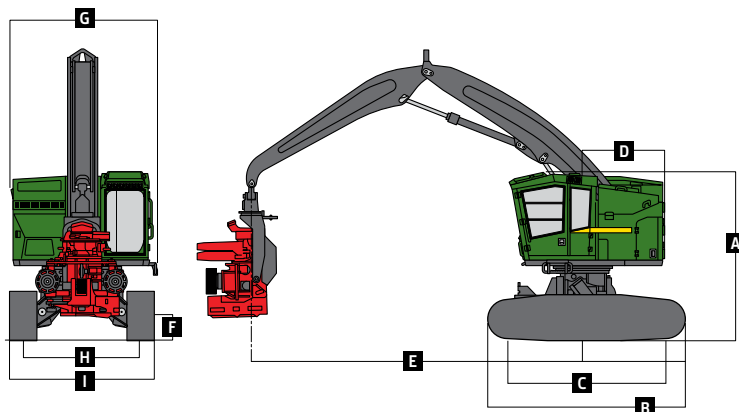

### 859MH Leveling

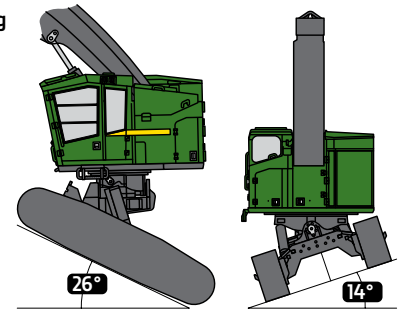

859MH Undercarriage-Leveling Mechanism	
Forward	26 deg.
Side to Side	14 deg.
Rearward	7 deg.

While general information, pictures, and descriptions are provided, some illustrations and text may include product options and accessories NOT AVAILABLE in all regions, and in some countries products and accessories may require modifications or additions to ensure compliance with the local regulations of those countries.

Contact us to learn more.

[JohnDeere.com/TrackedHarvesters](https://JohnDeere.com/TrackedHarvesters)

[JohnDeere.ca/TrackedHarvesters](https://JohnDeere.ca/TrackedHarvesters)



MTH859U (22-07)



**JOHN DEERE**