



# 644G

## LOADER



Model shown may include options

**SAE Net  
Horsepower**

170 hp  
(127 kW)

**Buckets  
Range to**

4.25 cu. yd.  
(3.2 m<sup>3</sup>)

**Operating  
Weights to**

35,357 lb.  
(16 035 kg)

ENGINE	544G	624G	644G
Type.....	John Deere 6059T with altitude-compensating turbocharger	John Deere 6068T with altitude-compensating turbocharger	John Deere 6076A with altitude-compensating turbocharger; aftercooled
Rated power .....	120 SAE net hp (90 kW) 125 SAE gross hp (94 kW) @ 2,200 rpm	145 SAE net hp (108 kW) 150 SAE gross hp (112 kW) @ 2,200 rpm	170 SAE net hp (127 kW) 178 SAE gross hp (133 kW) @ 2,200 rpm
Cylinders.....	6	6	6
Displacement .....	359 cu. in. (5.884 L)	414 cu. in. (6.785 L)	466 cu. in. (7.636 L)
Maximum net torque.....	388 lb.-ft. (527 Nm) @ 1,400 rpm	456 lb.-ft. (618 Nm) @ 1,300 rpm	598 lb.-ft. (811 Nm) @ 1,300 rpm
Lubrication.....	pressure system with full-flow spin-on filter and cooler	pressure system with full-flow spin-on filter and cooler	pressure system with full-flow spin-on filter and cooler
Fuel consumption, typical .....	2.0 to 4.0 gal./hr. (7.6 to 15.2 L/h)	2.6 to 4.8 gal./hr. (9.8 to 18.2 L/h)	3.0 to 5.9 gal./hr. (11.3 to 22.3 L/h)
Cooling fan .....	blower	blower	blower
Electrical system.....	12 volt with 95-amp alternator	12 volt with 95-amp alternator	12 volt with 95-amp alternator
Battery (one 12 volt) .....	reserve capacity: 160 min., 625 CCA	reserve capacity: 160 min., 625 CCA	reserve capacity: 160 min., 925 CCA
Air cleaner .....	dual safety element dry type; restriction indicator for service	dual safety element dry type; restriction indicator for service	dual safety element dry type; restriction indicator for service

TRANSMISSION	544G		624G		644G	
Type.....	torque converter – power shift		torque converter – power shift		torque converter – power shift	
Controls .....	low-effort electronically controlled automatic shift and quick-shift button		low-effort electronically controlled automatic shift and quick-shift button		low-effort electronically controlled automatic shift and quick-shift button	
	<i>Forward</i>	<i>Reverse</i>	<i>Forward</i>	<i>Reverse</i>	<i>Forward</i>	<i>Reverse</i>
Travel speeds* .....	<i>mph (km/h)</i>	<i>mph (km/h)</i>	<i>mph (km/h)</i>	<i>mph (km/h)</i>	<i>mph (km/h)</i>	<i>mph (km/h)</i>
Gear 1 .....	4.6 (7.4)	4.6 (7.4)	4.5 (7.3)	4.5 (7.3)	4.4 (7.0)	4.4 (7.0)
Gear 2 .....	7.7 (12.3)	7.7 (12.3)	7.2 (11.6)	7.2 (11.6)	7.0 (11.2)	7.0 (11.2)
Gear 3 .....	16.9 (27.2)	16.9 (27.2)	15.2 (24.5)	15.2 (24.5)	13.7 (22.0)	13.7 (22.0)
Gear 4 .....	23.8 (38.4)		23.0 (37.3)		21.5 (34.6)	

\*544G and 624G are equipped with 20.5-25 tires; 644G is equipped with 23.5-25 tires.

AXLES/BRAKES	544G	624G	644G
Final drives.....	heavy-duty planetary, mounted inboard	heavy-duty planetary, mounted inboard	heavy-duty planetary, mounted inboard
Differentials (choice of) .....	conventional front and rear – Standard; hydraulic lock front, conventional rear – Optional; NoSPIN front, conventional rear – Optional; hydraulic lock front and rear – Optional; front axle disconnect – Optional	conventional front and rear – Standard; hydraulic lock front, conventional rear – Optional; NoSPIN front, conventional rear – Optional; hydraulic lock front and rear – Optional; front axle disconnect – Optional	conventional front and rear – Standard; hydraulic lock front, conventional rear – Optional; NoSPIN front, conventional rear – Optional; hydraulic lock front and rear – Optional; front axle disconnect – Optional
Rear axle oscillation .....	22 degrees, stop to stop	26 degrees, stop to stop	26 degrees, stop to stop
Maximum rise and fall, single wheel.....	28.6 in. (727 mm)	32.8 in. (833 mm)	36.6 in. (929 mm)
Brakes (conform to SAE J1473, ISO3450)			
Service brakes .....	inboard-mounted hydraulic wet disc, bathed in cooling oil, long life self-adjusting	inboard-mounted hydraulic wet disc, bathed in cooling oil, long life self-adjusting	inboard-mounted hydraulic wet disc, bathed in cooling oil, long life self-adjusting
Parking brake.....	automatically spring applied, hydraulically released, disc and caliper type, attached to transmission output shaft	automatically spring applied, hydraulically released, disc and caliper type, attached to transmission output shaft	automatically spring applied, hydraulically released, disc and caliper type, attached to transmission output shaft

HYDRAULIC SYSTEM/STEERING	544G	624G	644G
Pump (loader and steering).....	gear-type, open-center system	gear-type, open-center system	gear-type, open-center system
Maximum flow.....	46.3 gpm (175 L/min.) @ 600 psi (4137 kPa) and 2,200 rpm	61 gpm (231 L/min.) @ 600 psi (4137 kPa) and 2,200 rpm	69.5 gpm (263 L/min.) @ 600 psi (4137 kPa) and 2,200 rpm
Pressure.....	loader relief 2,750 psi (18 961 kPa) steering relief 2,650 psi (18 270 kPa)	loader relief 2,800 psi (19 306 kPa) steering relief 2,650 psi (18 270 kPa)	loader relief 3,000 psi (20 685 kPa) steering relief 2,650 psi (18 270 kPa)
Loader controls .....	two-function valve with single lever and control lever lockout	two-function valve with single lever and control lever lockout	two-function valve with single lever and control lever lockout
Hydraulic cycle times			
Raise .....	5.8 sec.	5.8 sec.	6.2 sec.
Dump.....	1.4 sec.	1.7 sec.	1.8 sec.
Lower .....	3.2 sec. (float down) / 3.5 sec. (power down)	3.5 sec. (float down) / 3.5 sec. (power down)	3.5 sec. (float down) / 3.9 sec. (power down)
Maximum lift capacity.....	with 2.25 cu. yd. (1.7 m <sup>3</sup> ) excavating bucket	with 2.63 cu. yd. (2.0 m <sup>3</sup> ) excavating bucket	with 3.25 cu. yd. (2.5 m <sup>3</sup> ) excavating bucket
Lift at ground level .....	24,264 lb. (11 006 kg)	26,938 lb. (12 217 kg)	33,886 lb. (15 368 kg)
With coupler.....	23,302 lb. (10 568 kg)	25,589 lb. (11 605 kg)	32,524 lb. (14 750 kg)
Lift at maximum height.....	12,031 lb. (5457 kg)	14,143 lb. (6414 kg)	19,823 lb. (8990 kg)
With coupler.....	11,492 lb. (5212 kg)	13,817 lb. (6266 kg)	19,020 lb. (8626 kg)
Steering (conforms to SAE J1511)			
Type .....	power, fully hydraulic	power, fully hydraulic	power, fully hydraulic
Relief valve setting .....	2,650 psi (18 270 kPa)	2,650 psi (18 270 kPa)	2,650 psi (18 270 kPa)
Articulation angle.....	80-degree arc (40 degrees each direction)	80-degree arc (40 degrees each direction)	80-degree arc (40 degrees each direction)
Turning radius (measured to centerline of outside tire).....	16 ft. 3 in. (4.95 m)	16 ft. 10.5 in. (5.14 m)	17 ft. 11 in. (5.46 m)

TIRES	544G	624G	644G
Choice of.....	15.5-25, 12 PR L2 / 17.5-25, 12 PR L2 / 17.5-25, 12 PR L3 / 20.5-25, 12 PR L2 / 20.5-25, 12 PR L3 / 20.5-25, 16 PR L3 / 17.5-25, Radial, One Star L2 equivalent / 17.5-25, Radial, One Star L3 equivalent / 20.5-25, Radial, One Star L2 equivalent / 20.5-25, Radial, One Star L3 equivalent	17.5-25, 12 PR L2 / 17.5-25, 12 PR L3 / 20.5-25, 12 PR L2 / 20.5-25, 12 PR L3 / 20.5-25, 16 PR L3 / 17.5-25, Radial, One Star L2 equivalent / 17.5-25, Radial, One Star L3 equivalent / 20.5-25, Radial, One Star L2 equivalent / 20.5-25, Radial, One Star L3 equivalent	20.5-25, 12 PR L2 / 20.5-25, 16 PR L2 / 20.5-25, 16 PR L3 / 23.5-25, 12 PR L2 / 23.5-25, 16 PR L3 / 23.5-25, 20 PR L3 / 20.5-25, Radial, One Star L3 equivalent / 20.5-25, Radial, One Star L2 equivalent / 23.5-25, Radial, One Star L3 equivalent
15.5-25 tires (one- or three-piece wheels)			
Tread width .....	76.38 in. (1940 mm)		
Width over tires.....	93.11 in. (2365 mm)		
Change in vertical height.....	- 1.57 in. (- 40 mm)		
17.5-25 tires			
Tread width .....	76.38 in. (1940 mm)	81.1 in. (2060 mm)	
Width over tires.....	95.28 in. (2420 mm)	100.3 in. (2549 mm)	
Change in vertical height.....	0	- 2.36 in. (- 60 mm)	

# SPECIFICATIONS / DIMENSIONS

## TIRES (continued)

	544G	624G	644G
20.5-25 tires			
Tread width .....	74.80 in. (1900 mm)	77.2 in. (1960 mm)	85.4 in. (2170 mm)
Width over tires .....	96.93 in. (2462 mm)	99.3 in. (2522 mm)	107.6 in. (2732 mm)
Change in vertical height .....	+ 2.60 in. (+ 66 mm)	0	- 2.0 in. (- 51 mm)
20.5-25, Radial tires			
Tread width .....			85.4 in. (2170 mm)
Width over tires .....			108.0 in. (2743 mm)
Change in vertical height .....			- 2.4 in. (- 62 mm)
23.5-25 tires			
Tread width .....			83.5 in. (2120 mm)
Width over tires .....			108.9 in. (2765 mm)
Change in vertical height .....			0

## CAPACITIES (U.S.)

Fuel tank with ground level fueling .....	57.6 gal. (218 L)	65.7 gal. (249 L)	75 gal. (284 L)
Cooling system .....	25 qt. (24 L)	26 qt. (25 L)	30 qt. (28.5 L)
Engine lubrication, including full-flow spin-on filter .....	20 qt. (19 L)	20 qt. (19 L)	25 qt. (24 L)
Power shift transmission, including vertical cartridge filter .....	10 qt. (9.5 L)	12 qt. (11 L)	15 qt. (14 L)
Differentials			
Front .....	20 qt. (19 L)	30 qt. (28 L)	30 qt. (28.4 L)
Rear .....	20 qt. (19 L)	20 qt. (19 L)	30 qt. (28.4 L)
Loader hydraulic reservoir .....	80 qt. (76 L)	108 qt. (102 L)	120 qt. (115 L)

## DIMENSIONS WITH BUCKET

<b>A</b> Overall height .....	11 ft. 5.3 in. (3.52 m)	11 ft. 10.4 in. (3.62 m)	12 ft. 3.2 in. (3.74 m)
<b>B</b> Height to top of cab and canopy .....	10 ft. 4.8 in. (3.17 m)	10 ft. 9.9 in. (3.30 m)	11 ft. 2.7 in. (3.42 m)
<b>C</b> Height to top of exhaust .....	9 ft. 2 in. (2.79 m)	9 ft. 7.9 in. (2.94 m)	10 ft. 4.4 in. (3.16 m)
<b>D</b> Ground clearance .....	14.7 in. (373 mm)	17 in. (433 mm)	19 in. (483 mm)
<b>E</b> Length from centerline of front axle .....	57 in. (1450 mm)	59.65 in. (1515 mm)	63 in. (1600 mm)
<b>F</b> Wheelbase .....	114 in. (2900 mm)	119.3 in. (3030 mm)	126 in. (3200 mm)
<b>G</b> Maximum bucket angle .....	55.3 degrees	55.8 degrees	55 degrees
<b>H</b> Dump height .....	▲	▲	▲
<b>I</b> Height to hinge pin, fully raised .....	12 ft. 2.6 in. (3.72 m)	12 ft. 9.3 in. (3.89 m)	13 ft. 1.9 in. (4.0 m)
<b>J</b> Digging depth .....	4 in. (101 mm)	2 in. (52 mm)	2.68 in. (68 mm)

▲ See Bucket Information below and on page 18.

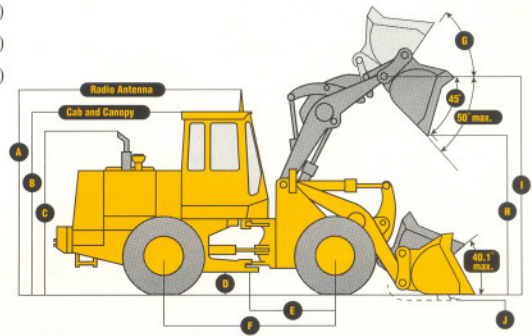

## 544G BUCKET INFORMATION (PIN-ON)

Bucket Type/Size	Stockpiling w/ Bolt-on Edge	Stockpiling w/ Bolt-on Edge	Stockpiling w/ Spillguard*	Stockpiling w/ Bolt-on Edge + Spillguard*	Excavating w/ Bolt-on Edge	Excavating w/ Bolt-on Edge	Excavating w/ Spillguard*	Excavating w/ Bolt-on Edge + Spillguard*	Multi- purpose**
Capacity, heaped SAE, in cu. yd. (m <sup>3</sup> ) .....	2.63 (2.0)	2.5 (1.9)	2.75 (2.1)	2.88 (2.2)	2.38 (1.8)	2.25 (1.7)	2.5 (1.9)	2.63 (2.0)	2.13 (1.6)
Capacity, struck SAE, in cu. yd. (m <sup>3</sup> ) .....	2.25 (1.7)	2.12 (1.62)	2.41 (1.84)	2.51 (1.92)	1.99 (1.52)	1.88 (1.44)	2.16 (1.65)	2.26 (1.73)	1.77 (1.35)
Bucket width, in in. (m) .....	100.4 (2.55)	100.4 (2.55)	100.4 (2.55)	100.4 (2.55)	100.4 (2.55)	100.4 (2.55)	100.4 (2.55)	100.4 (2.55)	100.4 (2.55)
Breakout force, SAE J732C, in lb. (kN) .....	20,569 (91.5)	22,207 (98.8)	22,110 (98.4)	20,430 (90.9)	22,145 (98.5)	24,030 (106.9)	23,942 (106.5)	22,059 (98.1)	20,682 (93.8)
Tipping load, straight, in lb. (kg) .....	18,914 (8579)	19,469 (8831)	19,423 (8810)	18,841 (8546)	19,262 (8737)	19,833 (8966)	19,791 (8977)	19,132 (8678)	17,556 (7963)
Tipping load, 40-degree full turn, SAE, in lb. (kg) .....	16,008 (7261)	16,534 (7500)	16,484 (7477)	15,933 (7227)	16,334 (7409)	16,876 (7655)	16,830 (7634)	16,202 (7349)	14,806 (6716)
Reach, 45-degree dump, 7-ft. (2.13 m) clearance, in in. (mm) .....	58.15 (1477)	58.03 (1474)	58.03 (1474)	58.15 (1477)	57.2 (1453)	57.05 (1449)	57.05 (1449)	57.2 (1453)	50.3 (1277)
Reach, 45-degree dump, full height, in in. (mm) .....	40.6 (1030)	39.2 (995)	39.2 (995)	40.6 (1030)	38.6 (980)	37.2 (944)	37.2 (944)	38.6 (980)	34.7 (881)
▲ Dump clearance, 45 degree, full height, in in. (mm) .....	107.2 (2724)	109.8 (2788)	109.8 (2788)	107.2 (2724)	109.3 (2776)	111.8 (2839)	111.8 (2839)	109.3 (2776)	103.8 (2636)
Overall length, in ft.-in. (m) .....	23-1.8 (7.06)	22-10.2 (6.97)	22-10.2 (6.97)	23-1.8 (7.06)	22-10.1 (6.96)	22-7.2 (6.89)	22-7.2 (6.89)	22-10.7 (6.98)	23-2.8 (7.08)
Loader clearance circle, bucket in carry position, in ft.-in. (m) .....	37-9 (11.51)	37-7 (11.46)	37-7 (11.46)	37-9 (11.51)	27-7.4 (11.47)	37-5 (11.44)	37-5 (11.44)	37-7.4 (11.47)	37-10 (11.54)
Operating weight, in lb. (kg) .....	24,092 (10 928)	23,828 (10 808)	23,947 (10 662)	24,311 (11 027)	23,934 (10 856)	23,570 (10 691)	23,689 (10 745)	24,053 (10 910)	24,601 (11 158)

\*Auxiliary spillguard is dealer installed. The spillguard is primarily intended to prevent spillage of loose material. However, it does increase bucket capacity.

\*\*Allied attachments ordered through John Deere dealers.

Loader operating information is based on machine with all standard equipment; 17.5-25, 12 PR L2 tires; two rear counterweights; ROPS cab; 175-lb. (79 kg) operator; and full fuel tank. This information is affected by tire size, ballast, and different attachments.

## 544G ADJUSTMENTS TO OPERATING WEIGHTS FOR PIN-ON BUCKETS

### Adjustments to operating weights and tipping loads for 2.25 cu. yd. (1.7 m<sup>3</sup>) excavating bucket

Add (+) or deduct (-) lb. (kg) as indicated for

loaders with	Operating Weight	Tipping Load, Straight	Tipping Load, 40-Degree Full Turn, SAE
15.5-25, 12 PR L2 tires without CaCl <sub>2</sub> .....	- 194 lb. (- 88 kg)	- 137 lb. (- 62 kg)	- 119 lb. (- 54 kg)
15.5-25, 12 PR L2 tires with CaCl <sub>2</sub> .....	+ 756 lb. (+ 343 kg)	+ 1,199 lb. (+ 544 kg)	+ 1,036 lb. (+ 470 kg)
17.5-25, 12 PR L2 tires with CaCl <sub>2</sub> .....	+ 1,180 lb. (+ 535 kg)	+ 1,658 lb. (+ 752 kg)	+ 1,431 lb. (+ 649 kg)
17.5-25, 12 PR L3 tires without CaCl <sub>2</sub> .....	+ 132 lb. (+ 60 kg)	+ 93 lb. (+ 42 kg)	+ 79 lb. (+ 36 kg)
17.5-25, 12 PR L3 tires with CaCl <sub>2</sub> .....	+ 1,312 lb. (+ 595 kg)	+ 1,750 lb. (+ 794 kg)	+ 1,512 lb. (+ 686 kg)
17.5-25, Radial, One Star L2 equivalent tires without CaCl <sub>2</sub> .....	+ 379 lb. (+ 172 kg)	+ 267 lb. (+ 121 kg)	+ 229 lb. (+ 104 kg)
17.5-25, Radial, One Star L2 equivalent tires with CaCl <sub>2</sub> .....	+ 1,559 lb. (+ 707 kg)	+ 1,925 lb. (+ 873 kg)	+ 1,662 lb. (+ 754 kg)
20.5-25, 12 PR L2 tires without CaCl <sub>2</sub> .....	+ 794 lb. (+ 360 kg)	+ 558 lb. (+ 253 kg)	+ 481 lb. (+ 218 kg)
20.5-25, 12 PR L2 tires with CaCl <sub>2</sub> .....	+ 2,615 lb. (+ 1186 kg)	+ 3,117 lb. (+ 1414 kg)	+ 2,692 lb. (+ 1221 kg)
20.5-25, 12 PR L3 tires without CaCl <sub>2</sub> .....	+ 1,085 lb. (+ 442 kg)	+ 763 lb. (+ 346 kg)	+ 657 lb. (+ 298 kg)
20.5-25, 12 PR L3 tires with CaCl <sub>2</sub> .....	+ 2,906 lb. (+ 1318 kg)	+ 3,323 lb. (+ 1507 kg)	+ 2,869 lb. (+ 1301 kg)
ROPS canopy in lieu of ROPS cab .....	- 320 lb. (- 145 kg)	- 302 lb. (- 137 kg)	- 278 lb. (- 126 kg)
Bucket teeth .....	+ 240 lb. (+ 109 kg)	- 295 lb. (- 134 kg)	- 289 lb. (- 131 kg)
Deduct two rear counterweights .....	- 1,736 lb. (- 787 kg)	- 3,978 lb. (- 1804 kg)	- 3,188 lb. (- 1446 kg)
Add one rear counterweight* .....	- 946 lb. (- 429 kg)	- 2,130 lb. (- 966 kg)	- 1,748 lb. (- 793 kg)

\*Optional counterweight not to be used when CaCl<sub>2</sub> ballast is used in the tires.

## 624G BUCKET INFORMATION (PIN-ON)

Bucket Type/Size	Stockpiling w/ Bolt-on Edge	Stockpiling w/o Bolt-on Edge	Stockpiling w/ Spillguard*	Stockpiling w/ Bolt-on Edge + Spillguard*	Excavating w/ Bolt-on Edge	Excavating w/o Bolt-on Edge	Excavating w/ Spillguard*	Excavating w/ Bolt-on Edge + Spillguard*	Multi- purpose**
Capacity, heaped SAE, in cu. yd. (m <sup>3</sup> )	3.25 (2.5)	3.0 (2.3)	3.12 (2.4)	3.38 (2.6)	2.75 (2.1)	2.63 (2.0)	2.75 (2.1)	3.0 (2.3)	2.38 (1.8)
Capacity, struck SAE, in cu. yd. (m <sup>3</sup> )	2.75 (2.1)	2.63 (2.0)	2.88 (2.2)	3.0 (2.3)	2.38 (1.8)	2.25 (1.7)	2.5 (1.9)	2.63 (2.0)	2.0 (1.5)
Bucket width, in. (m)	101.8 (2.58)	101.8 (2.58)	101.8 (2.58)	101.8 (2.58)	101.8 (2.58)	101.8 (2.58)	101.8 (2.58)	101.8 (2.58)	101.8 (2.58)
Breakout force, SAE J732C, in lb. (kN)	26,708 (118.8)	29,404 (130.8)	29,238 (130.0)	26,494 (117.8)	29,047 (129.2)	32,202 (143.2)	32,109 (142.8)	28,925 (128.6)	32,471 (144.4)
Tipping load, straight, in lb. (kg)	20,484 (9290)	21,205 (9617)	21,157 (9595)	20,401 (9252)	20,758 (9414)	21,497 (9749)	21,459 (9732)	20,707 (9391)	20,013 (9079)
Tipping load, 40-degree full turn, SAE, in lb. (kg)	17,329 (7859)	18,001 (8164)	17,951 (8141)	17,241 (7819)	17,572 (7969)	18,262 (8282)	18,220 (8263)	17,514 (7943)	16,908 (7668)
Reach, 45-degree dump, 7-ft. (2.13 m) clearance, in. (mm)	60.5 (1536)	59.8 (1520)	59.8 (1520)	60.5 (1536)	59.2 (1503)	58.5 (1485)	58.5 (1485)	59.2 (1503)	49.8 (1265)
Reach, 45-degree dump, full height, in. (mm)	40.4 (1027)	38.0 (966)	38.0 (966)	40.4 (1027)	37.6 (956)	35.3 (896)	35.3 (896)	37.6 (956)	28.6 (726)
▲ Dump clearance, 45 degree, full height, in. (mm)	109.6 (2784)	112.9 (2868)	112.9 (2868)	109.6 (2784)	112.4 (2854)	115.7 (2938)	115.7 (2938)	112.4 (2854)	111.8 (2839)
Overall length, in ft.-in. (m)	24-8.3 (7.52)	24-3.7 (7.41)	24-3.7 (7.41)	24-8.3 (7.52)	24-4.2 (7.42)	23-11.5 (7.3)	23-11.5 (7.3)	24-4.2 (7.42)	24-0.9 (7.34)
Loader clearance circle, bucket in carry position, in ft.-in. (m)	39-5.6 (12.03)	39-2.8 (11.96)	39-2.8 (11.96)	39-5.6 (12.03)	39-3.2 (11.97)	39-0 (11.9)	39-0 (11.9)	39-3.2 (11.97)	39-1.7 (11.93)
Operating weight, in lb. (kg)	27,854 (12 632)	27,435 (12 442)	27,554 (12 496)	27,973 (12 686)	27,756 (12 588)	27,338 (12 398)	27,456 (12 452)	27,876 (12 642)	28,103 (12 745)

\*Auxiliary spillguard is dealer installed. The spillguard is primarily intended to prevent spillage of loose material. However, it does increase bucket capacity.

\*\*Allied attachments ordered through John Deere dealers.

Loader operating information is based on machine with all standard equipment; 20.5-25, 12 PR L2 tires; one rear counterweight; ROPS cab; 175-lb. (79 kg) operator; and full fuel tank. This information is affected by tire size, ballast, and different attachments.

## 624G ADJUSTMENTS TO OPERATING WEIGHTS FOR PIN-ON BUCKETS

### Adjustments to operating weights and tipping loads for 2.63 cu. yd. (2.0 m<sup>3</sup>) excavating bucket

Add (+) or deduct (-) lb. (kg) as indicated for

loaders with

	Operating Weight
17.5-25, 12 PR L2 tires without CaCl <sub>2</sub>	- 794 lb. (- 360 kg)
17.5-25, 12 PR L2 tires with CaCl <sub>2</sub>	+ 386 lb. (+ 175 kg)
17.5-25, 12 PR L3 tires without CaCl <sub>2</sub>	- 661 lb. (- 300 kg)
17.5-25, 12 PR L3 tires with CaCl <sub>2</sub>	+ 518 lb. (+ 235 kg)
17.5-25, Radial, One Star L2 equivalent tires without CaCl <sub>2</sub>	- 414 lb. (- 188 kg)
17.5-25, Radial, One Star L2 equivalent tires with CaCl <sub>2</sub>	+ 765 lb. (+ 347 kg)
20.5-25, 12 PR L2 tires with CaCl <sub>2</sub>	+ 1,820 lb. (+ 826 kg)
20.5-25, 12 PR L3 tires without CaCl <sub>2</sub>	+ 291 lb. (+ 132 kg)
20.5-25, 12 PR L3 tires with CaCl <sub>2</sub>	+ 2,112 lb. (+ 958 kg)
20.5-25, Radial, One Star L2 equivalent tires without CaCl <sub>2</sub>	+ 467 lb. (+ 212 kg)
20.5-25, Radial, One Star L2 equivalent tires with CaCl <sub>2</sub>	+ 2,288 lb. (+ 1038 kg)
ROPS canopy in lieu of ROPS cab	- 320 lb. (- 145 kg)
Bucket teeth	+ 240 lb. (+ 109 kg)
Deduct one rear counterweight	- 946 lb. (- 429 kg)
Add second rear counterweight*	+ 1,169 lb. (+ 530 kg)

\*Optional counterweight not to be used when CaCl<sub>2</sub> ballast is used in the tires.

Tipping Load, Straight

- 560 lb. (- 254 kg)
+ 1,100 lb. (+ 499 kg)
- 467 lb. (- 212 kg)
+ 1,193 lb. (+ 541 kg)
- 293 lb. (- 133 kg)
+ 1,367 lb. (+ 620 kg)
+ 2,560 lb. (+ 1161 kg)
+ 205 lb. (+ 93 kg)
+ 2,765 lb. (+ 1254 kg)
+ 331 lb. (+ 150 kg)
+ 2,888 lb. (+ 1310 kg)
- 299 lb. (- 136 kg)
- 298 lb. (- 135 kg)
- 2,134 lb. (- 968 kg)
+ 2,677 lb. (+ 1214 kg)

Tipping Load, 40-

Degree Full Turn, SAE

- 483 lb. (- 219 kg)
+ 950 lb. (+ 431 kg)
- 403 lb. (- 183 kg)
+ 1,030 lb. (+ 467 kg)
- 251 lb. (- 114 kg)
+ 1,179 lb. (+ 535 kg)
+ 2,211 lb. (+ 1003 kg)
+ 179 lb. (+ 81 kg)
+ 2,388 lb. (+ 1083 kg)
+ 287 lb. (+ 130 kg)
+ 2,493 lb. (+ 1131 kg)
- 241 lb. (- 109 kg)
- 291 lb. (- 132 kg)
- 1,753 lb. (- 795 kg)
+ 2,196 lb. (+ 996 kg)

## 644G BUCKET INFORMATION (PIN-ON)

Bucket Type/Size	Stockpiling w/ Bolt-on Edge	Stockpiling w/o Bolt-on Edge	Stockpiling w/ Spillguard*	Stockpiling w/ Bolt-on Edge + Spillguard*	Excavating w/ Bolt-on Edge	Excavating w/o Bolt-on Edge	Excavating w/ Spillguard*	Excavating w/ Bolt-on Edge + Spillguard*	Multi- purpose**
Capacity, heaped SAE, in cu. yd. (m <sup>3</sup> )	4.0 (3.1)	3.75 (2.9)	4.0 (3.1)	4.25 (3.2)	3.5 (2.7)	3.25 (2.5)	3.5 (2.7)	3.75 (2.8)	2.75 (2.1)
Capacity, struck SAE, in cu. yd. (m <sup>3</sup> )	3.4 (2.6)	3.2 (2.45)	3.57 (2.73)	3.78 (2.89)	2.88 (2.2)	2.75 (2.1)	3.14 (2.4)	3.25 (2.5)	2.31 (1.77)
Bucket width, in. (m)	112.2 (2.85)	112.2 (2.85)	112.2 (2.85)	112.2 (2.85)	112.2 (2.85)	112.2 (2.85)	112.2 (2.85)	112.2 (2.85)	112.2 (2.85)
Breakout force, SAE J732C, in lb. (kN)	34,171 (152.0)	37,440 (166.5)	37,346 (166.1)	33,997 (151.2)	37,284 (165.8)	41,105 (182.8)	41,012 (182.4)	37,139 (165.2)	41,720 (185.6)
Tipping load, straight, in lb. (kg)	26,264 (11 911)	27,329 (12 394)	27,298 (12 380)	26,184 (11 875)	26,883 (12 192)	27,734 (12 578)	27,708 (12 566)	26,844 (12 174)	26,731 (12 123)
Tipping load, 40-degree full turn, SAE, in lb. (kg)	22,118 (10 031)	23,161 (10 504)	23,124 (10 487)	22,032 (9992)	22,730 (10 310)	23,525 (10 669)	23,492 (10 654)	22,687 (10 289)	22,614 (10 256)
Tipping load, 35-degree turn, SAE, in lb. (kg)	22,932 (10 400)	23,975 (10 873)	23,937 (10 856)	22,846 (10 361)	23,543 (10 677)	24,345 (11 041)	24,314 (11 027)	23,499 (10 657)	23,417 (10 620)
Reach, 45-degree dump, 7-ft. (2.13 m) clearance, in. (mm)	64.4 (1635)	63.8 (1622)	63.8 (1622)	64.4 (1635)	62.8 (1596)	62.2 (1580)	62.2 (1580)	62.8 (1596)	57.1 (1450)
Reach, 45-degree dump, full height, in. (mm)	45.0 (1142)	42.7 (1086)	42.7 (1086)	45.0 (1142)	42.0 (1068)	39.8 (1011)	39.8 (1011)	42.0 (1068)	35.6 (904)
▲ Dump clearance, 45 degree, full height, in. (mm)	111.3 (2828)	114.8 (2917)	114.8 (2917)	111.3 (2828)	114.3 (2904)	117.8 (2992)	117.8 (2993)	114.3 (2904)	115.8 (2942)
Overall length, in ft.-in. (m)	25-10.4 (7.88)	25-5.5 (7.76)	25-5.5 (7.76)	25-10.4 (7.88)	25-5.9 (7.77)	25-1 (7.65)	25-1 (7.65)	25-5.9 (7.77)	25-0.5 (7.63)
Loader clearance circle, bucket in carry position, in ft.-in. (m)	42-0.2 (12.81)	41-9.2 (12.73)	41-9.2 (12.73)	42-0.2 (12.81)	41-9.6 (12.74)	41-6.7 (12.67)	41-6.7 (12.67)	41-9.6 (12.74)	41-6.3 (12.66)
Operating weight, in lb. (kg)	35,236 (15 980)	34,824 (15 793)	34,943 (15 847)	35,357 (16 035)	34,980 (15 864)	34,544 (15 666)	32,226 (15 720)	35,095 (15 916)	35,035 (15 889)

\*Auxiliary spillguard is dealer installed. The spillguard is primarily intended to prevent spillage of loose material. However, it does increase bucket capacity.

\*\*Allied attachments ordered through John Deere dealers.

Loader operating information is based on machine with all standard equipment; 23.5-25, 12 PR L2 tires; one rear counterweight; ROPS cab; 175-lb. (79 kg) operator; and full fuel tank. This information is affected by tire size, ballast, and different attachments.

## 644G ADJUSTMENTS TO OPERATING WEIGHTS FOR PIN-ON BUCKETS

### Adjustments to operating weights and tipping loads for 3.25 cu. yd. (2.5 m<sup>3</sup>) excavating bucket

Add (+) or deduct (-) lb. (kg) as indicated for

loaders with

	Operating Weight
20.5-25, 12 PR L2 tires without CaCl <sub>2</sub>	- 1,587 lb. (- 720 kg)
20.5-25, 12 PR L2 tires with CaCl <sub>2</sub>	+ 234 lb. (+ 106 kg)
20.5-25, 16 PR L2 tires without CaCl <sub>2</sub>	- 1,499 lb. (- 680 kg)
20.5-25, 16 PR L2 tires with CaCl <sub>2</sub>	+ 322 lb. (+ 146 kg)
20.5-25, 16 PR L3 tires without CaCl <sub>2</sub>	- 1,235 lb. (- 560 kg)
20.5-25, 16 PR L3 tires with CaCl <sub>2</sub>	+ 586 lb. (+ 266 kg)
20.5-25, Radial, One Star L2 equivalent tires without CaCl <sub>2</sub>	- 1,120 lb. (- 508 kg)
20.5-25, Radial, One Star L2 equivalent tires with CaCl <sub>2</sub>	+ 701 lb. (+ 318 kg)
23.5-25, 12 PR L2 tires with CaCl <sub>2</sub>	+ 2,396 lb. (+ 1087 kg)
23.5-25, 20 PR L3 tires without CaCl <sub>2</sub>	+ 494 lb. (+ 224 kg)
23.5-25, 20 PR L3 tires with CaCl <sub>2</sub>	+ 2,890 lb. (+ 1311 kg)
ROPS canopy in lieu of ROPS cab	- 320 lb. (- 145 kg)
Bucket teeth	+ 262 lb. (+ 119 kg)
Deduct one rear counterweight	- 910 lb. (- 413 kg)
Add second rear counterweight*	+ 1,422 lb. (+ 645 kg)

\*Optional counterweight not to be used when CaCl<sub>2</sub> ballast is used in the tires.

Tipping Load, Straight

- 1,129 lb. (- 512 kg)
+ 1,462 lb. (+ 663 kg)
- 1,067 lb. (- 484 kg)
+ 1,526 lb. (+ 692 kg)
- 877 lb. (- 398 kg)
+ 1,713 lb. (+ 777 kg)
- 796 lb. (- 361 kg)
+ 1,795 lb. (+ 814 kg)
+ 3,411 lb. (+ 1547 kg)
+ 353 lb. (+ 160 kg)
+ 3,761 lb. (+ 1706 kg)
- 295 lb. (- 134 kg)
- 326 lb. (- 148 kg)
- 2,068 lb. (- 938 kg)
+ 3,258 lb. (+ 1478 kg)

Tipping Load, 35-

Degree Turn, SAE

- 1,005 lb. (- 456 kg)
+ 1,301 lb. (+ 590 kg)
- 950 lb. (- 431 kg)
+ 1,356 lb. (+ 615 kg)
- 783 lb. (- 355 kg)
+ 1,523 lb. (+ 691 kg)
- 710 lb. (- 322 kg)
+ 1,596 lb. (+ 724 kg)
+ 3,036 lb. (+ 1,377 kg)
+ 313 lb. (+ 142 kg)
+ 3,347 lb. (+ 1518 kg)
- 273 lb. (- 124 kg)
- 322 lb. (- 146 kg)
- 1,773 lb. (- 804 kg)
+ 2,789 lb. (+ 1265 kg)

Tipping Load, 40-

Degree Full Turn, SAE

- 977 lb. (- 443 kg)
+ 1,263 lb. (+ 573 kg)
- 922 lb. (- 418 kg)
+ 1,316 lb. (+ 597 kg)
- 758 lb. (- 344 kg)
+ 1,479 lb. (+ 671 kg)
- 688 lb. (- 312 kg)
+ 1,550 lb. (+ 703 kg)
+ 2,945 lb. (+ 1336 kg)
+ 304 lb. (+ 138 kg)
+ 3,250 lb. (+ 1474 kg)
- 276 lb. (- 125 kg)
- 320 lb. (- 145 kg)
- 1,700 lb. (- 771 kg)
+ 2,672 lb. (+ 1212 kg)

544G / 624G / 644G BUCKET SELECTION GUIDE\*

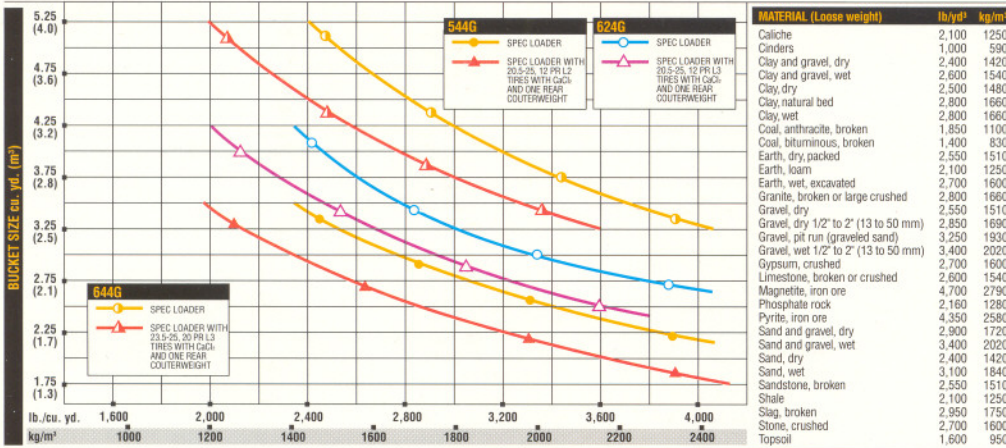

\*This guide, representing bucket sizes not necessarily manufactured by Deere, will help you in selecting proper bucket size for material density and loader configuration. Optimum bucket size is determined after adding or subtracting all the tipping load changes due to optional equipment.

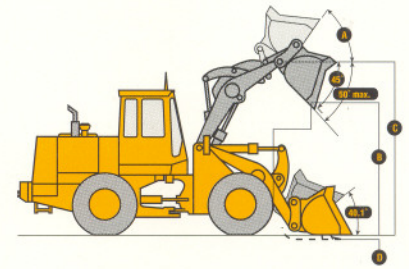

544G / 624G / 644G LOADER WITH TOOL CARRIER AND BUCKET\*

DIMENSIONS WITH TOOL CARRIER

544G

624G

644G

BUCKET

<b>A</b> Maximum bucket angle.....	55.3 degrees	55.8 degrees	55 degrees
<b>B</b> Dump height .....	▲	▲	▲
<b>C</b> Height to hinge pin, fully raised .....	12 ft. 2.6 in. (3.72 m)	12 ft. 9.3 in. (3.89 m)	13 ft. 1.9 in. (4.0 m)
<b>D</b> Digging depth.....	4 in. (101 mm)	2 in. (52 mm)	2.68 in. (68 mm)

PALLET FORK

<b>A</b> Reach, fully raised.....	2 ft. 3.4 in. (697 mm)	1 ft. 11.9 in. (607 mm)	2 ft. 6.3 in. (770 mm)
<b>B</b> Maximum reach, fork level .....	4 ft. 9.5 in. (1461 mm)	4 ft. 9.5 in. (1460 mm)	5 ft. 1.7 in. (1568 mm)
<b>C</b> Reach, ground level .....	2 ft. 11.9 in. (912 mm)	3 ft. 0.7 in. (932 mm)	3 ft. 1.7 in. (958 mm)
<b>D</b> Fork height, maximum reach.....	5 ft. 4.6 in. (1641 mm)	5 ft. 5.1 in. (1654 mm)	6 ft. 0.4 in. (1840 mm)
<b>E</b> Fork height, fully raised.....	11 ft. 4.7 in. (3473 mm)	11 ft. 0.6 in. (3623 mm)	12 ft. 6.3 in. (3818 mm)
<b>F</b> Digging depth.....	4 in. (101 mm)	3.7 in. (93 mm)	1.9 in. (48 mm)

MATERIAL-HANDLING ARM

<b>A</b> Reach, fully raised (extended) .....	11 ft. 3.7 in. (3446 mm)	11 ft. 0.6 in. (3368 mm)	11 ft. 6.9 in. (3527 mm)
<b>B</b> Reach, fully raised (mid-position) .....	9 ft. 5.8 in. (2890 mm)	9 ft. 2.7 in. (2812 mm)	9 ft. 8.3 in. (2953 mm)
<b>C</b> Reach, fully raised (retracted) .....	6 ft. 9 in. (2057 mm)	6 ft. 5.9 in. (1979 mm)	6 ft. 10.4 in. (2092 mm)
<b>D</b> Maximum reach (retracted).....	11 ft. 6.1 in. (3508 mm)	11 ft. 6.3 in. (3512 mm)	11 ft. 8.7 in. (3574 mm)
<b>E</b> Maximum reach (mid-position) .....	15 ft. 3.1 in. (4651 mm)	15 ft. 3.3 in. (4655 mm)	15 ft. 5.7 in. (4717 mm)
<b>F</b> Maximum reach (extended) .....	17 ft. 9.1 in. (5413 mm)	17 ft. 9.3 in. (5417 mm)	17 ft. 11.7 in. (5479 mm)
<b>G</b> Reach, below ground (retracted) .....	7 ft. 6.6 in. (2302 mm)	7 ft. 9.2 in. (2367 mm)	7 ft. 11.4 in. (2423 mm)
<b>H</b> Reach, below ground (mid-position).....	9 ft. 11.9 in. (3046 mm)	10 ft. 8.2 in. (3257 mm)	10 ft. 10.9 in. (3324 mm)
<b>I</b> Reach, below ground (extended).....	11 ft. 10 in. (3608 mm)	12 ft. 7.5 in. (3849 mm)	12 ft. 10.5 in. (3924 mm)
<b>J</b> Height, maximum reach.....	6 ft. 3.6 in. (1919 mm)	6 ft. 4.2 in. (1935 mm)	6 ft. 7.5 in. (2019 mm)
<b>K</b> Depth, below ground (retracted).....	4 ft. 10.9 in. (1496 mm)	4 ft. 4.1 in. (1323 mm)	4 ft. 2.3 in. (1294 mm)
<b>L</b> Depth, below ground (mid-position).....	7 ft. 5.3 in. (2286 mm)	6 ft. 8.3 in. (2040 mm)	6 ft. 6.7 in. (1998 mm)
<b>M</b> Depth, below ground (extended) .....	9 ft. 1.6 in. (2783 mm)	8 ft. 3.2 in. (2519 mm)	8 ft. 1.2 in. (2468 mm)
<b>N</b> Height, fully raised (extended).....	22 ft. 1.2 in. (6736 mm)	22 ft. 7.9 in. (6905 mm)	22 ft. 11 in. (6985 mm)
<b>O</b> Height, fully raised (mid-position).....	20 ft. 4.6 in. (6214 mm)	20 ft. 11.3 in. (6383 mm)	21 ft. 3.3 in. (6484 mm)
<b>P</b> Height, fully raised (retracted).....	17 ft. 9.9 in. (5432 mm)	18 ft. 4.5 in. (5600 mm)	18 ft. 9.7 in. (5732 mm)

▲ See Bucket Information below and on pages 20-21.

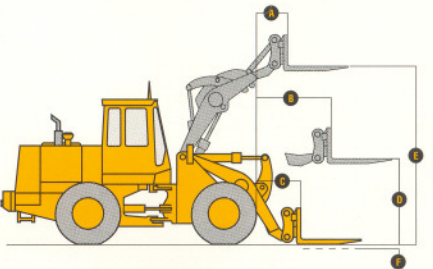

544G / 624G / 644G LOADER WITH TOOL CARRIER AND PALLET FORK\*

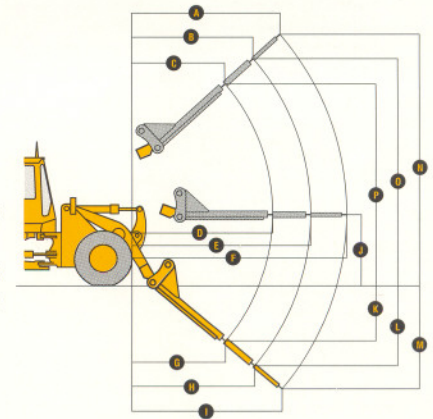

544G / 624G / 644G LOADER WITH TOOL CARRIER AND MATERIAL-HANDLING ARM\*

\*Allied attachments ordered through John Deere dealers.

544G TOOL CARRIER INFORMATION (COUPLER AND BUCKET)

Bucket Type/Size	General Purpose*	General Purpose*	General Purpose*	General Purpose*
Capacity, heaped SAE.....	2.63 cu. yd. (2.0 m³)	2.25 cu. yd. (1.7 m³)	2.0 cu. yd. (1.5 m³)	1.75 cu. yd. (1.4 m³)
Capacity, struck SAE.....	2.25 cu. yd. (1.7 m³)	1.88 cu. yd. (1.44 m³)	1.9 cu. yd. (1.45 m³)	1.5 cu. yd. (1.15 m³)
Bucket width .....	101.8 in. (2.59 m)	100.4 in. (2.55 m)	95.25 in. (2.42 m)	95.25 in. (2.42 m)
Breakout force, SAE J732C.....	20,342 lb. (90.5 kN)	22,407 lb. (99.7 kN)	25,223 lb. (114.4 kN)	27,166 lb. (120.8 kN)
Tipping load, straight.....	18,453 lb. (8370 kg)	19,002 lb. (8619 kg)	19,196 lb. (8707 kg)	19,342 lb. (8773 kg)
Tipping load, 40-degree full turn, SAE.....	15,607 lb. (7079 kg)	16,110 lb. (7307 kg)	16,286 lb. (7387 kg)	16,417 lb. (7446 kg)
Reach, 45-degree dump, 7-ft. (2.13 m) clearance .....	58.5 in. (1486 mm)	58.1 in. (1477 mm)	51.9 in. (1319 mm)	51.9 in. (1319 mm)
Reach, 45-degree dump, full height.....	41.1 in. (1044 mm)	39.1 in. (992 mm)	31.77 in. (807 mm)	31.77 in. (807 mm)
▲ Dump clearance, 45 degree, full height.....	107 in. (2717 mm)	110.1 in. (2798 mm)	112.4 in. (2854 mm)	112.4 in. (2854 mm)
Overall length.....	23 ft. 2 in. (7.06 m)	22 ft. 4.8 in. (6.83 m)	22 ft. 4.8 in. (6.83 m)	22 ft. 4.8 in. (6.83 m)
Loader clearance circle, bucket in carry position .....	37 ft. 10.6 in. (11.55 m)	37 ft. 6.7 in. (11.45 m)	37 ft. 0 in. (11.28 m)	37 ft. 0 in. (11.28 m)
Operating weight.....	24,434 lb. (11 083 kg)	24,145 lb. (10 952 kg)	24,083 lb. (10 924 kg)	24,024 lb. (10 897 kg)

\*Allied attachments ordered through John Deere dealers.

Loader operating information is based on machine with all standard equipment; 17.5-25, 12 PR L2 tires; two rear counterweights; ROPS cab; 175-lb. (79 kg) operator; and full fuel tank. This information is affected by tire size, ballast, and different attachments.

**544G ADJUSTMENTS TO OPERATING WEIGHTS FOR TOOL CARRIER WITH BUCKET**

**Adjustments to operating weights and tipping loads for 2.25 cu. yd. (1.7 m<sup>3</sup>) general-purpose bucket and 48-in. (1219 mm) pallet fork**

Add (+) or deduct (-) lb. (kg) as indicated for loaders with	Operating Weight	Tipping Load, Bucket, Straight	Tipping Load, Bucket, Full Turn	Tipping Load, Fork, Straight	Tipping Load, Fork, Full Turn
15.5-25, 12 PR L2 tires without CaCl <sub>2</sub>	- 194 lb. (- 88 kg)	- 134 lb. (- 61 kg)	- 115 lb. (- 52 kg)	- 97 lb. (- 44 kg)	- 82 lb. (- 37 kg)
15.5-25, 12 PR L2 tires with CaCl <sub>2</sub>	+ 756 lb. (+ 343 kg)	+ 1,177 lb. (+ 534 kg)	+ 1,016 lb. (+ 461 kg)	+ 836 lb. (+ 379 kg)	+ 723 lb. (+ 328 kg)
17.5-25, 12 PR L2 tires with CaCl <sub>2</sub>	+ 1,180 lb. (+ 535 kg)	+ 1,629 lb. (+ 739 kg)	+ 1,407 lb. (+ 638 kg)	+ 1,158 lb. (+ 525 kg)	+ 1,003 lb. (+ 455 kg)
17.5-25, 12 PR L3 tires without CaCl <sub>2</sub>	+ 132 lb. (+ 60 kg)	+ 90 lb. (+ 41 kg)	+ 79 lb. (+ 36 kg)	+ 64 lb. (+ 29 kg)	+ 57 lb. (+ 26 kg)
17.5-25, 12 PR L3 tires with CaCl <sub>2</sub>	+ 1,312 lb. (+ 595 kg)	+ 1,720 lb. (+ 780 kg)	+ 1,486 lb. (+ 674 kg)	+ 1,222 lb. (+ 554 kg)	+ 1,056 lb. (+ 479 kg)
17.5-25, Radial, One Star L2 equivalent tires without CaCl <sub>2</sub>	+ 379 lb. (+ 172 kg)	+ 260 lb. (+ 118 kg)	+ 227 lb. (+ 103 kg)	+ 185 lb. (+ 84 kg)	+ 161 lb. (+ 73 kg)
17.5-25, Radial, One Star L2 equivalent tires with CaCl <sub>2</sub>	+ 1,559 lb. (+ 707 kg)	+ 1,890 lb. (+ 857 kg)	+ 1,632 lb. (+ 740 kg)	+ 1,345 lb. (+ 610 kg)	+ 1,162 lb. (+ 527 kg)
20.5-25, 12 PR L2 tires without CaCl <sub>2</sub>	+ 794 lb. (+ 360 kg)	+ 547 lb. (+ 248 kg)	+ 474 lb. (+ 215 kg)	+ 388 lb. (+ 176 kg)	+ 335 lb. (+ 152 kg)
20.5-25, 12 PR L2 tires with CaCl <sub>2</sub>	+ 2,615 lb. (+ 1186 kg)	+ 3,061 lb. (+ 1388 kg)	+ 2,644 lb. (+ 1199 kg)	+ 2,178 lb. (+ 988 kg)	+ 1,883 lb. (+ 854 kg)
20.5-25, 12 PR L3 tires without CaCl <sub>2</sub>	+ 1,085 lb. (+ 492 kg)	+ 750 lb. (+ 340 kg)	+ 646 lb. (+ 293 kg)	+ 530 lb. (+ 240 kg)	+ 458 lb. (+ 208 kg)
20.5-25, 12 PR L3 tires with CaCl <sub>2</sub>	+ 2,906 lb. (+ 1318 kg)	+ 3,261 lb. (+ 1479 kg)	+ 2,818 lb. (+ 1278 kg)	+ 2,420 lb. (+ 1098 kg)	+ 2,093 lb. (+ 950 kg)
ROPS canopy in lieu of ROPS cab	- 320 lb. (- 145 kg)	- 295 lb. (- 134 kg)	- 240 lb. (- 109 kg)	- 212 lb. (- 96 kg)	- 170 lb. (- 77 kg)
Deduct two rear counterweights	- 1,736 lb. (- 787 kg)	- 3,805 lb. (- 1726 kg)	- 3,127 lb. (- 1418 kg)	- 2,712 lb. (- 1230 kg)	- 2,227 lb. (- 1010 kg)
Deduct one rear counterweight*	- 946 lb. (- 429 kg)	- 2,092 lb. (- 949 kg)	- 1,718 lb. (- 779 kg)	- 1,488 lb. (- 675 kg)	- 1,222 lb. (- 554 kg)

\*Optional counterweight not to be used when CaCl<sub>2</sub> ballast is used in the tires.

**544G TOOL CARRIER INFORMATION (COUPLER AND FORKS)**

Tine Length	48 in. (1219 mm)	54 in. (1372 mm)	60 in. (1524 mm)
Ground to top of tine clearance	11 ft. 4.7 in. (3473 mm)	11 ft. 4.7 in. (3473 mm)	11 ft. 4.7 in. (3473 mm)
Maximum reach with fork level	4 ft. 9.5 in. (1461 mm)	4 ft. 9.5 in. (1461 mm)	4 ft. 9.5 in. (1461 mm)
Overall length	25 ft. 3.9 in. (7720 mm)	26 ft. 9.9 in. (7872 mm)	26 ft. 3.9 in. (8024 mm)
Tipping load, straight (fork level, load centered on tine)	13,665 lb. (6198 kg)	13,240 lb. (6006 kg)	12,899 lb. (5851 kg)
Tipping load, 40-degree full turn (fork level, load centered on tine)	11,541 lb. (5235 kg)	11,224 lb. (5091 kg)	10,925 lb. (4956 kg)
Operating weight	23,827 lb. (10 808 kg)	23,869 lb. (10 827 kg)	23,909 lb. (10 845 kg)

**544G TOOL CARRIER INFORMATION (COUPLER AND MATERIAL-HANDLING ARM)**

Boom Position	Retracted	Mid-position	Extended
Operating load	3,795 lb. (1721 kg)	3,966 lb. (1799 kg)	2,585 lb. (1173 kg)
Tipping load, straight	8,945 lb. (4057 kg)	6,998 lb. (3174 kg)	6,103 lb. (2768 kg)
Tipping load, 40-degree full turn	7,589 lb. (3442 kg)	5,932 lb. (2691 kg)	5,171 lb. (2346 kg)
Operating weight	23,633 lb. (10 720 kg)	23,633 lb. (10 720 kg)	23,633 lb. (10 720 kg)

**624G TOOL CARRIER INFORMATION (COUPLER AND BUCKET)**

Bucket Type/Size	General Purpose*	General Purpose*	General Purpose*
Capacity, heaped SAE	3.0 cu. yd. (2.3 m <sup>3</sup> )	2.63 cu. yd. (2.0 m <sup>3</sup> )	2.25 cu. yd. (1.7 m <sup>3</sup> )
Capacity, struck SAE	2.63 cu. yd. (2.0 m <sup>3</sup> )	2.25 cu. yd. (1.7 m <sup>3</sup> )	1.88 cu. yd. (1.44 m <sup>3</sup> )
Bucket width	101.8 in. (2.59 m)	101.8 in. (2.59 m)	100.4 in. (2.55 m)
Breakout force, SAE J732C	27,280 lb. (121.3 kN)	29,770 lb. (132.4 kN)	32,696 lb. (145.4 kN)
Tipping load, straight	20,107 lb. (9119 kg)	20,184 lb. (9154 kg)	21,058 lb. (9550 kg)
Tipping load, 40-degree full turn, SAE	17,016 lb. (7717 kg)	17,098 lb. (7754 kg)	17,882 lb. (8110 kg)
Reach, 45-degree dump, 7-ft. (2.13 m) clearance	59.9 in. (1522 mm)	58.6 in. (1489 mm)	58.2 in. (1478 mm)
Reach, 45-degree dump, full height	39.6 in. (1007 mm)	36.8 in. (936 mm)	34.8 in. (884 mm)
▲ Dump clearance, 45 degree, full height	110.1 in. (2797 mm)	112.8 in. (2865 mm)	116 in. (2946 mm)
Overall length	24 ft 9.5 in. (7.56 m)	24 ft 5.3 in. (7.45 m)	24 ft. 0.8 in. (7.34 m)
Loader clearance circle, bucket in carry position	39 ft. 5.2 in. (12.02 m)	39 ft. 2.8 in. (11.96 m)	38 ft. 10.8 in. (11.86 m)
Operating weight	27,880 lb. (12 644 kg)	27,796 lb. (12 606 kg)	27,432 lb. (12 441 kg)

\*Allied attachments ordered through John Deere dealers.

Loader operating information is based on machine with all standard equipment; 20.5-25, 12 PR L2 tires; one rear counterweight; ROPS cab; 175-lb. (79 kg) operator; and full fuel tank. This information is affected by tire size, ballast, and different attachments.

**624G ADJUSTMENTS TO OPERATING WEIGHTS FOR TOOL CARRIER WITH BUCKET**

**Adjustments to operating weights and tipping loads for 2.63 cu. yd. (2.0 m<sup>3</sup>) general-purpose bucket and 54-in. (1372 mm) pallet fork**

Add (+) or deduct (-) lb. (kg) as indicated for loaders with	Operating Weight	Tipping Load, Bucket, Straight	Tipping Load, Bucket, Full Turn	Tipping Load, Fork, Straight	Tipping Load, Fork, Full Turn
17.5-25, 12 PR L2 tires without CaCl <sub>2</sub>	- 794 lb. (- 360 kg)	- 536 lb. (- 243 kg)	- 461 lb. (- 209 kg)	- 386 lb. (- 175 kg)	- 335 lb. (- 152 kg)
17.5-25, 12 PR L2 tires with CaCl <sub>2</sub>	+ 386 lb. (+ 175 kg)	+ 1,054 lb. (+ 478 kg)	+ 911 lb. (+ 413 kg)	+ 763 lb. (+ 346 kg)	+ 657 lb. (+ 298 kg)
17.5-25, 12 PR L3 tires without CaCl <sub>2</sub>	- 661 lb. (- 300 kg)	- 448 lb. (- 203 kg)	- 384 lb. (- 174 kg)	- 320 lb. (- 145 kg)	- 280 lb. (- 127 kg)
17.5-25, 12 PR L3 tires with CaCl <sub>2</sub>	+ 518 lb. (+ 235 kg)	+ 1,142 lb. (+ 518 kg)	+ 988 lb. (+ 448 kg)	+ 829 lb. (+ 376 kg)	+ 714 lb. (+ 324 kg)
17.5-25, Radial, One Star L2 equivalent tires without CaCl <sub>2</sub>	- 414 lb. (- 188 kg)	- 280 lb. (- 127 kg)	- 240 lb. (- 109 kg)	- 201 lb. (- 91 kg)	- 174 lb. (- 79 kg)
17.5-25, Radial, One Star L2 equivalent tires with CaCl <sub>2</sub>	+ 765 lb. (+ 347 kg)	+ 1,310 lb. (+ 594 kg)	+ 1,131 lb. (+ 513 kg)	+ 948 lb. (+ 430 kg)	+ 816 lb. (+ 370 kg)
20.5-25, 12 PR L2 tires with CaCl <sub>2</sub>	+ 1,820 lb. (+ 826 kg)	+ 2,452 lb. (+ 1112 kg)	+ 2,119 lb. (+ 961 kg)	+ 1,777 lb. (+ 806 kg)	+ 1,532 lb. (+ 695 kg)
20.5-25, 12 PR L3 tires without CaCl <sub>2</sub>	+ 291 lb. (+ 132 kg)	+ 196 lb. (+ 89 kg)	+ 170 lb. (+ 77 kg)	+ 143 lb. (+ 65 kg)	+ 123 lb. (+ 56 kg)
20.5-25, 12 PR L3 tires with CaCl <sub>2</sub>	+ 2,112 lb. (+ 958 kg)	+ 2,646 lb. (+ 1200 kg)	+ 2,286 lb. (+ 1037 kg)	+ 1,918 lb. (+ 870 kg)	+ 1,654 lb. (+ 750 kg)
20.5-25, Radial, One Star L2 equivalent tires without CaCl <sub>2</sub>	+ 467 lb. (+ 212 kg)	+ 315 lb. (+ 143 kg)	+ 271 lb. (+ 123 kg)	+ 229 lb. (+ 104 kg)	+ 196 lb. (+ 89 kg)
20.5-25, Radial, One Star L2 equivalent tires with CaCl <sub>2</sub>	+ 2,288 lb. (+ 1038 kg)	+ 2,765 lb. (+ 1254 kg)	+ 2,390 lb. (+ 1084 kg)	+ 2,004 lb. (+ 909 kg)	+ 1,728 lb. (+ 784 kg)
ROPS canopy in lieu of ROPS cab	- 320 lb. (- 145 kg)	- 286 lb. (- 130 kg)	- 264 lb. (- 120 kg)	- 223 lb. (- 101 kg)	- 210 lb. (- 95 kg)
Deduct one rear counterweight	- 946 lb. (- 429 kg)	- 2,044 lb. (- 927 kg)	- 1,678 lb. (- 761 kg)	- 1,471 lb. (- 667 kg)	- 1,211 lb. (- 549 kg)
Add second rear counterweight*	+ 1,169 lb. (+ 530 kg)	+ 2,564 lb. (+ 1,163 kg)	+ 2,101 lb. (+ 953 kg)	+ 1,850 lb. (+ 839 kg)	+ 1,517 lb. (+ 688 kg)

\*Optional counterweight not to be used when CaCl<sub>2</sub> ballast is used in the tires.

**6246 TOOL CARRIER INFORMATION (COUPLER AND FORKS)**

Tine Length	48 in. (1219 mm)	54 in. (1372 mm)	60 in. (1524 mm)
Ground to top of tine clearance	11 ft. 10.6 in. (3623 mm)	11 ft. 10.6 in. (3623 mm)	11 ft. 10.6 in. (3623 mm)
Maximum reach with fork level	4 ft. 9.5 in. (1460 mm)	4 ft. 9.5 in. (1460 mm)	4 ft. 9.5 in. (1460 mm)
Overall length	25 ft. 8 in. (7823 mm)	26 ft. 2 in. (7975 mm)	26 ft. 8 in. (8128 mm)
Tipping load, straight (fork level, load centered on tine)	15,222 lb. (6903 kg)	14,790 lb. (6707 kg)	14,380 lb. (6522 kg)
Tipping load, 40-degree full turn (fork level, load centered on tine)	12,930 lb. (5864 kg)	12,560 lb. (5696 kg)	12,205 lb. (5535 kg)
Operating weight	27,190 lb. (12 331 kg)	27,232 lb. (12 350 kg)	27,271 lb. (12 368 kg)

**6246 TOOL CARRIER INFORMATION (COUPLER AND MATERIAL-HANDLING ARM)**

Boom Position	Retracted	Mid-position	Extended
Operating load	4,271 lb. (1937 kg)	3,354 lb. (1521 kg)	2,573 lb. (1167 kg)
Tipping load, straight	10,059 lb. (4562 kg)	7,903 lb. (3584 kg)	5,956 lb. (2701 kg)
Tipping load, 40-degree full turn	8,542 lb. (3874 kg)	6,708 lb. (3042 kg)	5,164 lb. (2334 kg)
Operating weight	26,996 lb. (12 243 kg)	26,996 lb. (12 243 kg)	26,996 lb. (12 243 kg)

**6446 TOOL CARRIER INFORMATION (COUPLER AND BUCKET)**

Bucket Type/Size	General Purpose*	General Purpose*
Capacity, heaped SAE	3.75 cu. yd. (2.8 m <sup>3</sup> )	3.25 cu. yd. (2.5 m <sup>3</sup> )
Capacity, struck SAE	3.17 cu. yd. (2.42 m <sup>3</sup> )	2.78 cu. yd. (2.13 m <sup>3</sup> )
Bucket width	112.2 in. (2.85 m)	112.2 in. (2.85 m)
Breakout force, SAE J732C	35,317 lb. (157.1 kN)	38,085 lb. (169.4 kN)
Tipping load, straight	26,228 lb. (11 895 kg)	26,595 lb. (12 061 kg)
Tipping load, 35-degree full turn, SAE	22,945 lb. (10 406 kg)	23,283 lb. (10 559 kg)
Tipping load, 40-degree full turn, SAE	22,147 lb. (10 044 kg)	22,478 lb. (10 194 kg)
Reach, 45-degree dump, 7-ft. (2.13 m) clearance	65.0 in. (1652 mm)	63.7 in. (1618 mm)
Reach, 45-degree dump, full height	44.8 in. (1138 mm)	42.3 in. (1075 mm)
▲ Dump clearance, 45 degree, full height	113.0 in. (2871 mm)	115.6 in. (2935 mm)
Overall length	25 ft 8.3 in. (7.83 m)	25 ft. 4.5 in. (7.73 m)
Loader clearance circle, bucket in carry position	41 ft. 10.8 in. (12.77 m)	41 ft. 8.6 in. (12.72 m)
Operating weight	35,553 lb. (16 124 kg)	35,384 lb. (16 047 kg)

\*Allied attachments ordered through John Deere dealers.

Loader operating information is based on machine with all standard equipment; 23.5-25, 12 PR L2 tires; one rear counterweight; ROPS cab; 175-lb. (79 kg) operator; and full fuel tank. This information is affected by tire size, ballast, and different attachments.

**6446 ADJUSTMENTS TO OPERATING WEIGHTS FOR TOOL CARRIER WITH BUCKET**

Adjustments to operating weights and tipping loads for 3.25 cu. yd. (2.5 m<sup>3</sup>) general-purpose bucket and 60-in. (1524 mm) pallet fork

Add (+) or deduct (-) lb. (kg) as indicated for loaders with	Operating Weight	Tipping Load, Bucket, Straight	Tipping Load, Bucket, 35° Turn	Tipping Load, Bucket, Full Turn	Tipping Load, Fork, Straight	Tipping Load, Fork, 35° Turn	Tipping Load, Fork, Full Turn
20.5-25, 12 PR L2 tires without CaCl <sub>2</sub>	-1,587 lb. (-720 kg)	-1,109 lb. (-503 kg)	-988 lb. (-448 kg)	-959 lb. (-435 kg)	-745 lb. (-338 kg)	-663 lb. (-300 kg)	-642 lb. (-291 kg)
20.5-25, 12 PR L2 tires with CaCl <sub>2</sub>	+234 lb. (+106 kg)	+1,435 lb. (+651 kg)	+1,277 lb. (+579 kg)	+1,239 lb. (+562 kg)	+983 lb. (+446 kg)	+875 lb. (+397 kg)	+850 lb. (+386 kg)
20.5-25, 16 PR L2 tires without CaCl <sub>2</sub>	-1,499 lb. (-680 kg)	-1,047 lb. (-475 kg)	-933 lb. (-423 kg)	-906 lb. (-411 kg)	-705 lb. (-320 kg)	-626 lb. (-284 kg)	-608 lb. (-276 kg)
20.5-25, 16 PR L2 tires with CaCl <sub>2</sub>	+322 lb. (+146 kg)	+1,497 lb. (+679 kg)	+1,332 lb. (+604 kg)	+1,292 lb. (+586 kg)	+1,023 lb. (+464 kg)	+912 lb. (+414 kg)	+885 lb. (+401 kg)
20.5-25, 16 PR L3 tires without CaCl <sub>2</sub>	-1,235 lb. (-560 kg)	-862 lb. (-391 kg)	-767 lb. (-348 kg)	-745 lb. (-338 kg)	-580 lb. (-263 kg)	-514 lb. (-233 kg)	-498 lb. (-226 kg)
20.5-25, 16 PR L3 tires with CaCl <sub>2</sub>	+586 lb. (+266 kg)	+1,682 lb. (+763 kg)	+1,495 lb. (+678 kg)	+1,451 lb. (+658 kg)	+1,148 lb. (+521 kg)	+1,024 lb. (+465 kg)	+994 lb. (+451 kg)
20.5-25, Radial, One Star L2 equivalent tires without CaCl <sub>2</sub>	-1,120 lb. (-508 kg)	-783 lb. (-355 kg)	-697 lb. (-316 kg)	-677 lb. (-307 kg)	-524 lb. (-237 kg)	-463 lb. (-210 kg)	-450 lb. (-204 kg)
20.5-25, Radial, One Star L2 equivalent tires with CaCl <sub>2</sub>	+701 lb. (+318 kg)	+1,762 lb. (+799 kg)	+1,566 lb. (+710 kg)	+1,433 lb. (+650 kg)	+1,204 lb. (+546 kg)	+1,075 lb. (+488 kg)	+1,042 lb. (+473 kg)
20.5-25, 12 PR L2 tires with CaCl <sub>2</sub>	+2,396 lb. (+1087 kg)	+3,347 lb. (+1518 kg)	+2,979 lb. (+1351 kg)	+2,891 lb. (+1311 kg)	+2,283 lb. (+1035 kg)	+2,031 lb. (+921 kg)	+1,972 lb. (+894 kg)
23.5-25, 20 PR L3 tires without CaCl <sub>2</sub>	+494 lb. (+224 kg)	+344 lb. (+156 kg)	+306 lb. (+139 kg)	+298 lb. (+135 kg)	+243 lb. (+110 kg)	+218 lb. (+99 kg)	+209 lb. (+95 kg)
23.5-25, 20 PR L3 tires with CaCl <sub>2</sub>	+2,890 lb. (+1311 kg)	+3,691 lb. (+1674 kg)	+3,285 lb. (+1490 kg)	+3,188 lb. (+1446 kg)	+2,518 lb. (+1142 kg)	+2,242 lb. (+1017 kg)	+2,177 lb. (+987 kg)
ROPS canopy in lieu of ROPS cab	-320 lb. (-145 kg)	-298 lb. (-135 kg)	-251 lb. (-114 kg)	-238 lb. (-108 kg)	-201 lb. (-91 kg)	-170 lb. (-77 kg)	-161 lb. (-73 kg)
Deduct one rear counterweight	-910 lb. (-413 kg)	-2,031 lb. (-921 kg)	-1,740 lb. (-789 kg)	-1,669 lb. (-757 kg)	-1,373 lb. (-622 kg)	-1,176 lb. (-533 kg)	-1,126 lb. (-511 kg)
Add second rear counterweight*	+1,422 lb. (+645 kg)	+3,197 lb. (+1450 kg)	+2,736 lb. (+1241 kg)	+2,622 lb. (+1189 kg)	+2,179 lb. (+988 kg)	+1,868 lb. (+847 kg)	+1,790 lb. (+812 kg)

\*Optional counterweight not to be used when CaCl<sub>2</sub> ballast is used in the tires.

**6446 TOOL CARRIER INFORMATION (COUPLER AND FORKS)**

Tine Length	54 in. (1372 mm)	60 in. (1524 mm)	72 in. (1829 mm)
Ground to top of tine clearance	12 ft. 6.3 in. (3818 mm)	12 ft. 6.3 in. (3818 mm)	12 ft. 6.3 in. (3818 mm)
Maximum reach with fork level	5 ft. 1.7 in. (1568 mm)	5 ft. 1.7 in. (1568 mm)	5 ft. 1.7 in. (1568 mm)
Overall length	27 ft. 2.3 in. (8287 mm)	27 ft. 8.3 in. (8439 mm)	28 ft. 8.3 in. (8744 mm)
Tipping load, straight (fork level, load centered on tine)	18,251 lb. (8277 kg)	17,755 lb. (8052 kg)	16,809 lb. (7623 kg)
Tipping load, 35-degree turn (fork level, load centered on tine)	15,953 lb. (7235 kg)	15,511 lb. (7034 kg)	14,670 lb. (6653 kg)
Tipping load, 40-degree full turn (fork level, load centered on tine)	15,389 lb. (6979 kg)	14,963 lb. (6786 kg)	14,149 lb. (6417 kg)
Operating weight	35,309 lb. (16 013 kg)	35,379 lb. (16 045 kg)	35,523 lb. (16 110 kg)

**6446 TOOL CARRIER INFORMATION (COUPLER AND MATERIAL-HANDLING ARM)**

Boom Position	Retracted	Mid-position	Extended
Operating load	5,640 lb. (2558 kg)	4,462 lb. (2024 kg)	3,902 lb. (1770 kg)
Tipping load, straight	13,290 lb. (6027 kg)	10,518 lb. (4770 kg)	9,204 lb. (4174 kg)
Tipping load, 35-degree turn	11,671 lb. (5293 kg)	9,235 lb. (4188 kg)	8,077 lb. (3663 kg)
Tipping load, 40-degree full turn	11,281 lb. (5116 kg)	8,924 lb. (4047 kg)	7,803 lb. (3539 kg)
Operating weight	34,114 lb. (15 471 kg)	34,114 lb. (15 471 kg)	34,114 lb. (15 471 kg)