



**JOHN DEERE**

24-27 METRIC TONS

**D**

**EXCAVATORS**

**240D LC | 270D LC**





# Armed forces.

Bigger, stronger, faster, and quieter. The new 240D LC and 270D LC are armed and ready to take on your world. Both deliver the power, smoothness, ease of operation, and comfort you'd expect from John Deere excavators — and then some. Each features a rugged, fuel-efficient Tier 3

PowerTech Plus™ engine; an enhanced cooling system; and extended service intervals for industry-leading uptime and serviceability. And with other refinements such as faster hydraulics, better visibility, and a roomier, more comfortable cab, Deere once again sets the standard.



Specifications	240D LC	270D LC
Net Horsepower	177 hp	188 hp
Operating Weight	54,624 lb.	63,425 lb.
Lift Capacity	16,877 lb.	19,727 lb.
Digging Depth	24 ft. 7 in.	25 ft. 11 in.
Arm Breakout Force	24,020 lb.	25,979 lb.

- 240D LC and 270D LC deliver more digging force, swing torque, and lift capability, with less emissions and noise.
- Extended engine and hydraulic oil service intervals increase uptime and reduce daily operating costs.
- Redesigned cab is more spacious and has 47-percent more glass for best-in-class comfort and visibility.
- Powerwise™ III engine/hydraulic management system maximizes power output, saves fuel, and delivers smooth multifunction hydraulic operation.
- Hydraulically driven, highly efficient fan runs only as needed, reducing noise, fuel consumption, and operating costs.
- Tier 3 emission-certified PowerTech Plus diesels deliver power without compromise in all conditions.



Electronically controlled variable-geometry turbo-charger (VGT) improves torque response, helping match engine speed to load requirements.

Noise levels — and operator fatigue — have been significantly reduced. Variable-speed fan, dual-pass muffler, pilot-injected PowerTech Plus engine, and isochronous high-idle speed help quiet things down.

Cooled exhaust gas recirculation (EGR), four-valve-per-cylinder head, and high-pressure common-rail fuel system enable the 6.8-L diesels to meet Tier 3 emission standards without sacrificing power or fuel efficiency.

Additional hydraulic capability a necessity? Two factory-installed high-pressure, high-flow auxiliary hydraulic packages enable you to meet the need.

Choose from a variety of track widths, arm lengths, buckets, and other options.



1. Powerwise III perfectly balances engine performance and hydraulic flow for fast, smooth, and predictable operation. One work mode makes it easy to be productive in any application.
2. Significant increases in horsepower, weight, dig force, and drawbar pull make the D-Series highly productive machines for a wide variety of work.
3. Increased flow, arm force, and swing torque help speed cycles, enabling you to load more trucks or open more trench.
4. For work that requires extra finesse, the D-Series' best-in-class metering and smooth multifunction operation give you the precise control you need.





# Quietly go about your business of building your bottom line.

D-Series Excavators speak softly and carry a big stick. Combining strong digging forces with outstanding lift capacity and reach, the 240D LC and 270D LC are more than up to any task. Faster hydraulics boost productivity, while increased drawbar pull and arm force provide an additional lift to production.

The Powerwise III engine/hydraulic management system provides pinpoint metering and low-effort control, while numerous noise-reduction enhancements further reduce operator fatigue. Add any of the many available options, and put even more work within reach.







# See more, do more.

Yours aren't just any employees. Why equip them with just another excavator? To help make the most of their skills, put your operators behind the controls of a John Deere D-Series. Its spacious, well-appointed interior boasts more of everything. Forty-seven-percent more glass for virtually unrestricted visibility. Substantially more legroom.

And a bevy of creature comforts, including automatic climate control, AM/FM radio, generous storage space, and available air-suspension heated seat. But it's not just the extras that will make your operators more productive. They'll also benefit from the things the D-Series deliver less of — such as noise, fatigue, and emissions.



Deluxe-suspension multi-position seat has 10½ inches of travel, sliding together or independently of the control console. So it won't cramp an operator's style.

Ergonomically correct short-throw pilot levers provide smooth, predictable fingertip control with less movement or effort.

Pushbuttons in the right lever allow fingertip control of auxiliary hydraulic flow for operating attachments.

Convenient 12-volt port powers cell phones and other electronic devices.

Redesigned cab isn't just roomier, it's also noticeably quieter and more comfortable. Silicone-filled mounts effectively isolate operators from noise and vibration.

1. Wide expanse of glass, narrow front cab posts, large overhead tinted hatch, and numerous mirrors provide virtually unobstructed all-around visibility.
2. No shortage of storage in here. There's a place for a cooler, cup holders, and even a hot/cold box that keeps beverages at just the right temperature.
3. Automatic, high-velocity bi-level climate-control system with automotive-style adjustable louvers helps keep the glass clear and the cab comfortable.
4. Intuitive, multi-language monitor provides a wealth of machine info and control. Its LCD four-color screen displays operating, diagnostic, and maintenance data with easy-on-the-eyes clarity.





Graphite-iron wet-sleeve cylinder liners, mono-steel pistons, and large-diameter connecting rods ensure long-term engine durability.

Welded bulkheads within the boom resist torsional stress. Reinforced D-channel side frames provide maximum cab and component protection.

Tungsten-carbide coating creates an extremely wear-resistant surface to protect the all-important bucket-to-arm joint.

An optional reversing fan back-blows cooler cores to reduce debris buildup. It's a welcome addition that will increase uptime.

Oil-impregnated bushings enhance durability and extend grease intervals to 500 hours for the arm-and-boom joint and 100 hours for the bucket joint.

Booms, arms, and mainframes are so tough, they're warranted for three years or 10,000 hours.



**1.** Hydraulically driven cool-on-demand fan runs only as needed, reducing fuel consumption and debris flow through the coolers. Highly efficient system keeps things cool, even in tough environments or high altitudes.



**2.** Perforations in the hood and side shields serve as a "first filter," helping prevent trash entry. Anything that passes through will also clear the eight-fin-per-inch cooler cores.



**3.** Reinforced resin thrust plates, grooved bushings, and thermal-coated bucket joints increase arm and boom lube intervals to 500 hours.



**4.** You won't find a more durable swing bearing or mainframe on comparable-size excavators.





# Nothing runs like a Deere because nothing is built like one.



From their durable sealed and lubricated undercarriages to their heavy-duty fuel-sipping PowerTech Plus engines, the D-Series are built to the hilt to deliver unsurpassed reliability. These plus numerous other traditional John Deere features such as wet-sleeve engine liners,

tungsten-carbide thermal-coated arm surfaces, oil-impregnated bushings, welded-boom bulkheads, and extended engine and hydraulic oil-change intervals help keep downtime down and profits up. When you know how they're built, you'll run a Deere.

Machine Information Center (MIC) captures and stores vital machine performance and utilization data to help improve uptime, productivity, and profit.

Auto-idle automatically reduces engine speed when hydraulics aren't in use, helping make the most of every precious drop of fuel.

Large easy-to-open doors provide quick access to service items. Lube banks, filters, and checkpoints are grouped for added convenience.

Large fuel tanks and 500- and 5,000-hour engine and hydraulic oil-service intervals increase uptime and help lower daily operating costs.

Fluid-level sight gauges are conveniently located and can be checked at a glance.

Nobody backs you better than the 500-plus John Deere dealers throughout North America.





# Minimize maintenance, maximize results.

As with all John Deere machines, D-Series Excavators are loaded with features that make them hassle free to service and low cost to maintain. Large, easy-to-open service doors and easy-to-reach daily service points make quick work of the daily routine. Remote-mounted vertical

oil and fuel filters and extended engine and hydraulic oil-change intervals minimize periodic maintenance, too. Plus, the Machine Information Center (MIC) and remote fluid-sample ports help you make timely decisions about machine up-keep, further minimizing downtime and expense.

1. Vertical spin-on engine oil and fuel/water filters are positioned in the right rear compartment for simplified servicing.

4. Coolers' eight-fin-per-inch spacing lets trash easily pass to resist plugging. Hinged, swing-out coolers provide added core access.

2. Ground-level fresh-air cab filter is quickly serviced from outside the cab. Where it's more likely to get done.

5. Remote diagnostic and fluid-sample ports help speed preventative maintenance and troubleshooting.

3. Centralized lube banks place difficult-to-lube zerks within easy reach. Help make greasing less messy and time consuming, too.

6. Convenient door atop the hood speeds and simplifies daily engine oil and coolant checks.

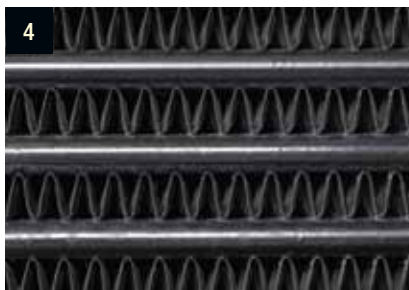

# Specifications

## Engine **240D LC**

Manufacturer and Model	John Deere 6068H
Non-Road Emission Standards	certified to EPA Tier 3 emissions
Net Power (ISO 9249)	177 hp (132 kW) @ 2,000 rpm
Cylinders	6
Displacement	415 cu. in. (6.8 L)
Off-Level Capacity	100% (45 deg.)
Aspiration	turbocharged, air-to-air charge air cooler

## Cooling

Cool-on-demand hydraulic-driven, suction-type fan with remote-mounted drive

## Powertrain

Two-speed propel with automatic shift

Maximum Travel Speed

Low	2.1 mph (3.4 km/h)
High	3.4 mph (5.5 km/h)

## Hydraulics

Open center, load sensing

**Main Pumps** . . . . . 2 variable-displacement pumps

Maximum Rated Flow . . . . . 2 x 59.2 gpm (2 x 224 L/m)

**Pilot Pump** . . . . . one gear

Maximum Rated Flow . . . . . 8.9 gpm (34 L/m)

Pressure Setting . . . . . 566 psi (3900 kPa)

**System Operating Pressure**

Implement Circuits . . . . . 4,980 psi (34 336 kPa)

Travel Circuits . . . . . 4,980 psi (34 336 kPa)

Swing Circuits . . . . . 4,700 psi (32 405 kPa)

Power Boost . . . . . 5,260 psi (36 266 kPa)

**Controls** . . . . . pilot levers, short stroke, low effort; hydraulic pilot controls with shutoff lever

## Cylinders

Heat-treated, chrome-plated, polished cylinder rods, hardened steel (replaceable bushings) pivot pins

	<i>Bore</i>	<i>Rod Diameter</i>	<i>Stroke</i>
Boom (2)	4.9 in. (124 mm)	3.5 in. (89 mm)	54.7 in. (1389 mm)
Arm (1)	5.5 in. (140 mm)	3.9 in. (99 mm)	63.4 in. (1610 mm)
Bucket (1)	5.1 in. (130 mm)	3.5 in. (89 mm)	42.3 in. (1074 mm)

## Electrical

Batteries . . . . . 2 x 12 volt

Alternator Rating . . . . . 80 amp

Work Lights . . . . . 2 halogen (one mounted on boom, one mounted on frame)

## Undercarriage

Carrier Rollers (per side) . . . . . 2

Track Rollers (per side) . . . . . 9

Shoes, Triple Semi-Grouser (per side) . . . . . 51

Drawbar Pull . . . . . 49,935 lb. (22 650 kg)

Track

Adjustment . . . . . hydraulic

Guides . . . . . 2 per side

Chain . . . . . sealed and lubricated



## Swing Mechanism

## 240D LC

Swing Speed .....	13.5 rpm
Swing Torque .....	54,857 lb.-ft. (74 376 Nm)

## Ground Pressure

Triple Semi-Grouser Shoes	
28 in. (700 mm) .....	6.02 psi (41.5 kPa)
32 in. (800 mm) .....	5.34 psi (36.8 kPa)

## Serviceability

### Refill Capacities

Fuel Tank .....	132 gal. (500 L)
Cooling System .....	8 gal. (29.9 L)
Engine Oil with Filter .....	7 gal. (24.6 L)
Hydraulic Tank .....	64 gal. (243 L)
Hydraulic System .....	74 gal. (280 L)

### Gearbox

Swing .....	7.5 qt. (7.1 L)
Propel (each) .....	6.5 qt. (6.2 L)
Pump Drive .....	1.2 qt. (1.1 L)

## Operating Weights

With Full Fuel Tank; 175-lb. (79 kg) Operator; 1.38-cu.-yd. (1.06 m<sup>3</sup>), 42-in. (1065 mm), 2,197-lb. (997 kg) Heavy-Duty Plate-Lip Bucket; 11-ft. 10-in. (3.61 m) Arm; 11,905-lb. (5400 kg) Counterweight; and 32-in. (800 mm) Triple Semi-Grouser Shoes. . . 56,815 lb. (25 771 kg)

### Optional Components

Undercarriage with Triple Semi-Grouser Shoes	
28 in. (700 mm) .....	18,667 lb. (8467 kg)
32 in. (800 mm) .....	19,294 lb. (8752 kg)
One-Piece Boom (with arm cylinder) .....	4,872 lb. (2210 kg)
Arm with Bucket Cylinder and Linkage	
9 ft. 9 in. (2.96 m) .....	2,858 lb. (1296 kg)
11 ft. 10 in. (3.61 m) .....	3,078 lb. (1396 kg)
Boom Lift Cylinders (2) Total Weight .....	958 lb. (434 kg)
1.38-cu.-yd. (1.06 m <sup>3</sup> ), 42-in. (1065 mm)	
Heavy-Duty Plate-Lip Bucket .....	2,197 lb. (997 kg)
Counterweight (standard) .....	11,905 lb. (5400 kg)

## Operating Dimensions

	Arm Length 9 ft. 9 in. (2.96 m)	Arm Length 11 ft. 10 in. (3.61 m)
Arm Force with 32-in. (800 mm) Triple Semi-Grouser Shoes with Power Boost .....	27,639 lb. (122.9 kN)	24,019 lb. (106.8 kN)
Bucket Digging Force with 32-in. (800 mm) Triple Semi-Grouser Shoes with Power Boost .....	37,668 lb. (167.6 kN)	37,668 lb. (167.6 kN)
Lifting Capacity Over Front @ Ground Level		
20-ft. (6.1 m) Reach with Power Boost .....	17,737 lb. (8045 kg)	16,892 lb. (7662 kg)
<b>A</b> Maximum Reach .....	33 ft. 9 in. (10.29 m)	35 ft. 10 in. (10.91 m)
<b>A'</b> Maximum Reach @ Ground Level .....	33 ft. 2 in. (10.11 m)	35 ft. 3 in. (10.75 m)
<b>B</b> Maximum Digging Depth .....	22 ft. 10 in. (6.96 m)	25 ft. 0 in. (7.61 m)
<b>B'</b> Maximum Digging Depth at 8-ft. (2.44 m) Flat Bottom .....	22 ft. 2 in. (6.75 m)	24 ft. 5 in. (7.44 m)
<b>C</b> Maximum Cutting Height .....	33 ft. 4 in. (10.16 m)	34 ft. 8 in. (10.56 m)
<b>D</b> Maximum Dumping Height .....	23 ft. 7 in. (7.20 m)	24 ft. 10 in. (7.58 m)
<b>E</b> Minimum Swing Radius .....	11 ft. 3 in. (3.44 m)	11 ft. 3 in. (3.43 m)
<b>F</b> Maximum Vertical Wall .....	19 ft. 9 in. (6.03 m)	22 ft. 1 in. (6.74 m)
<b>G</b> Tail Swing Radius .....	9 ft. 8 in. (2.94 m)	9 ft. 8 in. (2.94 m)

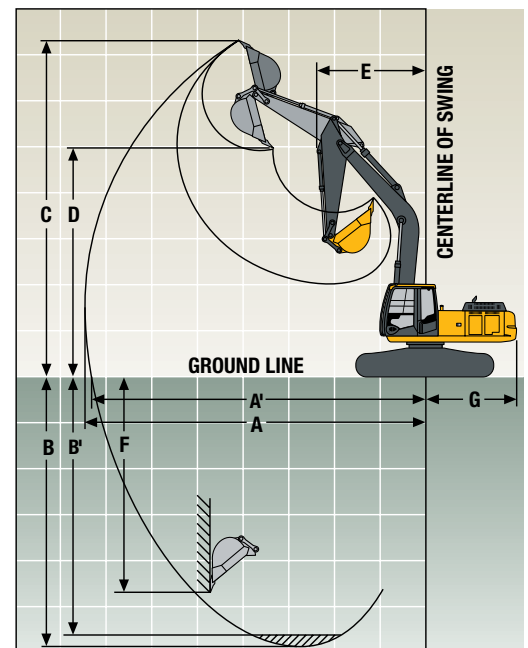

## Machine Dimensions

### 240D LC

	Arm Length 9 ft. 9 in. (2.96 m)	Arm Length 11 ft. 10 in. (3.61 m)
<b>A</b> Overall Length . . . . .	33 ft. 4 in. (10.15 m)	33 ft. 6 in. (10.20 m)
<b>B</b> Overall Height . . . . .	10 ft. 1 in. (3.07 m)	10 ft. 11 in. (3.32 m)
<b>C</b> Rear-End Length/Swing Radius . . . . .	9 ft. 8 in. (2.94 m)	
<b>D</b> Distance Between Idler/Sprocket Centerline . . . . .	12 ft. 8 in. (3.85 m)	
<b>E</b> Undercarriage Length . . . . .	15 ft. 3 in. (4.64 m)	
<b>F</b> Counterweight Clearance . . . . .	3 ft. 7 in. (1.09 m)	
<b>G</b> Upperstructure Width . . . . .	9 ft. 6 in. (2.89 m)	
<b>H</b> Cab Height . . . . .	9 ft. 11 in. (3.01 m)	
<b>I</b> Track Width with Triple Semi-Grouser Shoes . . . . .	24 in. (600 mm) / 28 in. (700 mm) / 32 in. (800 mm)	
<b>J</b> Gauge Width . . . . .	7 ft. 10 in. (2.39 m)	
<b>K</b> Ground Clearance . . . . .	18 in. (460 mm)	
<b>L</b> Overall Width with Triple Semi-Grouser Shoes		
24 in. (600 mm) . . . . .	9 ft. 10 in. (2.99 m)	
28 in. (700 mm) . . . . .	10 ft. 2 in. (3.09 m)	
32 in. (800 mm) . . . . .	10 ft. 6 in. (3.19 m)	

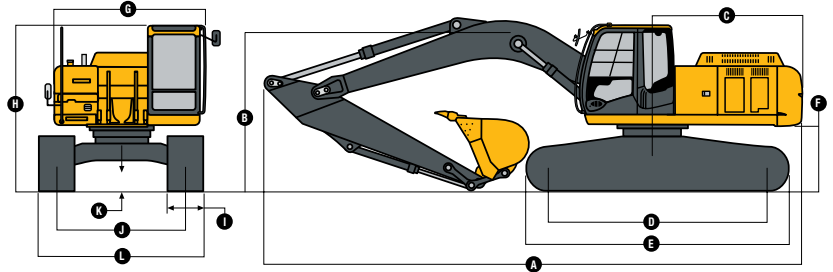

## Lift Charts

**Boldface italic** type indicates hydraulic-limited capacities; lightface type indicates stability-limited capacities, in lb. (kg). Ratings are at bucket lift hook; using 1.4-cu.-yd. (1.06 m<sup>3</sup>) bucket; standard counterweight; standard gauge; and situated on firm, uniform supporting surface. Figures do not exceed 87 percent of hydraulic capacities or 75 percent of weight needed to tip machine.

Load Point Height	10 ft. (3.05 m)		15 ft. (4.57 m)		20 ft. (6.10 m)		25 ft. (7.62 m)		30 ft. (9.14 m)	
	Over Front	Over Side	Over Front	Over Side	Over Front	Over Side	Over Front	Over Side	Over Front	Over Side
<i>With 9-ft. 9-in. (2.96 m) arm and 28-in. (700 mm) triple-grouser shoes</i>										
20 ft. (6.10 m)							<b>8,236 (3736)</b>	<b>8,236 (3736)</b>		
15 ft. (4.57 m)					<b>10,540 (4781)</b>	<b>10,540 (4781)</b>	<b>9,886 (4484)</b>	9,017 (4090)		
10 ft. (3.05 m)			<b>17,516 (7945)</b>	<b>17,516 (7945)</b>	<b>13,047 (5918)</b>	12,588 (5710)	<b>11,074 (5023)</b>	8,624 (3912)	<b>7,205 (3268)</b>	6,113 (2773)
5 ft. (1.52 m)			<b>23,155 (10 503)</b>	18,058 (8191)	<b>15,754 (7146)</b>	11,722 (5317)	<b>12,483 (5662)</b>	8,184 (3712)	<b>9,207 (4176)</b>	5,922 (2686)
Ground Line			<b>25,633 (11 627)</b>	17,214 (7808)	<b>17,721 (8038)</b>	11,105 (5037)	12,586 (5709)	7,826 (3550)	<b>9,235 (4189)</b>	5,754 (2610)
-5 ft. (-1.52 m)	<b>12,760 (5788)</b>	<b>12,760 (5788)</b>	<b>25,653 (11 636)</b>	17,044 (7731)	17,705 (8031)	10,818 (4907)	12,372 (5612)	7,630 (3461)		
-10 ft. (-3.05 m)	<b>19,352 (8778)</b>	<b>19,352 (8778)</b>	<b>24,123 (10 942)</b>	17,196 (7800)	17,705 (8031)	10,816 (4906)	12,390 (5620)	7,646 (3468)		
-15 ft. (-4.57 m)	<b>27,604 (12 521)</b>	<b>27,604 (12 521)</b>	<b>20,730 (9403)</b>	17,635 (7999)	<b>15,487 (7025)</b>	11,109 (5039)				
<i>With 11-ft. 10-in. (3.61 m) arm and 28-in. (700 mm) triple-grouser shoes</i>										
20 ft. (6.10 m)							<b>7,549 (3424)</b>	<b>7,549 (3424)</b>		
15 ft. (4.57 m)					<b>8,519 (3864)</b>	<b>8,519 (3864)</b>	<b>8,607 (3904)</b>	<b>8,607 (3904)</b>	<b>6,261 (2840)</b>	<b>6,261 (2840)</b>
10 ft. (3.05 m)			<b>14,687 (6662)</b>	<b>14,687 (6662)</b>	<b>11,557 (5242)</b>	<b>11,557 (5242)</b>	<b>10,049 (4558)</b>	8,774 (3980)	<b>8,091 (3670)</b>	6,206 (2815)
5 ft. (1.52 m)			<b>20,757 (9415)</b>	18,695 (8480)	<b>14,487 (6571)</b>	11,960 (5425)	<b>11,625 (5273)</b>	8,282 (3757)	9,579 (4345)	5,955 (2701)
Ground Line			<b>24,564 (11 142)</b>	17,417 (7900)	<b>16,876 (7655)</b>	11,211 (5085)	12,628 (5728)	7,853 (3562)	9,332 (4233)	5,725 (2597)
-5 ft. (-1.52 m)	<b>13,060 (5924)</b>	<b>13,060 (5924)</b>	<b>25,706 (11 660)</b>	16,960 (7693)	17,688 (8023)	10,785 (4892)	12,322 (5589)	7,575 (3436)	9,182 (4165)	5,587 (2534)
-10 ft. (-3.05 m)	<b>22,507 (10 209)</b>	<b>22,507 (10 209)</b>	<b>25,005 (11 342)</b>	16,951 (7689)	17,551 (7961)	10,666 (4838)	12,229 (5547)	7,489 (3397)		
-15 ft. (-4.57 m)	<b>29,632 (13 441)</b>	<b>29,632 (13 441)</b>	<b>22,540 (10 224)</b>	17,258 (7828)	<b>16,709 (7579)</b>	10,825 (4910)	<b>12,306 (5582)</b>	7,663 (3476)		
-20 ft. (-6.10 m)			<b>17,275 (7836)</b>	<b>17,275 (7836)</b>	<b>12,097 (5487)</b>	11,396 (5169)				
<i>With 9-ft. 9-in. (2.96 m) arm and 32-in. (800 mm) triple-grouser shoes</i>										
20 ft. (6.10 m)							<b>8,236 (3736)</b>	<b>8,236 (3736)</b>		
15 ft. (4.57 m)					<b>10,540 (4781)</b>	<b>10,540 (4781)</b>	<b>9,886 (4484)</b>	9,123 (4138)		
10 ft. (3.05 m)			<b>17,516 (7945)</b>	<b>17,516 (7945)</b>	<b>13,047 (5918)</b>	12,725 (5772)	<b>11,074 (5023)</b>	8,728 (3959)	<b>7,205 (3268)</b>	6,196 (2810)
5 ft. (1.52 m)			<b>23,155 (10 503)</b>	18,263 (8284)	<b>15,754 (7146)</b>	11,859 (5379)	<b>12,483 (5662)</b>	8,287 (3759)	<b>9,207 (4176)</b>	6,003 (2723)
Ground Line			<b>25,633 (11 627)</b>	17,417 (7900)	<b>17,721 (8038)</b>	11,241 (5099)	12,745 (5781)	7,930 (3597)	<b>9,235 (4189)</b>	5,838 (2648)
-5 ft. (-1.52 m)	<b>12,760 (5788)</b>	<b>12,760 (5788)</b>	<b>25,653 (11 636)</b>	17,249 (7824)	17,921 (8129)	10,955 (4969)	12,531 (5684)	7,734 (3508)		
-10 ft. (-3.05 m)	<b>19,352 (8778)</b>	<b>19,352 (8778)</b>	<b>24,123 (10 942)</b>	17,399 (7892)	17,921 (8129)	10,953 (4968)	12,549 (5692)	7,749 (3515)		
-15 ft. (-4.57 m)	<b>27,604 (12 521)</b>	<b>27,604 (12 521)</b>	<b>20,730 (9403)</b>	17,835 (8090)	<b>15,487 (7025)</b>	11,248 (5102)				



**Lift Capacities (continued)**

**240D LC**

*Boldface italic* type indicates hydraulic-limited capacities; lightface type indicates stability-limited capacities, in lb. (kg). Ratings are at bucket lift hook; using 1.4-cu.-yd. (1.06 m<sup>3</sup>) bucket; standard counterweight; standard gauge; and situated on firm, uniform supporting surface. Figures do not exceed 87 percent of hydraulic capacities or 75 percent of weight needed to tip machine.

Load Point Height	10 ft. (3.05 m)		15 ft. (4.57 m)		20 ft. (6.10 m)		25 ft. (7.62 m)		30 ft. (9.14 m)	
	Over Front	Over Side	Over Front	Over Side	Over Front	Over Side	Over Front	Over Side	Over Front	Over Side
<i>With 11-ft. 10-in. (3.61 m) arm and 32-in. (800 mm) triple-grouser shoes</i>										
20 ft. (6.10 m)							<b>7,549 (3424)</b>	<b>7,549 (3424)</b>		
15 ft. (4.57 m)					<b>8,519 (3864)</b>	<b>8,519 (3864)</b>	<b>8,607 (3904)</b>	<b>8,607 (3904)</b>	<b>6,261 (2840)</b>	<b>6,261 (2840)</b>
10 ft. (3.05 m)			<b>14,687 (6662)</b>	<b>14,687 (6662)</b>	<b>11,557 (5242)</b>	<b>11,557 (5242)</b>	<b>10,049 (4558)</b>	8,878 (4027)	<b>8,091 (3670)</b>	6,290 (2853)
5 ft. (1.52 m)			<b>20,757 (9415)</b>	18,695 (8480)	<b>14,487 (6571)</b>	12,099 (5488)	<b>11,625 (5273)</b>	8,384 (3803)	<b>9,678 (4390)</b>	6,038 (2739)
Ground Line			<b>24,564 (11 142)</b>	17,619 (7992)	<b>16,876 (7655)</b>	11,347 (5147)	12,785 (5799)	7,956 (3609)	9,458 (4290)	5,809 (2635)
-5 ft. (-1.52 m)	<b>13,060 (5924)</b>	<b>13,060 (5924)</b>	<b>25,706 (11 660)</b>	17,163 (7785)	17,904 (8121)	10,924 (4955)	12,480 (5661)	7,679 (3483)	9,308 (4222)	5,670 (2572)
-10 ft. (-3.05 m)	<b>22,507 (10 209)</b>	<b>22,507 (10 209)</b>	<b>25,005 (11 342)</b>	17,154 (7781)	17,767 (8059)	10,805 (4901)	12,388 (5619)	7,593 (3444)		
-15 ft. (-4.57 m)	<b>29,632 (13 441)</b>	<b>29,632 (13 441)</b>	<b>22,540 (10 224)</b>	17,461 (7920)	<b>16,709 (7579)</b>	10,961 (4972)	<b>12,306 (5582)</b>	7,769 (3524)		
-20 ft. (-6.10 m)			<b>17,275 (7836)</b>	<b>17,275 (7836)</b>	<b>12,097 (5487)</b>	11,532 (5231)				

**Buckets**

A full line of buckets is offered to meet a wide variety of applications. Digging forces are with power boost. The buckets have an adjustable bushing for side clearance, with the exception of the ditching bucket. Tooth selection includes either the John Deere Fanggs®, Standard, Tiger, Twin Tiger, Abrasion panel, or Flare tooth, or the ESCO (Vertalok) Standard, Tiger, Twin Tiger, or Flare tooth. Replaceable cutting edges are available through John Deere parts. Optional side cutters add 6 inches (150 mm) to bucket widths. Capacities are SAE heaped ratings.

Bucket Type	Bucket Width		Bucket Capacity		Bucket Weight		Bucket Dig Force		Arm Dig Force 9 ft. 9 in. (2.96 m)		Arm Dig Force 11 ft. 10 in. (3.61 m)		Bucket Tip Radius		No. Teeth
	in.	mm	cu. yd.	m <sup>3</sup>	lb.	kg	lb.	kN	lb.	kN	lb.	kN	in.	mm	
Heavy-Duty Plate Lip	42	1067	1.40	1.06	2,197	997	37,674	167.6	27,639	122.9	24,019	106.8	56.5	1435	5
	48	1219	1.60	1.22	2,361	1071	37,674	167.6	27,639	122.9	24,019	106.8	56.5	1435	6
	54	1372	1.80	1.39	2,509	1138	37,674	167.6	27,639	122.9	24,019	106.8	56.5	1435	6
Heavy-Duty High Capacity	24	610	0.90	0.70	1,767	801	35,844	159.4	26,709	118.8	23,312	103.7	62.5	1588	3
	30	760	1.20	0.92	2,012	913	35,844	159.4	26,709	118.8	23,312	103.7	62.5	1588	4
	36	914	1.50	1.13	2,135	968	35,844	159.4	26,709	118.8	23,312	103.7	62.5	1588	4
	42	1065	1.70	1.34	2,281	1035	35,844	159.4	26,709	118.8	23,312	103.7	62.5	1588	5
	48	1220	2.00	1.55	2,507	1137	35,844	159.4	26,709	118.8	23,312	103.7	62.5	1588	6
Severe-Duty Plate Lip	30	762	0.70	0.56	2,082	944	37,674	167.6	27,639	122.9	24,019	106.8	56.5	1435	4
	36	914	1.20	0.89	2,181	989	37,674	167.6	27,639	122.9	24,019	106.8	56.5	1435	4
	42	1067	1.10	0.81	2,347	1065	37,674	167.6	27,639	122.9	24,019	106.8	56.5	1435	5
Ditching	60	1525	3.90	3.00	1,563	709	45,271	201.4	29,243	130.1	25,224	112.2	47.0	1194	0

**Bucket Selection Guide\***

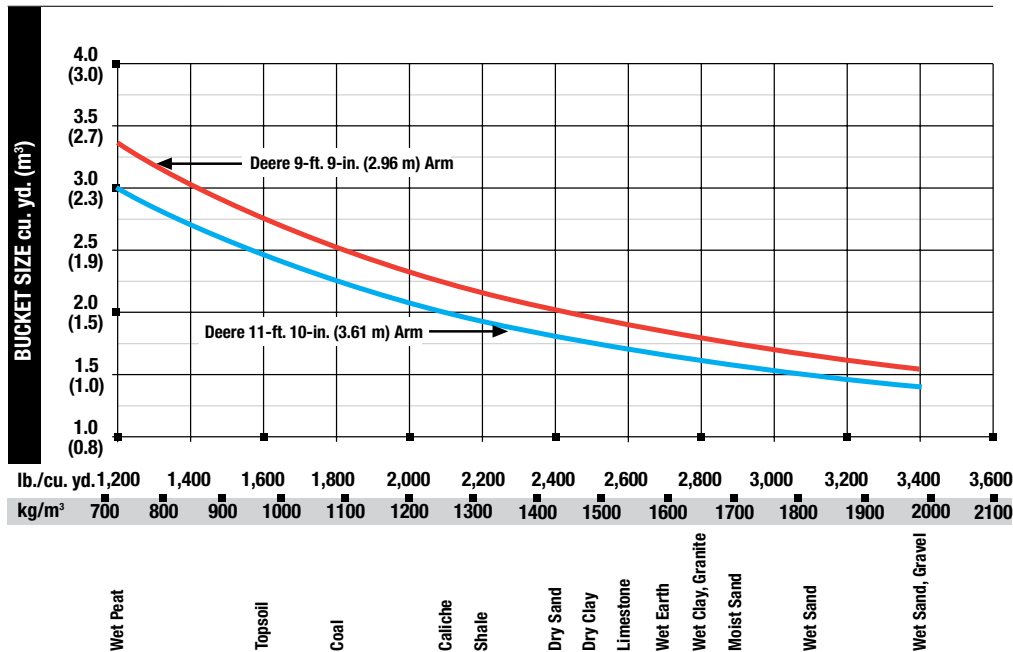

\*Contact your John Deere dealer for optimum bucket and attachment selections. These recommendations are for general conditions and average use. Does not include optional equipment such as thumbs or couplers. Larger buckets may be possible when using light materials, for flat and level operations, less compacted materials, and volume loading applications such as mass excavation applications in ideal conditions. Smaller buckets are recommended for adverse conditions such as off-level applications, rocks, and uneven surfaces. Bucket capacity indicated is SAE heaped.

# Specifications

## Engine 270D LC

Manufacturer and Model	John Deere 6068H
Non-Road Emission Standards	certified to EPA Tier 3 emissions
Net Power (ISO 9249)	188 hp (140 kW) @ 2,100 rpm
Cylinders	6
Displacement	415 cu. in. (6.8 L)
Off-Level Capacity	100% (45 deg.)
Aspiration	turbocharged, air-to-air charge air cooler

## Cooling

Cool-on-demand hydraulic-driven, suction-type fan with remote-mounted drive

## Powertrain

Two-speed propel with automatic shift

Maximum Travel Speed

Low	2.1 mph (3.3 km/h)
High	3.4 mph (5.5 km/h)

## Hydraulics

Open center, load sensing

**Main Pumps** 2 variable-displacement pumps

Maximum Rated Flow 2 x 62.3 gpm (2 x 236 L/m)

**Pilot Pump** one gear

Maximum Rated Flow 8.9 gpm (34 L/m)

Pressure Setting 566 psi (3900 kPa)

**System Operating Pressure**

Implement Circuits 4,980 psi (34 336 kPa)

Travel Circuits 4,980 psi (34 336 kPa)

Swing Circuits 4,700 psi (32 405 kPa)

Power Boost 5,260 psi (36 266 kPa)

**Controls** pilot levers, short stroke, low effort; hydraulic pilot controls with shutoff lever

## Cylinders

Heat-treated, chrome-plated, polished cylinder rods, hardened steel (replaceable bushings) pivot pins

	Bore	Rod Diameter	Stroke
Boom (2)	5.3 in. (135 mm)	3.7 in. (95 mm)	53.5 in. (1360 mm)
Arm (1)	5.9 in. (150 mm)	4.1 in. (105 mm)	65.3 in. (1659 mm)
Bucket (1)	5.3 in. (135 mm)	3.5 in. (90 mm)	42.1 in. (1070 mm)

## Electrical

Batteries 2 x 12 volt

Alternator Rating 80 amp

Work Lights 2 halogen (one mounted on boom, one mounted on frame)

## Undercarriage

Carrier Rollers (per side) 2

Track Rollers (per side) 8

Shoes, Triple Semi-Grouser (per side) 48

Drawbar Pull 55,336 lb. (25 100 kg)

Track

Adjustment hydraulic

Guides center

Chain sealed and lubricated

## Swing Mechanism

## 270D LC

Swing Speed	12.6 rpm
Swing Torque	56,896 lb.-ft. (77 140 Nm)

## Ground Pressure

32-in. (800 mm) Triple Semi-Grouser Shoes	5.84 psi (40.3 kPa)
---	---------------------

## Serviceability

### Refill Capacities

Fuel Tank	132 gal. (500 L)
Cooling System	8 gal. (29.9 L)
Engine Oil with Filter	7 gal. (24.6 L)
Hydraulic Tank	64 gal. (243 L)
Hydraulic System	74 gal. (280 L)

### Gearbox

Swing	7.5 qt. (7.1 L)
Propel (each)	6.5 qt. (6.2 L)
Pump Drive	1.2 qt. (1.1 L)

## Operating Weights

With Full Fuel Tank; 175-lb. (79 kg) Operator;  
 1.75-cu.-yd. (1.34 m<sup>3</sup>), 42-in. (1065 mm),  
 2,280-lb. (1034 kg) Heavy-Duty, High-  
 Capacity Bucket; 12-ft. 4-in. (3.75 m) Arm;  
 13,448-lb. (6100 kg) Counterweight; and  
 32-in. (800 mm) Triple Semi-Grouser Shoes . . . 65,588 lb. (29 750 kg)

### Optional Components

Undercarriage with Triple Semi-Grouser Shoes 32 in. (800 mm)	25,937 lb. (11 765 kg)
One-Piece Boom (with arm cylinder)	5,086 lb. (2307 kg)
Arm with Bucket Cylinder and Linkage	
10 ft. 2 in. (3.11 m)	3,102 lb. (1407 kg)
12 ft. 4 in. (3.75 m)	3,301 lb. (1497 kg)
Boom Lift Cylinders (2) Total Weight	1,089 lb. (494 kg)
1.75-cu.-yd. (1.34 m <sup>3</sup> ), 42-in. (1065 mm) Heavy-Duty, High-Capacity Bucket	2,280 lb. (1034 kg)
Counterweight (standard)	13,448 lb. (6100 kg)

## Operating Dimensions

	<i>Arm Length</i> 10 ft. 2 in. (3.11 m)	<i>Arm Length</i> 12 ft. 4 in. (3.75 m)
Arm Force with 32-in. (800 mm) Triple Semi-Grouser Shoes with Power Boost	29,517 lb. (131.3 kN)	25,978 lb. (115.6 kN)
Bucket Digging Force with 32-in. (800 mm) Triple Semi-Grouser Shoes with Power Boost	37,478 lb. (166.7 kN)	37,478 lb. (166.7 kN)
Lifting Capacity Over Front at Ground Level		
20-ft. (6.1 m) Reach with Power Boost	20,772 lb. (9422 kg)	19,727 lb. (8948 kg)
<b>A</b> Maximum Reach	35 ft. 2 in. (10.71 m)	37 ft. 0 in. (11.27 m)
<b>A'</b> Maximum Reach at Ground Level	34 ft. 6 in. (10.52 m)	36 ft. 5 in. (11.10 m)
<b>B</b> Maximum Digging Depth	23 ft. 9 in. (7.23 m)	25 ft. 10 in. (7.88 m)
<b>B'</b> Maximum Digging Depth at 8-ft. (2.44 m) Flat Bottom	23 ft. 2 in. (7.05 m)	25 ft. 4 in. (7.72 m)
<b>C</b> Maximum Cutting Height	33 ft. 8 in. (10.26 m)	34 ft. 4 in. (10.46 m)
<b>D</b> Maximum Dumping Height	24 ft. 0 in. (7.31 m)	24 ft. 8 in. (7.52 m)
<b>E</b> Minimum Swing Radius	12 ft. 10 in. (3.91 m)	12 ft. 10 in. (3.90 m)
<b>F</b> Maximum Vertical Wall	21 ft. 3 in. (6.48 m)	23 ft. 2 in. (7.05 m)
<b>G</b> Tail Swing Radius	9 ft. 8 in. (2.94 m)	9 ft. 8 in. (2.94 m)

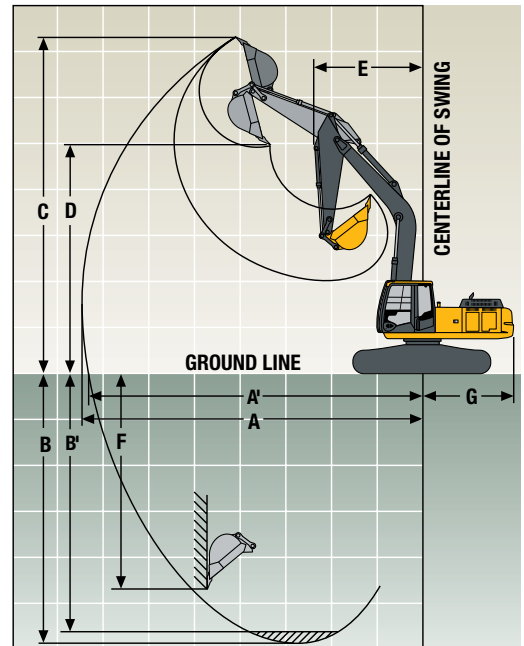



## Machine Dimensions

## 270D LC

	Arm Length 10 ft. 2 in. (3.11 m)	Arm Length 12 ft. 4 in. (3.75 m)
<b>A</b> Overall Length . . . . .	33 ft. 11 in. (10.34 m)	34 ft. 1 in. (10.39 m)
<b>B</b> Overall Height . . . . .	42 ft. 2 in. (12.85 m)	11 ft. 0 in. (3.35 m)
<b>C</b> Rear-End Length/Swing Radius . . . . .	9 ft. 8 in. (2.94 m)	
<b>D</b> Distance Between Idler/Sprocket Centerline. . . . .	13 ft. 3 in. (4.05 m)	
<b>E</b> Undercarriage Length. . . . .	16 ft. 2 in. (4.94 m)	
<b>F</b> Counterweight Clearance . . . . .	3 ft. 10 in. (1.18 m)	
<b>G</b> Upperstructure Width . . . . .	9 ft. 6 in. (2.89 m)	
<b>H</b> Cab Height . . . . .	10 ft. 2 in. (3.10 m)	
<b>I</b> Track Width with Triple Semi-Grouser Shoes. . . . .	24 in. (600 mm) / 28 in. (700 mm) / 32 in. (800 mm)	
<b>J</b> Gauge Width . . . . .	7 ft. 10 in. (2.39 m)	
<b>K</b> Ground Clearance. . . . .	20 in. (510 mm)	
<b>L</b> Overall Width with Triple Semi-Grouser Shoes		
24 in. (600 mm) . . . . .	9 ft. 10 in. (2.99 m)	
28 in. (700 mm) . . . . .	10 ft. 2 in. (3.09 m)	
32 in. (800 mm) . . . . .	10 ft. 6 in. (3.19 m)	

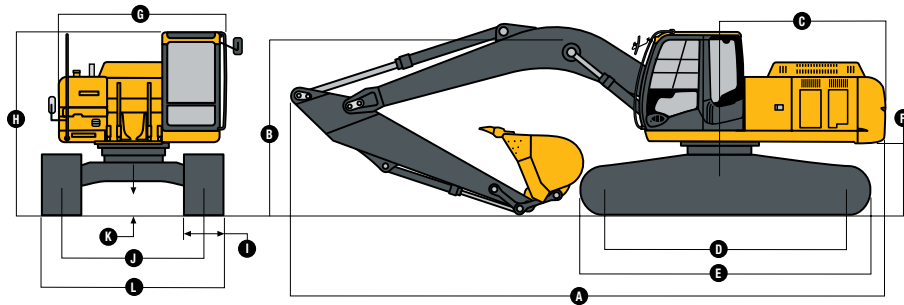

## Lift Capacities

**Boldface italic** type indicates hydraulic-limited capacities; lightface type indicates stability-limited capacities, in lb. (kg). Ratings are at bucket lift hook; using 1.75-cu.-yd. (1.34 m<sup>3</sup>) bucket; 32-in. (800 mm) triple semi-grouser shoes; standard counterweight; standard gauge; and situated on firm, uniform supporting surface. Figures do not exceed 87 percent of hydraulic capacities or 75 percent of weight needed to tip machine.

Load Point Height	10 ft. (3.05 m)		15 ft. (4.57 m)		20 ft. (6.10 m)		25 ft. (7.62 m)		30 ft. (9.14 m)	
	Over Front	Over Side	Over Front	Over Side	Over Front	Over Side	Over Front	Over Side	Over Front	Over Side
<i>With 10-ft. 2-in. (3.11 m) arm</i>										
20 ft. (6.10 m)							<b>10,106 (4584)</b>	<b>10,106 (4584)</b>		
15 ft. (4.57 m)					<b>11,759 (5334)</b>	<b>11,759 (5334)</b>	<b>10,992 (4986)</b>	10,981 (4981)	<b>8,349 (3787)</b>	7,778 (3528)
10 ft. (3.05 m)			<b>20,483 (9291)</b>	<b>20,483 (9291)</b>	<b>14,958 (6785)</b>	<b>14,958 (6785)</b>	<b>12,604 (5717)</b>	10,494 (4760)	<b>11,530 (5230)</b>	7,586 (3441)
5 ft. (1.52 m)			<b>27,306 (12 386)</b>	21,574 (9786)	<b>18,318 (8309)</b>	14,121 (6405)	<b>14,427 (6544)</b>	9,976 (4525)	<b>12,445 (5645)</b>	7,333 (3326)
Ground Line			<b>28,596 (12 971)</b>	20,732 (9404)	<b>20,772 (9422)</b>	13,442 (6097)	<b>15,959 (7239)</b>	9,564 (4338)	12,255 (5559)	7,117 (3228)
-5 ft. (-1.52 m)	<b>14,458 (6558)</b>	<b>14,458 (6558)</b>	<b>30,272 (13 731)</b>	20,589 (9339)	<b>21,874 (9922)</b>	13,133 (5957)	16,127 (7315)	9,337 (4235)	12,156 (5514)	7,026 (3187)
-10 ft. (-3.05 m)	<b>23,292 (10 565)</b>	<b>23,292 (10 565)</b>	<b>29,066 (13 184)</b>	20,761 (9417)	<b>21,566 (9782)</b>	13,131 (5956)	16,120 (7312)	9,332 (4233)		
-15 ft. (-4.57 m)	<b>29,502 (13 382)</b>	<b>29,502 (13 382)</b>	<b>25,803 (11 704)</b>	21,224 (9627)	<b>19,419 (8808)</b>	13,422 (6088)				
<i>With 12-ft. 4-in. (3.75 m) arm</i>										
25 ft. (7.62 m)							<b>8,490 (3851)</b>	<b>8,490 (3851)</b>		
20 ft. (6.10 m)							<b>8,629 (3914)</b>	<b>8,629 (3914)</b>	<b>5,983 (2714)</b>	<b>5,983 (2714)</b>
15 ft. (4.57 m)							<b>9,676 (4389)</b>	<b>9,676 (4389)</b>	<b>9,610 (4359)</b>	7,937 (3600)
10 ft. (3.05 m)			<b>17,040 (7729)</b>	<b>17,040 (7729)</b>	<b>13,188 (5982)</b>	<b>13,188 (5982)</b>	<b>11,405 (5173)</b>	10,668 (4839)	<b>10,525 (4774)</b>	7,681 (3484)
5 ft. (1.52 m)			<b>24,377 (11 057)</b>	22,291 (10 111)	<b>16,795 (7618)</b>	14,398 (6531)	<b>13,402 (6079)</b>	10,091 (4577)	<b>11,625 (5273)</b>	7,370 (3343)
Ground Line			<b>28,865 (13 093)</b>	20,935 (9496)	<b>19,727 (8948)</b>	13,563 (6152)	<b>15,194 (6892)</b>	9,601 (4355)	12,244 (5554)	7,097 (3219)
-5 ft. (-1.52 m)	<b>15,884 (7205)</b>	<b>15,884 (7205)</b>	<b>30,355 (13 769)</b>	20,481 (9290)	<b>21,411 (9712)</b>	13,102 (5943)	16,083 (7295)	9,284 (4211)	12,055 (5468)	6,923 (3140)
-10 ft. (-3.05 m)	<b>22,505 (10 208)</b>	<b>22,505 (10 208)</b>	<b>29,877 (13 552)</b>	20,490 (9294)	<b>21,738 (9860)</b>	12,972 (5884)	15,966 (7242)	9,178 (4163)	<b>10,393 (4714)</b>	6,920 (3139)
-15 ft. (-4.57 m)	<b>30,876 (14 005)</b>	<b>30,876 (14 005)</b>	<b>27,578 (12 509)</b>	20,820 (9444)	<b>20,490 (9294)</b>	13,131 (5956)	<b>15,518 (7039)</b>	9,328 (4231)		
-20 ft. (-6.10 m)	<b>30,942 (14 035)</b>	<b>30,942 (14 035)</b>	<b>22,518 (10 214)</b>	21,537 (9769)	<b>16,453 (7463)</b>	13,673 (6202)				

## Buckets

## 270D LC

A full line of buckets is offered to meet a wide variety of applications. Digging forces are with power boost. The buckets have an adjustable bushing for side clearance, with the exception of the ditching bucket. Tooth selection includes either the John Deere Fanggs®, Standard, Tiger, Twin Tiger, Abrasion panel, or Flare tooth, or the ESCO (Vertalok) Standard, Tiger, Twin Tiger, or Flare tooth. Replaceable cutting edges are available through John Deere parts. Optional side cutters add 6 inches (150 mm) to bucket widths. Capacities are SAE heaped ratings.

Bucket Type	Bucket Width		Bucket Capacity		Bucket Weight		Bucket Dig Force		Arm Dig Force 10 ft. 2 in. (3.11 m)		Arm Dig Force 12 ft. 4 in. (3.75 m)		Bucket Tip Radius		No. Teeth
	in.	mm	cu. yd.	m³	lb.	kg	lb.	kN	lb.	kN	lb.	kN	in.	mm	
Heavy-Duty Plate Lip	42	1067	1.38	1.06	2,197	997	41,474	184.5	30,508	135.7	26,740	118.9	56.5	1435	5
	48	1219	1.60	1.22	2,361	1071	41,474	184.5	30,508	135.7	26,740	118.9	56.5	1435	6
	54	1372	1.82	1.39	2,509	1138	41,474	184.5	30,508	135.7	26,740	118.9	56.5	1435	6
Heavy-Duty High Capacity	24	610	0.92	0.70	1,767	801	35,844	159.4	26,709	118.8	23,312	103.7	62.5	1588	3
	30	760	1.20	0.92	2,012	913	37,478	166.7	29,517	131.3	25,978	115.6	62.5	1588	4
	36	914	1.48	1.13	2,135	968	37,478	166.7	29,517	131.3	25,978	115.6	62.5	1588	4
	42	1065	1.75	1.34	2,281	1035	37,478	166.7	29,517	131.3	25,978	115.6	62.5	1588	5
	48	1220	2.03	1.55	2,507	1137	37,478	166.7	29,517	131.3	25,978	115.6	62.5	1588	6
Severe-Duty Plate Lip	30	762	0.95	0.73	2,082	944	41,474	184.5	30,508	135.7	26,740	118.9	56.5	1435	4
	36	914	1.16	0.89	2,181	989	41,474	184.5	30,508	135.7	26,740	118.9	56.5	1435	4
	42	1067	1.38	1.06	2,347	1065	41,474	184.5	30,508	135.7	26,740	118.9	56.5	1435	5
Ditching	60	1525	3.92	3.00	1,563	709	49,846	221.7	32,223	143.3	28,043	124.7	47.0	1194	0

## Bucket Selection Guide\*

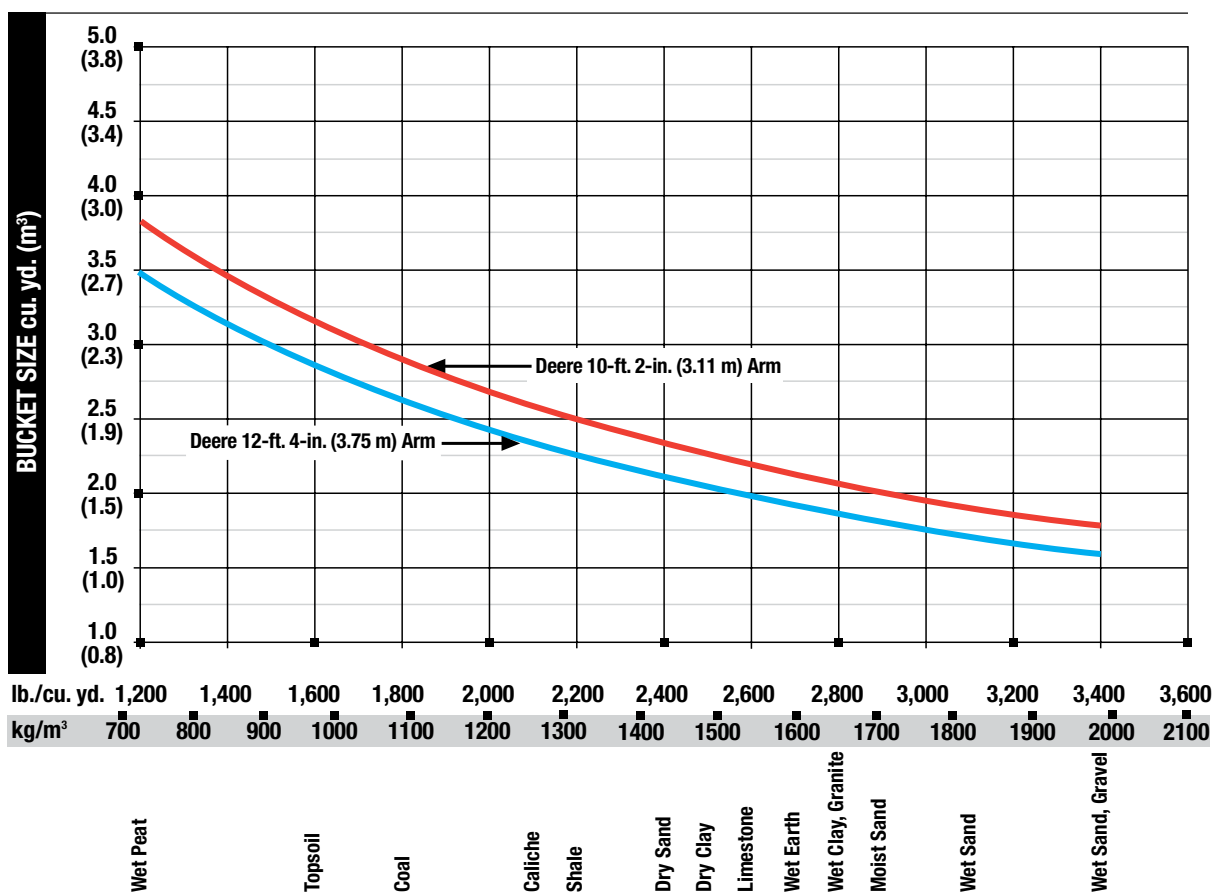

\*Contact your John Deere dealer for optimum bucket and attachment selections. These recommendations are for general conditions and average use. Does not include optional equipment such as thumbs or couplers. Larger buckets may be possible when using light materials, for flat and level operations, less compacted materials, and volume loading applications such as mass excavation applications in ideal conditions. Smaller buckets are recommended for adverse conditions such as off-level applications, rocks, and uneven surfaces. Bucket capacity indicated is SAE heaped.

## 240D LC / 270D LC EXCAVATORS

**Key:** ● Standard equipment ▲ Optional or special equipment

\*See your John Deere dealer for further information.

### 240D 270D Engine

- ● Certified to EPA Tier 3 emissions
- ● Auto-idle system
- ● Automatic belt tension device
- ● Batteries (two 12 volt), 180-min. reserve capacity
- ● Coolant recovery tank
- ● Dual-element dry-type air filter
- ● Electronic engine control
- ● Enclosed fan guard (conforms to SAE J1308)
- ● Engine coolant to -34°F (-37°C)
- ● Fuel filter with water separator
- ● Full-flow oil filter
- ● Turbocharger with charge air cooler
- ● Muffler, under hood, with vertical curved end exhaust stack
- ● Cool-on-demand hydraulic-driven fan
- ● Glow-plug start aid
- ● 500-hour engine-oil-change interval
- ● 100% (45 deg.) off-level capability
- ● Engine-oil-sampling valve
- ▲ ▲ Hydraulic fan reverser
- ▲ ▲ Engine coolant heater

### Hydraulic System

- ● Reduced-drift valve for boom down, arm in
- ● Auxiliary hydraulic valve section
- ● Spring-applied, hydraulically released automatic swing brake
- ● Auxiliary hydraulic-flow adjustments through monitor
- ● Auto power lift
- ● 5,000-hour hydraulic-oil-change interval
- ● Hydraulic-oil-sampling valve
- ▲ ▲ Auxiliary hydraulic lines
- ▲ ▲ Auxiliary pilot and electric controls
- ▲ ▲ Hydraulic filter restriction indicator kit
- ▲ ▲ Load-lowering control device
- ▲ ▲ Single-pedal propel control
- ▲ ▲ Control pattern change valve

### Undercarriage

- ● Planetary drive with axial piston motors
- ● Propel motor shields
- ● Spring-applied, hydraulically released automatic propel brake
- ● Track guides, front idler and center
- ● Two-speed propel with automatic shift
- ● Upper carrier rollers (2)
- ● Sealed and lubricated track chain
- ▲ ▲ Triple semi-grouser shoes, 28 in. (700 mm)

### 240D 270D Undercarriage (continued)

- ▲ ● Triple semi-grouser shoes, 32 in. (800 mm)
- ### Upperstructure
- ● Right- and left-hand mirrors
  - ● Vandal locks with ignition key: Cab door / Fuel cap / Service doors / Toolbox
  - ● Debris-screening side panel
  - ● Remote-mounted engine oil and fuel filters
- ### Front Attachments
- ● Centralized lubrication system
  - ● Dirt seals on all bucket pins
  - ● Less boom and arm
  - ● Oil-impregnated bushings
  - ● Reinforced resin thrust plates
  - ● Tungsten carbide thermal coating on arm-to-bucket joint
  - ▲ ▲ Arm, 9 ft. 9 in. (2.96 m)
  - ▲ ▲ Arm, 10 ft. 2 in. (3.11 m)
  - ▲ ▲ Arm, 11 ft. 10 in. (3.61 m)
  - ▲ ▲ Arm, 12 ft. 4 in. (3.75 m)
  - ▲ ▲ Attachment quick-couplers
  - ▲ ▲ Boom cylinder with plumbing to mainframe for less boom and arm
  - ▲ ▲ Bucket-to-arm clearance adjustable bushing (except ditching buckets)
  - ▲ ▲ Buckets: Ditching / Heavy duty / Heavy-duty high capacity / Severe-duty plate lip / Side cutters and teeth
  - ▲ ▲ Material clamps
  - ▲ ▲ Super-long fronts
- ### Operator's Station
- ● Adjustable independent control positions (levers-to-seat, seat-to-pedals)
  - ● AM/FM radio
  - ● Auto climate control/air conditioner, 20,000 Btu/hr. (5.9 kW) with heater and pressurizer
  - ● Built-in Operator's Manual storage compartment and manual
  - ● Cell-phone power outlet, 12 volt, 60 watt, 5 amp
  - ● Coat hook
  - ● Deluxe suspension cloth seat with 4-in. (100 mm) adjustable armrests
  - ● Floor mat
  - ● Front windshield wiper with intermittent speeds
  - ● Gauges (illuminated): Engine coolant / Fuel
  - ● Horn, electric
  - ● Hourmeter, electric
  - ● Hydraulic shutoff lever, all controls

### 240D 270D Operator's Station (continued)

- ● Hydraulic warm-up control
  - ● Interior light
  - ● Large cup holder
  - ● Machine Information Center (MIC)
  - ● Mode selectors (illuminated): Power modes – three / Travel modes – two with automatic shift / Work mode – one
  - ● Multifunction, color LCD monitor with: Diagnostic capability / Multiple-language capabilities / Maintenance tracking / Clock / Theft-deterrent system / System monitoring with alarm features: Auto-idle indicator, engine air cleaner restriction indicator light, engine check, engine coolant temperature indicator light with audible alarm, engine oil pressure indicator light with audible alarm, low-alternator-charge indicator light, low-fuel indicator light, fault code alert indicator, fuel-rate display, wiper-mode indicator, work-lights-on indicator, and work-mode indicator
  - ▲ ▲ Monitor system with alarm features: Hydraulic oil filter restriction indicator light
  - ● Motion alarm with cancel switch (conforms to SAE J994)
  - ● Power-boost switch on right console lever
  - ● Auxiliary hydraulic control switches in right console lever
  - ● Propel pedals and levers
  - ● SAE two-lever control pattern
  - ● Seat belt, 2 in. (51 mm), retractable
  - ▲ ▲ Seat belt, 3 in. (76 mm), non-retractable
  - ● Tinted glass
  - ● Transparent tinted overhead hatch
  - ● Hot/cold beverage compartment
  - ▲ ▲ Air-suspension heated seat
  - ▲ ▲ 24- to 12-volt D.C. radio convertors, 10 amp
  - ▲ ▲ Circulation fan
  - ▲ ▲ Protection screens for cab front, rear, and side
  - ▲ ▲ Window vandal protection covers
- ### Electrical
- ● 80-amp alternator
  - ● Blade-type multi-fused circuits
  - ● Positive terminal battery covers
  - ▲ ▲ Cab extension wiring harness
  - ● JDLink™ Ultimate wireless communication system with 3 years of service
- ### Lights
- ● Work lights: Halogen / One mounted on boom / One mounted on frame

## CONTROL OWNING AND OPERATING COSTS

Customer Personal Service (CPS) is part of John Deere's proactive, fix-before-fail strategy on machine maintenance that will help control costs, increase profits, and reduce stress. Included in this comprehensive lineup of ongoing programs and services are:

**Fluid analysis program** – tells you what's going on inside *all* of your machine's major components so you'll know if there's a problem *before* you see a decline in performance. Fluid analysis is included in most extended coverage and preventive-maintenance agreements.

**Component life-cycle data** – gives you vital information on the projected life span of components and lets you make informed decisions on machine maintenance by telling you approximately how many hours of use you can expect from an engine, transmission, or hydraulic pump. This information can be used to preempt catastrophic downtime by servicing major components at about 80 percent of their life cycle.

**Preventive Maintenance (PM) agreements** – give you a fixed cost for maintaining a machine for a given period of time. They also help you avoid downtime by ensuring that critical

maintenance work gets done right and on schedule. On-site preventive maintenance service performed where and when you need it helps protect you from the expense of catastrophic failures and lets you avoid waste-disposal hassles.

**Extended coverage** – gives you a fixed cost for machine repairs for a given period of time so you can effectively manage costs. Whether you work in a severe-service setting or just want to spread the risk of doing business, this is a great way to custom-fit coverage for your operation. And an extended coverage contract also travels well because it's backed by John Deere and is honored by *all* Deere construction dealers.

**Customer Support Advisors (CSAs)** – Deere believes the CSA program lends a *personal* quality to Customer Personal Service (CPS). Certified CSAs have the knowledge and skills for helping make important decisions on machine maintenance and repair. Their mission is to help you implement a plan that's right for *your* business and take the burden of machine maintenance off your shoulders.



JOHN DEERE

DKAX240270 Litho in U.S.A. (09-05)

Net engine power is with standard equipment including air cleaner, exhaust system, alternator, and cooling fan at test conditions specified per ISO9249. No derating is required up to 10,000-ft. (3050 m) altitude.

Specifications and design subject to change without notice. Wherever applicable, specifications are in accordance with SAE standards. Except where otherwise noted, these specifications are based on a unit with 42-in. (1067 mm) bucket, 32-in. (800 mm) triple semi-grouser shoes, full fuel tank, and 175-lb. (79 kg) operator; a 240D LC unit with 11,905-lb. (5400 kg) counterweight; and a 270D LC unit with 13,448-lb. (6100 kg) counterweight.

