



**JOHN DEERE**

6 METRIC TON

**D**

**EXCAVATOR**

**60D**





# Make it big with our largest compact.

Whether you're ready to take on bigger projects or looking for the right size excavator to fit a job, step up to a 60D. Deere's largest compact excavator, the new 60D is just right for landscaping, underground/utility, or site-development work. Like our other compacts, it excels in close quarters and is easy to trailer. But with its powerful dig forces, impressive digging depth,

and spacious, comfortable cab, this highly capable compact produces and feels more like a small mid-size excavator. And with a rugged interim Tier 4 engine and excellent serviceability, you'll get more done with low downtime and operating cost. Add it all up and you've got a compact excavator that will make a huge impact on your bottom line.



A spacious operating station with more legroom and a wider expanse of glass delivers the comfort and visibility you'd expect from a mid-size excavator in a compact machine.

Ultrareliable, fuel-efficient diesel meets rigid EPA Interim Tier 4 emissions standards. Power/Economy modes optimize power and fuel efficiency for digging applications.

Extended engine and hydraulic oil-service intervals increase uptime and reduce daily operating cost.

Three easy-to-open service doors provide wide-open access to service items. A tilt cab makes it easy to inspect and service hydraulic hoses or reach components.

| Specifications            | 60D          |
|---------------------------|--------------|
| Net Horsepower .....      | 54 hp        |
| Operating Weight .....    | 13,653 lb.   |
| Max. Ground Speed .....   | 2.8 mph      |
| Max. Digging Depth .....  | 12 ft. 4 in. |
| Max. Digging Force .....  | 6,969 lb.    |
| Max. Hydraulic Flow ..... | 38 gpm       |



# This workspace delivers plenty of both.

Climb aboard the 60D and you'll swear you're in a larger machine. The well-appointed cab is spacious and comfortable, with a wide expanse of tinted glass for virtually unobstructed visibility. And with nearly 7,000 pounds of digging force and as much as 13.5 feet of digging depth, the 60D digs like a backhoe or small mid-size excavator. But unlike

larger machines, it's highly maneuverable in close quarters and around obstacles. Standard equipped with backfill blade, wedge-style quick-coupler, and auxiliary hydraulics, with a host of options and attachments available, the 60D is highly versatile, too. So you can squeeze even more work out of tight spaces — without feeling cramped.



Standard equipped with independent swing boom, 360-degree rotation, and minimal tail swing, little gets in the way of the 60D.

The 60D transports easily between jobsites, making it perfect for landscaping and "dig-and-run" jobs.

For extra ability, a long-arm option adds additional digging depth and reach, along with counterweight to maintain stability.

Auto-idle automatically reduces engine speeds when hydraulics aren't in use, making the most of every precious drop of fuel.

Wide control spacing and a fully adjustable, high-back suspension seat ensure daylong comfort.

Go from backhoe- to excavator-style controls with just a twist of the wrist. Control-pattern selector valve is conveniently located in a compartment inside the cab and includes a sight glass that displays the selected pattern.

Ergonomic short-throw pilot levers provide smooth, predictable fingertip control with less effort.

Easy-to-read systems monitor provides vital operating info at a glance.

Convenient 12-volt port powers cell phones and other electronic devices. There's also a large cup holder, seat pocket for documents, and a storage compartment.

Automatic, high-velocity bi-level climate-control system with automotive-style adjustable louvers helps keep the glass clear and the cab comfortable.

Noise-reducing muffler and isochronous high-idle speed help keep things quiet. Silicone-filled cab mounts further reduce noise, vibration, and operator fatigue.

Power/Economy modes allow you to tailor the engine speed to the application. Use P Mode to dial in the higher engine speeds needed for most general digging work. For light digging work, push a button to select E Mode and quickly reduce engine speed and noise, while improving fuel efficiency.

1. High sideboards are no problem for this excavator. Plenty of lift height and reach make truck loading easy.
2. Standard wedge-style coupler accommodates a wide variety of attachments, such as breakers and augers.
3. Rubber tracks traverse virtually any terrain and are even welcome on finished surfaces. For increased life in tough conditions, opt for steel tracks.



Wet-disk swing brake delivers long-term maintenance-free performance.

Spring-applied, hydraulically released parking brake automatically engages when you release the control levers, for improved safety.

Heavy-duty shields deflect material and impacts, protecting the propel motors and boom and blade cylinders.

Unique tungsten-carbide thermal coating creates an extremely wear-resistant surface on the all-important bucket-to-arm joint that won't compromise joint strength.

Oil-impregnated boom, arm, and bucket bushings enhance durability and extend grease intervals bucket-to-arm.

O-ring face-seal hydraulic fittings virtually eliminate aggravating and costly oil leaks.

Extended hydraulic oil, engine oil, and grease intervals save time and money.

Rubber tracks feature a unique steel core that resists cracking.

One-piece swing-post design improves structural integrity of digging components.

Rigid, reinforced D-channel side frames resist impact, providing maximum cab and component protection.

Box-section track frames, thick-plate X-frame, and large swing bearing deliver rock-solid durability.



1. Wear-resistant hoses are routed where they're protected and secured to prevent excessive tension. Split hose design simplifies replacement.



2. Heavy-duty welded x-frame provides a solid, stable platform that resists material buildup.



3. Operator station tilts forward, for quick and easy access to internal components, or to inspect and service hydraulic hoses.





# Nothing lasts like a Deere.

Like our larger excavators, the 60D delivers big-time reliability. In fact, all of our D-Series Compact Excavators share many of the same durability features that make our big excavators so reliable. Unique features such

as tungsten carbide-coated surfaces and powdered-metal oil-impregnated boom, arm, and bucket bushings help ensure unsurpassed uptime. When you know how they're built, you'll run a Deere.

Oil cooler and radiator are arranged in parallel, making cleanout using an air blower a breeze.

Large, easy-to-open doors provide quick access to service items. Lube banks, filters, and checkpoints are grouped for added convenience.

Large fuel tanks and 500- and 2,000-hour engine and hydraulic oil-service intervals enable these excavators to work longer between stops for scheduled service.

Variable-speed, direct-drive fan saves fuel and reduces noise.

Easy-access vertical spin-on filters allow quick and clean changes.

Convenient lube/maintenance chart helps ensure that nothing gets overlooked.





# Stretches service intervals and your dollars even further.

If there's a way to increase uptime, reduce daily operating costs, and simplify maintenance, we've implemented it in the 60D. Remote-mounted vertical oil and fuel filters and extended engine and hydraulic oil-change intervals help minimize maintenance and cost. Three easy-to-open doors provide wide-open

access for all maintenance checks and service. If necessary, the operator station tilts forward, providing quick, wide-open access to check hydraulic hoses or components. Plus industry-leading parts and service are also within easy reach at more than 800 John Deere locations coast to coast.

1. Easy-to-read gauges provide fuel level and engine coolant temperatures at a glance.

2. Routine checkpoints, such as engine oil level, are easily accessible from ground level.

3. With the cab tilted, the hydraulic control valve and hoses are easily accessible.

4. See-through coolant reservoir and hydraulic fluid sight gauge let you check levels at a glance.

5. A simple grease gun and a wrench are all that are needed to quickly adjust track tension.

6. Nobody backs you better than the 800-plus John Deere CWP dealers throughout North America.



# Specifications

60D

## Engine 60D

---

Manufacturer and Model . . . . . Yanmar 4TNV98  
Non-Road Emission Standards . . . . . certified to EPA interim Tier 4 emissions  
Displacement . . . . . 194 cu. in. (3.2 L)  
Net Power (ISO9249) . . . . . 54 hp (40.5 kW) @ 2,000 rpm

## Powertrain

---

Each track independently driven by hydrostatic axial-piston motor connected to 2-stage planetary gear-reduction box  
Travel Speed (maximum)  
Low . . . . . 1.6 mph (2.5 km/h)  
High . . . . . 2.8 mph (4.5 km/h)

## Hydraulics

---

Closed center, load sensing  
**Main Pumps** . . . . . one variable-displacement pump  
Maximum Rated Flow . . . . . 38 gpm (144 L/m)  
**Pilot Pump** . . . . . one gear  
Maximum Rated Flow . . . . . 2.7 gpm (10 L/m)  
Auxiliary Flow . . . . . 22.5 gpm (85 L/m)  
**Controls** . . . . . hydraulic pilot-operated for boom, arm, bucket, swing, boom swing, blade, travel, and auxiliary functions

## Upperstructure

---

Counterweight  
Standard . . . . . 1,676 lb. (760 kg)  
Additional . . . . . 573 lb. (260 kg)  
Independent Swing Boom  
Left . . . . . 80 deg.  
Right . . . . . 60 deg.  
Tail Swing . . . . . short

## Swing Mechanism

---

Swing Brake . . . . . spring applied, hydraulically released, automatic  
Swing Speed . . . . . 9.5 rpm

## Ground Pressure

---

Standard Arm/Standard Counterweight . . . . 4.93 psi (34 kPa)  
Long Arm/Additional Counterweight . . . . . 5.16 psi (36 kPa)

## Serviceability

---

**Refill Capacities**  
Fuel Tank . . . . . 32 gal. (120 L)  
Engine Oil with Filter . . . . . 3 gal. (11.2 L)  
Hydraulic System . . . . . 11 gal. (41 L)

## Operating Weights

60D

With Full Fuel Tank, 175-lb. (79 kg) Operator, and 6.8-cu.-ft. (0.19 m<sup>3</sup>) Bucket

|   |                      |
|---|----------------------|
| 4-ft. 11-in. (1.5 m) Standard Arm, 1,676-lb. (760 kg) Standard Counterweight, and Rubber Tracks . . . . . | 13,653 lb. (6193 kg) |
| 4-ft. 11-in. (1.5 m) Standard Arm, 1,676-lb. (760 kg) Standard Counterweight, and Steel Tracks . . . . .  | 13,774 lb. (6248 kg) |
| 6-ft. 1-in. (1.85 m) Long Arm, 573-lb. (260 kg) Additional Counterweight, and Rubber Tracks . . . . .     | 14,299 lb. (6486 kg) |
| 6-ft. 1-in. (1.85 m) Long Arm, 573-lb. (260 kg) Additional Counterweight, and Steel Tracks . . . . .      | 14,420 lb. (6541 kg) |

## Operating Dimensions

|   | Arm Length<br>4 ft. 11 in. (1.5 m) | Arm Length<br>6 ft. 1 in. (1.85 m) |
|---|------------------------------------|------------------------------------|
| Arm Breakout Force . . . . .              | 6,969 lb. (31 kN)                  | 6,070 lb. (27 kN)                  |
| Bucket Breakout Force . . . . .           | 9,217 lb. (41 kN)                  | 9,217 lb. (41 kN)                  |
| <b>A</b> Maximum Digging Reach . . . . .  | 20 ft. 5 in. (6.23 m)              | 21 ft. 6 in. (6.56 m)              |
| <b>B</b> Maximum Digging Depth . . . . .  | 12 ft. 4 in. (3.77 m)              | 13 ft. 6 in. (4.12 m)              |
| <b>C</b> Maximum Digging Height . . . . . | 19 ft. 7 in. (5.96 m)              | 20 ft. 4 in. (6.19 m)              |
| <b>D</b> Maximum Dumping Height . . . . . | 13 ft. 8 in. (4.17 m)              | 14 ft. 5 in. (4.40 m)              |
| <b>E</b> Minimum Swing Radius . . . . .   | 8 ft. 1 in. (2.47 m)               | 8 ft. 5 in. (2.56 m)               |
| <b>F</b> Transport Length . . . . .       | 18 ft. 11 in. (5.76 m)             | 19 ft. 0 in. (5.79 m)              |
| <b>G</b> Tail Swing Radius . . . . .      | 4 ft. 3 in. (1.30 m)               | 4 ft. 8 in. (1.42 m)               |

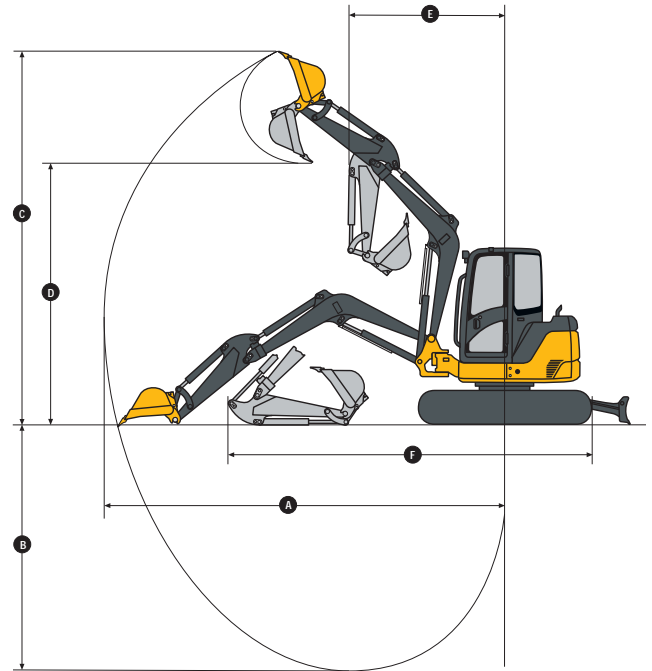

## Machine Dimensions

|  |                      |
|--|----------------------|
| Blade Width . . . . .                              | 6 ft. 7 in. (2.00 m) |
| Blade Height . . . . .                             | 1 ft. 4 in. (0.42 m) |
| <b>H</b> Overall Height . . . . .                  | 8 ft. 5 in. (2.56 m) |
| <b>I</b> Track Width . . . . .                     | 1 ft. 4 in. (0.40 m) |
| <b>J</b> Undercarriage Width . . . . .             | 6 ft. 7 in. (2.00 m) |
| <b>K</b> Ground Clearance . . . . .                | 1 ft. 1 in. (0.34 m) |
| <b>L</b> Engine Cover Height . . . . .             | 5 ft. 2 in. (1.57 m) |
| <b>M</b> Maximum Blade Lift Above Ground . . . . . | 1 ft. 6 in. (0.45 m) |
| <b>N</b> Maximum Blade Drop Below Ground . . . . . | 1 ft. 3 in. (0.39 m) |
| <b>O</b> Sprocket Center To Idler Center . . . . . | 6 ft. 6 in. (1.99 m) |
| <b>P</b> Track Length . . . . .                    | 8 ft. 2 in. (2.50 m) |
| <b>Q</b> Counterweight Clearance . . . . .         | 2 ft. 0 in. (0.62 m) |
| <b>R</b> Overall Width . . . . .                   | 6 ft. 7 in. (2.00 m) |

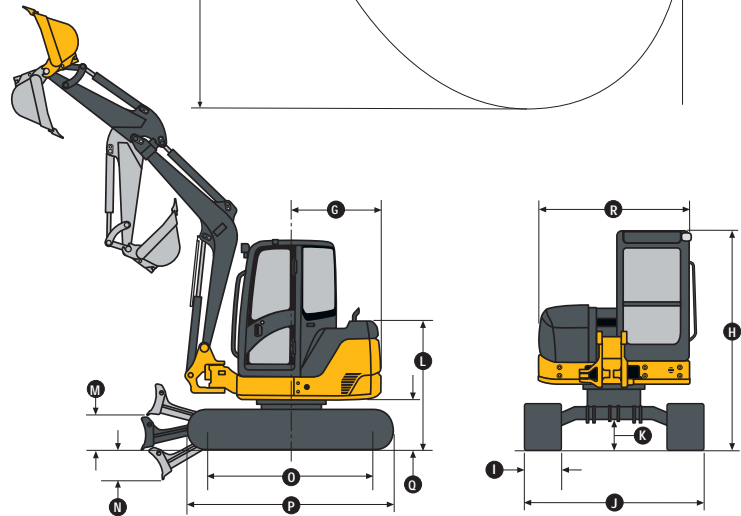

## Lift Capacities

|  | 4-ft. 11-in. (1.5 m) standard arm, 1,676-lb. (760 kg) standard counterweight, and rubber tracks | 4-ft. 11-in. (1.5 m) standard arm, 1,676-lb. (760 kg) standard counterweight, and steel tracks | 6-ft. 1-in. (1.85 m) long arm, 573-lb. (260 kg) additional counterweight, and rubber tracks | 6-ft. 1-in. (1.85 m) long arm, 573-lb. (260 kg) additional counterweight, and steel tracks |
|--|---|--|---|--|
| Ground Level at 10-ft. (3.05 m) Radius |   |  |   |  |
| Lifting Over Front . . . . .           | 5,954 lb. (2701 kg)   | 5,954 lb. (2701 kg)  | 7,802 lb. (3539 kg)   | 7,802 lb. (3539 kg)  |
| Lifting Over Side . . . . .            | 2,990 lb. (1356 kg)   | 3,050 lb. (1383 kg)  | 3,372 lb. (1530 kg)   | 3,432 lb. (1557 kg)  |

## 60D EXCAVATOR

Key: ● Standard equipment ▲ Optional or special equipment

See your John Deere dealer for further information.

### 60D Engine

- Certified to EPA interim Tier 4 emissions
- Engine coolant to -34 deg. F (-37 deg. C)
- Engine preheater
- Fan guard
- Fuel/water separator
- Full-flow oil filter
- Isolation mounted
- Key start switch with electric fuel shutoff
- Single dry-type air filter
- Under-hood muffler

### Hydraulic System

- Auxiliary function foot control
- Auxiliary hydraulic lines with quick-couplers to end of boom
- Auxiliary return-flow selector valve
- Axial-piston swing motor
- Boom-swing foot control
- Excavator-to-backhoe control pattern change valve
- Closed-center load sensing with one variable-displacement pump and one fixed-gear pump
- Hydraulic pilot-operated controls for boom, arm, bucket, swing, boom swing, blade, travel, and auxiliary functions
- Wet-disc swing brake

### Undercarriage

- Planetary final drive
- Propel motor shield
- Rubber track, 16 in. (400 mm)

### 60D Undercarriage (continued)

- Two-speed axial-piston propel motors
- ▲ Steel track, 16 in. (400 mm) with triple semi-grousers
- ▲ Rubber crawler pad, 16 in. (400 mm)

### Upperstructure

- 360-deg. rotation
- Counterweight, 1,676 lb. (760 kg)
- Hinged service-access doors
- One-piece airtight floor
- Independent-swing boom (80-deg. left, 60-deg. right)
- Toolbox
- ROPS/TOPS/FOPS (cab) with air conditioning and heater
- Vandal protection for service doors, fuel cap, and toolbox
- Reduced-tail-swing configuration

### Front Attachments

- Arm, 4 ft. 11 in. (1.50 m)
- ▲ Long arm, 6 ft. 1 in. (1.85 m), includes additional 573-lb. (260 kg) counterweight
- Articulation hose shield
- Backfill blade, 6 ft. 7 in. (2.00 m)
- Boom, 9 ft. 9 in. (2.965 m)
- Mechanical quick-coupler
- ▲ Augers: Planetary / Chain drive / Bits / Bit adapters
- ▲ Clamp
- ▲ Hammers: Points / Tools
- ▲ Quick-coupler buckets: Bucket teeth / Ditching / Heavy-duty

### 60D Operator's Station

- Horn
- Hour meter
- Instrumentation lights
- Monitor system: Preheat indicator / Engine oil pressure indicator / Alternator voltage indicator / Fuel gauge and fuel level indicator / Engine coolant temperature gauge and engine coolant temperature indicator / Hour meter / Work lights indicator
- Motion alarm with cancel switch
- Propel levers and foldable pedals
- Two travel speeds with automatic shifting
- Seat belt, 2 in. (51 mm), retractable
- Suspension seat (cloth)
- ▲ Front screen
- ▲ Rear secondary exit kit

### Electrical

- 12-volt accessory outlet
- 50-amp alternator
- Low-maintenance battery
- Blade-type multi-fused circuits
- Positive terminal battery covers
- ▲ JDLink™ wireless communication system

### Lights

- Work lights: Halogen / One mounted on operator's station / One mounted on boom
- Work lights switch

## CONTROL OWNING AND OPERATING COSTS

Customer Personal Service (CPS) is part of John Deere's proactive, fix-before-fail strategy on machine maintenance that will help control costs, increase profits, and reduce stress. Included in this comprehensive lineup of ongoing programs and services are:

**Fluid analysis program** – tells you what's going on inside *all* of your machine's major components so you'll know if there's a problem *before* you see a decline in performance. Fluid analysis is included in most extended coverage and preventive-maintenance agreements.

**Preventive Maintenance (PM) agreements** – give you a fixed cost for maintaining a machine for a given period of time. They also help you avoid downtime by ensuring that critical maintenance work gets done right and on schedule. On-site preventive maintenance service performed where and when you need it helps protect you from the expense of catastrophic failures and lets you avoid waste-disposal hassles.

**Extended warranty coverage** – gives you a fixed cost for machine repairs for a given period of time so you can effectively manage expenses. Whether you work in a severe-service setting, or you just want to spread the risk of doing business, this is a great way to custom-fit coverage to your operation. Choose from engine, powertrain, powertrain with hydraulics, or full-machine two-year/2,000-hour or three-year/3,000-hour coverage. An extended coverage contract travels well because it's backed by John Deere and honored at *all* John Deere Commercial Worksite Products dealers. What's more, extended coverage is fully transferable at no extra charge, so it adds value at trade-in.

**Customer Support Advisors (CSAs)** – Deere believes the CSA program lends a *personal* quality to Customer Personal Service (CPS). Certified CSAs have the knowledge and skills for helping make important decisions on machine maintenance and repair. Their mission is to help you implement a plan that's right for *your* business and take the burden of machine maintenance off your shoulders.



JOHN DEERE

DKA60DCWP Litho in U.S.A. (08-06)

Net engine power is with standard equipment including air cleaner, exhaust system, alternator, and cooling fan at test conditions specified per ISO9249. No derating is required up to 10,000-ft. (3050 m) altitude.

These machines are not equipped with spark-arrestor mufflers. Usage in forestry applications is not recommended.

Specifications and design subject to change without notice. Wherever applicable, specifications are in accordance with SAE standards. Except where otherwise noted, these specifications are based on a unit with standard equipment, 6.8-cu.-ft. (0.19 m<sup>3</sup>) bucket, 16-in. (400 mm) rubber tracks, 1,676-lb. (760 kg) counterweight, 4-ft. 11-in. (1.50 m) arm, full fuel tank, and 175-lb. (79 kg) operator.

