

17ZTS 27ZTS 35ZTS 50ZTS

CONSTRUCTION EQUIPMENT

Engine	17ZTS	27ZTS	35ZTS	50ZTS
Make.....	Isuzu	Isuzu	Isuzu	Isuzu
Model.....	3YB1	3LD1	3LD1	4LE1
Fuel.....	diesel	diesel	diesel	diesel
Cooling.....	liquid	liquid	liquid	liquid
Displacement.....	46.4 cu. in. (0.76 L)	91.5 cu. in. (1.50 L)	91.5 cu. in. (1.50 L)	133 cu. in. (2.18 L)
Horsepower.....	12.3 hp (9.2 kW) @ 2,300 rpm	22.0 hp (16.2 kW) @ 2,450 rpm	29.0 hp (21.6 kW) @ 2,450 rpm	38.0 hp (27.9 kW) @ 2,000 rpm

Performance

Operating weight.....	3,814 lb. (1730 kg)	6,360 lb. (2885 kg)	7,782 lb. (3530 kg)	10,565 lb. (4792 kg)
Maximum travel speed				
Low.....	1.20 mph (2.0 km/h)	1.50 mph (2.4 km/h)	1.98 mph (3.2 km/h)	1.56 mph (2.5 km/h)
High.....	2.50 mph (4.0 km/h)	2.94 mph (4.7 km/h)	2.80 mph (4.5 km/h)	2.80 mph (4.5 km/h)
Hydraulic pumps.....	3 total	3 total	3 total	3 total
Type.....	2 piston and 1 gear	2 piston and 1 gear	2 piston and 1 gear	2 piston and 1 gear
Total capacity				
Piston.....	4.4 gpm (16.80 L/min.) x 2	7.8 gpm (29.40 L/min.) x 2	11.0 gpm (41.63 L/min.) x 2	10.9 gpm (41.40 L/min.) x 2
Gear.....	3.3 gpm (12.50 L/min.)	4.2 gpm (15.90 L/min.)	6.8 gpm (25.70 L/min.)	7.6 gpm (28.60 L/min.)
Auxiliary flow.....	8.9 gpm (33.60 L/min.)	12.0 gpm (45.40 L/min.)	22.0 gpm (83.30 L/min.)	21.9 gpm (82.80 L/min.)
Fuel tank capacity.....	6.6 gal. (25.0 L)	10.5 gal. (40.0 L)	10.5 gal. (40.0 L)	13.2 gal. (50.0 L)
Hydraulic tank capacity.....	7.4 gal. (28.0 L)	7.9 gal. (30.0 L)	7.9 gal. (30.0 L)	11.8 gal. (45.0 L)
Ground pressure (with rubber track).....	29.9 kPa (4.34 psi)	29.1 kPa (4.22 psi)	31.2 kPa (4.52 psi)	26.4 kPa (3.82 psi)

Working Range

Transport length.....	12 ft. 0 in. (3660 mm)	13 ft. 11.0 in. (4260 mm)	15 ft. 5.0 in. (4720 mm)	17 ft. 5.0 in. (5325 mm)
Arm length.....	3 ft. 1.0 in. (930 mm)	3 ft. 10.0 in. (1170 mm)	4 ft. 2.0 in. (1265 mm)	4 ft. 5.0 in. (1340 mm)
A Maximum digging height.....	11 ft. 7.0 in. (3530 mm)	13 ft. 11.0 in. (4240 mm)	14 ft. 8.0 in. (4470 mm)	16 ft. 11.0 in. (5145 mm)
B Maximum dumping height.....	8 ft. 4.0 in. (2550 mm)	9 ft. 10.0 in. (3000 mm)	10 ft. 2.0 in. (3100 mm)	11 ft. 6.4 in. (3515 mm)
C Maximum digging depth.....	7 ft. 3.0 in. (2200 mm)	8 ft. 8.0 in. (2650 mm)	10 ft. 4.0 in. (3150 mm)	11 ft. 9.7 in. (3600 mm)
D Maximum digging reach.....	12 ft. 11.0 in. (3950 mm)	15 ft. 5.0 in. (4700 mm)	17 ft. 1.0 in. (5210 mm)	19 ft. 1.0 in. (5816 mm)
E Minimum front swing radius.....	5 ft. 5.0 in. (1655 mm)	6 ft. 8.0 in. (2040 mm)	7 ft. 9.0 in. (2360 mm)	8 ft. 9.0 in. (2655 mm)
Bucket breakout force.....	3,042 lb. (1380 kg)	5,071 lb. (2300 kg)	6,173 lb. (2800 kg)	8,378 lb. (3800 kg)
Arm breakout force.....	2,138 lb. (970 kg)	3,329 lb. (1510 kg)	4,299 lb. (1950 kg)	5,512 lb. (2500 kg)

Lift Capacities

Ground level at 10-ft. (3.05 m) radius				
Over front, blade down.....	864 lb. (392 kg)*	2,239 lb. (1015 kg)*	2,994 lb. (1358 kg)*	5,480 lb. (2485 kg)*
Over side.....	470 lb. (213 kg)	1,010 lb. (458 kg)	1,547 lb. (701 kg)	2,268 lb. (1028 kg)

*Limited by hydraulics.

Drive

Each track is independently driven by a hydrostatic axial-piston motor connected to a two-stage planetary gear reduction box

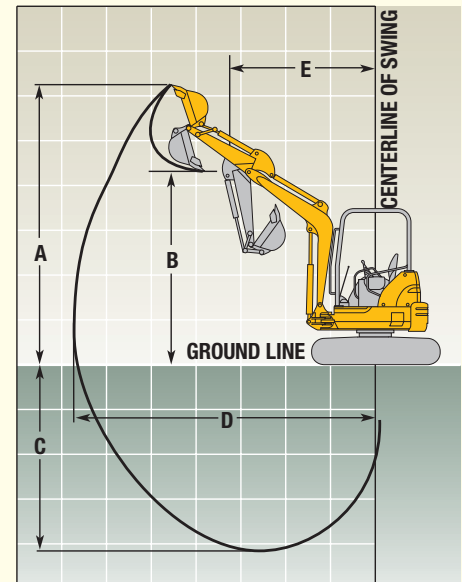

Swing System	17zTS	27zTS	35zTS	50zTS
Swing speed	8.6 rpm	8.1 rpm	8.8 rpm	7.4 rpm
Boom swing				
Left	65 degrees	66 degrees	66 degrees	60 degrees
Right	50 degrees	66 degrees	86 degrees	80 degrees
Blade				
Blade width	4 ft. 5.0 in. (1350 mm)	5 ft. 1.0 in. (1530 mm)	5 ft. 7.0 in. (1700 mm)	6 ft. 6.7 in. (2000 mm)
Blade height	10.5 in. (270 mm)	13.8 in. (350 mm)	13.8 in. (350 mm)	14.8 in. (375 mm)
Dimensions				
F Upperstructure width	4 ft. 5.0 in. (1350 mm)	4 ft. 11.0 in. (1490 mm)	4 ft. 11.0 in. (1490 mm)	6 ft. 1.0 in. (1865 mm)
G Overall height	7 ft. 7.0 in. (2320 mm)	8 ft. 4.0 in. (2550 mm)	8 ft. 5.0 in. (2560 mm)	8 ft. 7.0 in. (2610 mm)
H Track width	9.0 in. (230 mm)	12.0 in. (300 mm)	12.0 in. (300 mm)	16.0 in. (400 mm)
I Undercarriage width	4 ft. 5.0 in. (1350 mm)	5 ft. 1.0 in. (1550 mm)	5 ft. 9.0 in. (1740 mm)	6 ft. 7.0 in. (2000 mm)
J Ground clearance	9.4 in. (240 mm)	1 ft. 1.8 in. (325 mm)	1 ft. 1.8 in. (325 mm)	1 ft. 1.2 in. (335 mm)
K Tail swing radius	2 ft. 3.0 in. (675 mm)	2 ft. 7.0 in. (775 mm)	2 ft. 10.0 in. (870 mm)	3 ft. 3.4 in. (1000 mm)
L Engine cover height	4 ft. 2.0 in. (1265 mm)	4 ft. 11.0 in. (1510 mm)	5 ft. 0 in. (1530 mm)	5 ft. 2.0 in. (1580 mm)
M Maximum blade lift above ground	10.7 in. (275 mm)	1 ft. 1.0 in. (330 mm)	1 ft. 3.0 in. (380 mm)	1 ft. 6.0 in. (450 mm)
N Maximum blade drop below ground	9.8 in. (250 mm)	1 ft. 2.6 in. (370 mm)	1 ft. 4.0 in. (400 mm)	1 ft. 7.0 in. (470 mm)
O Sprocket center to idler center	4 ft. 0 in. (1210 mm)	4 ft. 11.0 in. (1500 mm)	5 ft. 7.0 in. (1700 mm)	6 ft. 5.0 in. (1955 mm)
P Track length	5 ft. 2.0 in. (1570 mm)	6 ft. 4.0 in. (1920 mm)	6 ft. 11.0 in. (2120 mm)	8 ft. 1.0 in. (2460 mm)
Q Counterweight clearance	1 ft. 6.0 in. (455 mm)	1 ft. 9.0 in. (540 mm)	1 ft. 10.0 in. (550 mm)	2 ft. 0 in. (600 mm)

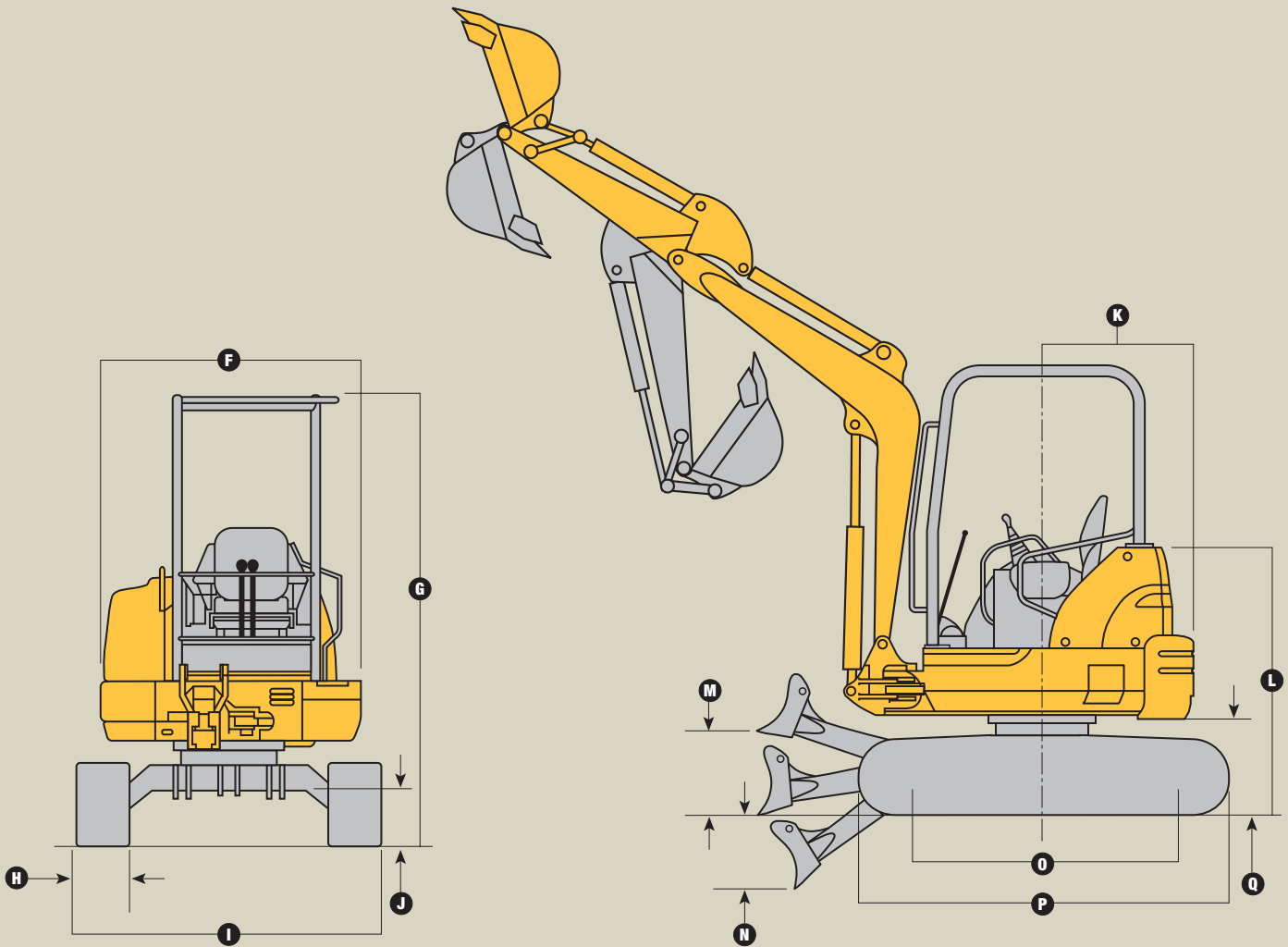

17ZTS / 27ZTS / 35ZTS / 50ZTS Compact Excavators

Key: ● Standard equipment ▲ Optional or special equipment

See your John Deere dealer for further information.

17	27	35	50	Engine	17	27	35	50	Upperstructure	17	27	35	50	Front Attachments (continued)
●	●	●	●	Engine coolant to -34°F (-37°C)	●	●	●	●	360-degree rotation	▲	▲	▲	▲	Augers: Planetary / Chain drive / Bits / Bit adapters
●	●	●	●	Engine preheater	●	●			Counterweight, 672 lb. (305 kg)					Clamp
●	●	●	●	EPA-certified off-road diesel			●		Counterweight, 1,225 lb. (556 kg)	▲	▲	▲	▲	Grapple
●	●	●	●	Fan guard				●	Counterweight, 1,323 lb. (600 kg)	▲	▲	▲	▲	Hammers: Points / Tools
●	●	●	●	Fuel/water separator	●	●	●	●	Hinged service-access doors	▲	▲	▲	▲	Quick-coupler buckets: Bucket teeth / Ditching / Heavy-duty
●	●	●	●	Full-flow oil filter	●				Independent-swing boom 65-degree left, 50-degree right)					Operator's Station
●	●	●	●	Isolation mounted					Independent-swing boom 66-degree left, 66-degree right)	●	●	●	●	Horn
●	●	●	●	Key start switch with electric fuel shutoff			●	●	Independent-swing boom 60-degree left, 80-degree right)	●	●	●	●	Hourmeter
●	●	●	●	Single dry-type air filter				●	Independent-swing boom 60-degree left, 80-degree right)	●	●	●	●	Instrumentation lights
●	●	●	●	Under-hood muffler					Toolbox	●	●	●	●	Monitor system with: Alternator charge warning light / Engine coolant temperature / Engine oil pressure warning light / Engine preheat indicator / Fuel gauge / Work lights on indicator
				Hydraulic System	●	●	●	●	TOPS/FOPS canopy					Motion alarm with cancel switch
●	●	●	●	Auxiliary function foot control	●	●	●	●	Vandal locks for service doors, fuel cap, toolbox, and monitor panel	●	●	●	●	Propel pedals and levers
●	●	●	●	Auxiliary hydraulic lines with quick-couplers to end of arm	●	●	●	●	Zero-tail-swing configuration					Two travel modes with foot selection switch
●	●	●	●	Auxiliary return-flow selector valve					Front Attachments	●	●	●	●	Seat belt, 2 in. (51 mm), retractable
●	●	●	●	Axial-piston swing motor	●				Arm, 3 ft. 1.0 in. (930 mm)	●	●	●	●	Vinyl seat with fore/aft adjustment
●	●	●	●	Boom-swing foot control		●			Arm, 3 ft. 10.0 in. (1170 mm)	▲	▲	▲	▲	Cab with heater
●	●	●	●	Excavator-to-backhoe control pattern change valve			●		Arm, 4 ft. 2.0 in. (1265 mm)	▲	▲	▲	▲	Front screen
●	●	●	●	Open center with two variable-displacement pumps and one fixed-gear pump				●	Arm, 4 ft. 5.0 in. (1340 mm)	▲	▲			Rear secondary exit kit
●	●	●	●	Hydraulic pilot controls for boom, arm, bucket, and swing	●	●	●	●	Articulation hose shield					Electrical
●	●	●	●	Wet-disc swing brake	●				Backfill blade, 4 ft. 4 in. (1350 mm)	●	●	●	●	12-volt accessory outlet
				Undercarriage				●	Backfill blade, 5 ft. 1 in. (1550 mm)	●	●	●	●	Alternator, 35 amp
●	●	●	●	Planetary final drive					Backfill blade, 5 ft. 7 in. (1700 mm)	●	●	●	●	Low-maintenance battery
●	●	●	●	Propel motor shield				●	Backfill blade, 6 ft. 7 in. (2000 mm)	●	●	●	●	Blade-type multi-fused circuits
●				Rubber track, 9 in. (230 mm)	●	●			Boom, 6 ft. 10.5 in. (2100 mm)	●	●	●	●	Positive-terminal battery covers
	●	●		Rubber track, 12 in. (300 mm)			●		Boom, 8 ft. 0.25 in. (2450 mm)	●	●	●	●	Lights
		●	●	Rubber track, 16 in. (400 mm)				●	Boom, 9 ft. 2 in. (2890 mm)	●	●	●	●	Work lights: Halogen / One mounted on frame / One mounted on boom
●	●	●	●	Two-speed axial-piston propel motors	●	●	●	●	Mechanical quick-coupler					
▲				Steel track, 9 in. (230 mm) with triple semi-grousers										
▲	▲			Steel track, 12 in. (300 mm) with triple semi-grousers										
▲				Steel track, 16 in. (400 mm) with triple semi-grousers										

Control Owning and Operating Costs

Customer Personal Service (CPS) is part of John Deere's proactive, fix-before-fail strategy on machine maintenance that will help control costs, increase profits, and reduce stress. Included in this comprehensive lineup of ongoing programs and services are:

Fluid analysis program – tells you what's going on inside *all* of your machine's major components so you'll know if there's a problem *before* you see a decline in performance. Fluid analysis is included in most extended coverage and preventive-maintenance agreements.

Component life-cycle data – gives you vital information on the projected life span of components and lets you make informed decisions on machine maintenance by telling you approximately how many hours of use you can expect from an engine, transmission, or hydraulic pump. This information can be used to preempt catastrophic downtime by servicing major components at about 80 percent of their life cycle.

Preventive Maintenance (PM) agreements – give you a fixed cost for maintaining a machine for a given period of time. They also help you avoid downtime by ensuring that critical maintenance

work gets done right and on schedule. On-site preventive maintenance service performed where and when you need it helps protect you from the expense of catastrophic failures and lets you avoid waste-disposal hassles.

Extended coverage – gives you a fixed cost for machine repairs for a given period of time so you can effectively manage costs. Whether you work in a severe-service setting or just want to spread the risk of doing business, this is a great way to custom-fit coverage for your operation. And an extended coverage contract also travels well because it's backed by John Deere and is honored by *all* Deere construction dealers.

Customer Support Advisors (CSAs) – Deere believes the CSA program lends a *personal* quality to Customer Personal Service (CPS). Certified CSAs have the knowledge and skills for helping make important decisions on machine maintenance and repair. Their mission is to help you implement a plan that's right for *your* business and take the burden of machine maintenance off your shoulders.



JOHN DEERE

Net engine power is with standard equipment including air cleaner, exhaust system, alternator, and cooling fan, at standard conditions per SAE J1349 and DIN 6270B, using No. 2-D fuel at 35 API gravity. No derating is required up to 10,000-ft. (3050 m) altitude. Gross power is without cooling fan.

Specifications and design subject to change without notice. Wherever applicable, specifications are in accordance with SAE standards. Except where otherwise noted, these specifications are based on a canopy unit with full fuel tank and 175-lb. (79 kg) operator; 17ZTS unit with 17.7-in. (450 mm), 1.5-cu. ft. (0.04 m³) bucket, 9-in. (230 mm) rubber track, and 672-lb. (305 mm) counterweight; 27ZTS unit with 20-in. (508 mm), 2.8-cu. ft. (0.08 m³) bucket, 12-in. (300 mm) rubber track, and 672-lb. (305 kg) counterweight; 35ZTS unit with 24-in. (610 mm), 4.0-cu. ft. (0.11 m³) bucket, 12-in. (300 mm) rubber track, and 1,225-lb. (556 kg) counterweight; and 50ZTS unit with 24-in. (610 mm), 5.7-cu. ft. (0.16 m³) bucket, 16-in. (400 mm) rubber track, and 1,323-lb. (600 kg) counterweight. Lift capacities shown are for base machine above with mechanical quick-coupler, less bucket.

