



JOHN DEERE

# 2156G SWING MACHINE





2156G SWING MACHINE

## TAME YOUR TOUGHEST TIMBER.

When you work in the woods, you know that tackling timber is hardly routine. You have to be at the top of your game all day, every day. And that includes your equipment. So we asked for ideas on how to make our purpose-built swing machines even better from loggers just like you. After thousands of hours devoted to redesigning components, testing structures, and implementing major cab updates that set comfort and safety standards, our 2156G Swing Machine is more than ready to help you face whatever comes your way in the forest.

### **Designed for durability**

More dependable electrical architecture simplifies wiring harnesses and the number of connectors, fuses, and relays by approximately 25 percent compared to previous models. Undercarriage X-frame and upper-frame structure have been improved to deliver longer life. Large, high-capacity coolers

with optimized airflow help reduce hydraulic operating temperatures, maximizing component durability.

### **Reliable rollers**

Larger-diameter lower rollers with polished shafts and improved seals compared to earlier models extend wear life while reducing downtime and maintenance costs.

### **It hardly seems like work**

With an additional three inches of legroom over earlier models, the cab is isolation mounted to reduce noise and vibration, cushion the ride in rough terrain, and substantially minimize fatigue. Ergonomically correct short-throw pilot levers provide smooth, precise fingertip control with less movement or effort.

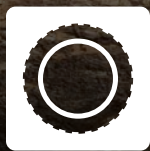

## **LARGE-DIAMETER LOWER ROLLERS** **EXTEND WEAR LIFE**

### **Forward thinking**

Two cab options significantly enhance operator comfort. Side-entry cab is 25-percent larger than the previous model. Standard rear-entry cab features windows in the floor and injection-molded polycarbonate windows, for superb visibility to the tracks and work area. Cab-forward design boosts visibility to the right.

### **Get in on the ground game**

Optional on the 2156G, longer track frames put more track on the ground, for increased stability — and up to 14-percent more lifting capacity — than the model it replaces.

### **No half measures here**

“Half-lever” hydraulic-control system reduces fuel consumption by three to five percent compared to the 2156D Swing Machine, depending on the application. Ground-level service access and conveniently located filters, fluid-fill locations, and grease points help ease daily checks and preventive maintenance.

2156G SWING MACHINE

# PUT TECHNOLOGY TO WORK IN THE WOODS AND AT THE OFFICE.

Coordinate your operation and your team's productivity from wherever your work takes you with John Deere Precision Forestry and our core technology solutions.

## FEATURES

### Core intelligence

Your John Deere Forestry machine arrives from the factory equipped with a powerful set of technologies and capabilities already built in. Each plays an important role in managing the health and performance of your overall equipment fleet:

- **JDLink™** connectivity lets you track your equipment, see which machines are working, and know if they're being utilized properly and at maximum productivity and efficiency.
- Enabled through JDLink, **John Deere Connected Support™** leverages a suite of dealer and factory tools designed to deliver increased uptime and productivity, and lower daily operating costs.
- **Remote Diagnostics and Programming Capability** within John Deere Connected Support helps your dealer warn you of any issue with your machine — often before you know of the problem yourself — and initiate solutions without charging you for a technician's visit to your jobsite.
- Our advanced dual approach to **Machine Health** combines the expertise of the technology specialists at our dealerships with the data specialists at our central Machine Health Monitoring Center (MHMC). As part of John Deere Connected Support, information from thousands of connected machines flows through the MHMC, enabling our specialists to identify trends and develop new and improved preventative-maintenance and repair protocols.



## JOHN DEERE PRECISION FORESTRY

TOOLS ENABLE PRODUCTION  
PLANNING & TRACKING

### Precision Forestry

Take the guesswork out of planning, implementing, and monitoring your logging operation. The tools of our production-planning and -tracking system expand on the core technology features that come standard in every John Deere Forestry machine to unleash a powerful new array of possibilities:

- **TimberMatic™ Maps** is an innovative onboard software solution that helps you reimagine your jobsites. Real-time production views, optimized routes, and shared wireless connections between machines make it easier than ever before to take your forestry operation to the next level.
- **TimberManager™** is a web-based solution for PCs, tablets, and mobile phones that allows you to follow jobsite progress. Combined with TimberMatic Maps, this software provides complete visibility of your operation — from land harvested to specific machines — so you can streamline communication, analyze tasks, and increase productivity:
  - **Remote Monitoring** keeps tabs on the health and performance of your fleet from wherever you are.
  - **Precise Progress Tracking** lets you set goals for your team to meet throughout the day.
  - **Live Production View** displays progress including tree count, area harvested, and estimated tonnage.
  - **Simplified Mapping** of machine data and GPS-based location tracking shows precise stem and log counts.
  - **Real-Time Updates** let you adjust course or eliminate tasks if needed to maintain steady workflow.
  - **Fleet Optimization** goes beyond machine management to help improve the efficiency of your business.

# 2156G SWING MACHINE SPECIFICATIONS

Engine	2156G Valve-in-Head (VIH) Log Loader / Live-Heel Log Loader			
Manufacturer and Model	John Deere PowerTech™ PVS 6.8 L	John Deere PowerTech™ Plus 6.8 L	John Deere PowerTech Plus 6.8 L	
Non-Road Emission Standards	EPA Final Tier 4 (FT4)/EU Stage IV	EPA Tier 3/EU Stage IIIA	EPA Tier 2/EU Stage II	
Net Rated Power (ISO 9249)	122 kW (164 hp) at 2,000 rpm	122 kW (164 hp) at 2,000 rpm	122 kW (164 hp) at 2,000 rpm	
Cylinders	6	6	6	
Engine Displacement	6.8 L (415 cu. in.)	6.8 L (415 cu. in.)	6.8 L (415 cu. in.)	
Off-Level Capacity	70% (35 deg.)	70% (35 deg.)	70% (35 deg.)	
Aspiration	Turbocharged, air-to-air charge-air cooler	Turbocharged, air-to-air charge-air cooler	Turbocharged, air-to-air charge-air cooler	
Oil Filter, Remote Mounted	Full-flow spin-on filter	Full-flow spin-on filter	Full-flow spin-on filter	
Cooling	Cool-on-demand hydraulic-driven, suction-type fan with remote-mounted drive and standard reversing fan			
Powertrain	2-speed propel with automatic shift			
Undercarriage	2.62 m (8 ft. 7 in.) Standard Duty (SD)/Heavy Duty (HD)	Extreme Duty (XD)	2.79 m (9 ft. 2 in.) HD	XDLC
Maximum Travel Speed				
Low	3.2 km/h (2.0 mph)	2.6 km/h (1.6 mph)	3.2 km/h (2.0 mph)	2.6 km/h (1.6 mph)
High	4.8 km/h (3.0 mph)	3.6 km/h (2.2 mph)	4.8 km/h (3.0 mph)	3.6 km/h (2.2 mph)
Drawbar Pull	22 634 kgf (49,900 lbf)	30 350 kgf (66,910 lbf)	22 634 kgf (49,900 lbf)	30 350 kgf (66,910 lbf)
Hydraulics	Open center, pilot operated			
<b>Main Pumps</b>	2 variable-displacement pumps			
Maximum Rated Flow x 2	236 L/m (62.3 gpm)			
<b>System Operating Pressure</b>				
Implement Circuits	34 300 kPa (4,975 psi)			
Power Boost	38 000 kPa (5,511 psi)			
Controls	Pilot levers; short-stroke, low-effort hydraulic pilot with shutoff lever			
Electrical	EPA FT4/EU Stage IV		EPA Tier 3/EU Stage IIIA / EPA Tier 2/EU Stage II	
System Voltage	24 volt		24 volt	
Alternator Rating	150 amp		130 amp	
Lights (standard)				
Work	14 LEDs		14 LEDs	
Service				
With Side-Entry Cab	5 LEDs (compartments)		5 LEDs (compartments)	
With Rear-Entry Cab	6 LEDs (compartments and riser)		6 LEDs (compartments and riser)	
Access	1 LED (right rear cab)		1 LED (right rear cab)	
Undercarriage				
Carrier Rollers (per side)	2			
Track Rollers (per side)				
HD/XD	8			
XDLC	9			
Shoes, Double Grousers (per side)				
HD	46			
XD	45			
Undercarriage Pitch				
HD	203 mm (8.0 in.)			
XD	216 mm (8.5 in.)			
Ground Pressure	2156G VIH Log Loader		2156G Live-Heel Log Loader	
Undercarriage	2.62 m (8 ft. 7 in.) HD	XD	2.79 m (9 ft. 2 in.) HD	XDLC
700-mm (28 in.) Double-Grouser Shoes	67.6 kPa (9.80 psi)*	62.9 kPa (9.12 psi)	58.2 kPa (8.44 psi)	59.0 kPa (8.56 psi)
			68.2 kPa (9.89 psi)*	63.5 kPa (9.21 psi)
				58.7 kPa (8.51 psi)
				59.5 kPa (8.63 psi)

\*With 600-mm (24 in.) double-grouser shoes.

Swing Mechanism		2156G VIH Log Loader / Live-Heel Log Loader
Swing Speed		12.6 rpm
Swing Torque		74 376 Nm (54,857 lb.-ft.)

Operator's Station	
Operator Height From Ground (eye level)	
Side-Entry Forestry Cab	2998 mm (9 ft. 11 in.)
Rear-Entry Log Loader Cab	4345 mm (14 ft. 4 in.)
Standard rearview camera	

Serviceability	
Refill Capacities	
Fuel Tank	800.0 L (211 gal.)
Cooling System	30.5 L (8.1 gal.)
Diesel Exhaust Fluid (DEF) Tank (FT4 only)	42.4 L (11.2 gal.)
Engine Crankcase (including filter)	20.0 L (20.6 qt.)
Hydraulic Tank Oil	136.0 L (36.0 gal.)

Operating Weights	2156G VIH Log Loader	2156G Live-Heel Log Loader
With full fuel tank, 79-kg (175 lb.) operator, 60-in riser, rear-entry forestry cab, 5673-kg (12,503 lb.) counterweight, 700-mm (28 in.) double-grouser shoes, and 2.79-m (9 ft. 2 in.) undercarriage; no attachment included		

	EPA Tier 3/EU Stage IIIA / EPA FT4/EU Stage IV	EPA Tier 2/EU Stage II	EPA Tier 3/EU Stage IIIA / EPA FT4/EU Stage IV	EPA Tier 2/EU Stage II
SAE Operating Weight	31 222 kg (68,833 lb.)	30 995 kg (68,333 lb.)	31 509 kg (69,465 lb.)	31 282 kg (68,965 lb.)

Optional Components (add weight)			
Side-Entry Cab		-671 kg (-1,480 lb.)	-671 kg (-1,480 lb.)
Rear-Entry Cab – Cab Forward		68 kg (150 lb.)	68 kg (150 lb.)
Undercarriage			
2.62-m (8 ft. 7 in.) HD		-106 kg (-233 lb.)	-106 kg (-233 lb.)
2.62-m (8 ft. 7 in.) XD		3134 kg (6,910 lb.)	3134 kg (6,910 lb.)
2.79-m (9 ft. 2 in.) XDLC		3924 kg (8,651 lb.)	3924 kg (8,651 lb.)

Operating Dimensions		2156G VIH Log Loader	2156G Live-Heel Log Loader
With standard equipment, 700-mm (28 in.) shoes, 5673-kg (12,503 lb.) counterweight, full fuel tank, and 79-kg (175 lb.) operator			
		4.32-m (14 ft. 2 in.) VIH Log Loader Arm	4.04-m (13 ft. 3 in.) Live-Heel Log Loader Arm
<b>A</b> Maximum Reach		9.93 m (32 ft. 7 in.)	10.97 m (36 ft. 0 in.)
<b>A'</b> Maximum Reach at Ground Level		9.70 m (31 ft. 10 in.)	10.77 m (35 ft. 4 in.)
<b>B</b> Maximum Working Depth		3.30 m (10 ft. 10 in.)	4.32 m (14 ft. 2 in.)
<b>C</b> Maximum Working Height		11.61 m (38 ft. 1 in.)	12.65 m (41 ft. 6 in.)
<b>D</b> Maximum Log-Level Height		9.19 m (30 ft. 2 in.)*	8.23 m (27 ft. 0 in.) <sup>†</sup>
<b>D'</b> Maximum Log-Level Height		N/A	9.25 m (30 ft. 4 in.) <sup>‡</sup>
<b>E</b> Minimum Swing Radius		4.57 m (15 ft. 0 in.)	4.24 m (13 ft. 11 in.)
<b>F</b> Tail Swing Radius		3.25 m (10 ft. 8 in.)	3.25 m (10 ft. 8 in.)

\*Attachment dependent.

<sup>†</sup>Log resting on heel rack rear plate, attachment dependent.

<sup>‡</sup>Log resting on heel rack front plate, attachment dependent.

2156G VIH Log Loader

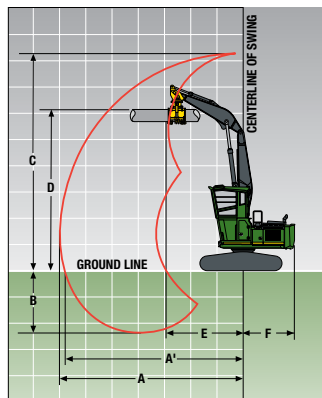

2156G Live-Heel Log Loader

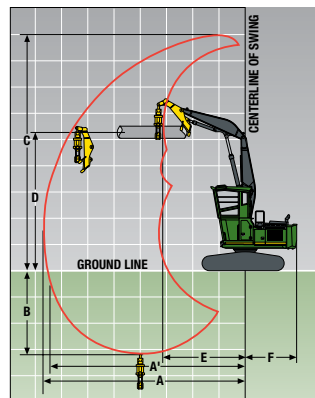

# 2156G SWING MACHINE SPECIFICATIONS (continued)

Machine Dimensions	2156G VIH Log Loader				2156G Live-Heel Log Loader			
	2.62 m (8 ft. 7 in.)		2.79 m (9 ft. 2 in.)		2.62 m (8 ft. 7 in.)		2.79 m (9 ft. 2 in.)	
Undercarriage	SD/HD	XD	HD	XDLC	SD/HD	XD	HD	XDLC
<b>A</b> Machine Transport Height								
Side-Entry Cab	3.78 m (12 ft. 5 in.)	3.78 m (12 ft. 5 in.)	3.78 m (12 ft. 5 in.)	3.78 m (12 ft. 5 in.)	3.78 m (12 ft. 5 in.)	3.78 m (12 ft. 5 in.)	3.78 m (12 ft. 5 in.)	3.78 m (12 ft. 5 in.)
Rear-Entry Cab	3.63 m (11 ft. 11 in.)	3.63 m (11 ft. 11 in.)	3.63 m (11 ft. 11 in.)	3.63 m (11 ft. 11 in.)	3.63 m (11 ft. 11 in.)	3.63 m (11 ft. 11 in.)	3.63 m (11 ft. 11 in.)	3.63 m (11 ft. 11 in.)
<b>B</b> Overall Length	13.80 m (45 ft. 3 in.)	13.80 m (45 ft. 3 in.)	13.80 m (45 ft. 3 in.)	13.80 m (45 ft. 3 in.)	13.61 m (44 ft. 8 in.)	13.61 m (44 ft. 8 in.)	13.61 m (44 ft. 8 in.)	13.61 m (44 ft. 8 in.)
<b>C</b> Rear-End Length / Swing Radius	3.20 m (10 ft. 6 in.)	3.20 m (10 ft. 6 in.)	3.20 m (10 ft. 6 in.)	3.20 m (10 ft. 6 in.)	3.20 m (10 ft. 6 in.)	3.20 m (10 ft. 6 in.)	3.20 m (10 ft. 6 in.)	3.20 m (10 ft. 6 in.)
<b>D</b> Distance Between Idler / Sprocket Centerline	3.66 m (12 ft. 0 in.)	3.73 m (12 ft. 3 in.)	3.66 m (12 ft. 0 in.)	4.06 m (13 ft. 4 in.)	3.66 m (12 ft. 0 in.)	3.73 m (12 ft. 3 in.)	3.66 m (12 ft. 0 in.)	4.06 m (13 ft. 4 in.)
<b>E</b> Undercarriage Length	4.45 m (14 ft. 7 in.)	4.70 m (15 ft. 5 in.)	4.45 m (14 ft. 7 in.)	5.03 m (16 ft. 6 in.)	4.45 m (14 ft. 7 in.)	4.70 m (15 ft. 5 in.)	4.45 m (14 ft. 7 in.)	5.03 m (16 ft. 6 in.)
<b>F</b> Counterweight Clearance	1.37 m (4 ft. 6 in.)	1.37 m (4 ft. 6 in.)	1.37 m (4 ft. 6 in.)	1.37 m (4 ft. 6 in.)	1.37 m (4 ft. 6 in.)	1.37 m (4 ft. 6 in.)	1.37 m (4 ft. 6 in.)	1.37 m (4 ft. 6 in.)
<b>G</b> Upperstructure Width	3.23 m (10 ft. 7 in.)	3.23 m (10 ft. 7 in.)	3.23 m (10 ft. 7 in.)	3.23 m (10 ft. 7 in.)	3.23 m (10 ft. 7 in.)	3.23 m (10 ft. 7 in.)	3.23 m (10 ft. 7 in.)	3.23 m (10 ft. 7 in.)
<b>H</b> Cab Operating Height								
Side-Entry Cab	3.78 m (12 ft. 5 in.)	3.78 m (12 ft. 5 in.)	3.78 m (12 ft. 5 in.)	3.78 m (12 ft. 5 in.)	3.78 m (12 ft. 5 in.)	3.78 m (12 ft. 5 in.)	3.78 m (12 ft. 5 in.)	3.78 m (12 ft. 5 in.)
Rear-Entry Cab	5.13 m (16 ft. 10 in.)	5.13 m (16 ft. 10 in.)	5.13 m (16 ft. 10 in.)	5.13 m (16 ft. 10 in.)	5.13 m (16 ft. 10 in.)	5.13 m (16 ft. 10 in.)	5.13 m (16 ft. 10 in.)	5.13 m (16 ft. 10 in.)
<b>H<sup>1</sup></b> Tilted Cab Height (rear-entry cab)	3.63 m (11 ft. 11 in.)	3.63 m (11 ft. 11 in.)	3.63 m (11 ft. 11 in.)	3.63 m (11 ft. 11 in.)	3.63 m (11 ft. 11 in.)	3.63 m (11 ft. 11 in.)	3.63 m (11 ft. 11 in.)	3.63 m (11 ft. 11 in.)
<b>I</b> Track Shoe Width	600 mm (24 in.)	700 mm (28 in.)	700 mm (28 in.)	700 mm (28 in.)	600 mm (24 in.)	700 mm (28 in.)	700 mm (28 in.)	700 mm (28 in.)
<b>J</b> Center of Sprocket to Center of Sprocket	2.62 m (8 ft. 7 in.)	2.62 m (8 ft. 7 in.)	2.79 m (9 ft. 2 in.)	2.79 m (9 ft. 2 in.)	2.62 m (8 ft. 7 in.)	2.62 m (8 ft. 7 in.)	2.79 m (9 ft. 2 in.)	2.79 m (9 ft. 2 in.)
<b>K</b> Ground Clearance	0.71 m (28 in.)	0.71 m (28 in.)	0.76 m (30 in.)	0.76 m (30 in.)	0.71 m (28 in.)	0.71 m (28 in.)	0.76 m (30 in.)	0.76 m (30 in.)
<b>L</b> Undercarriage Width	3.28 m (10 ft. 9 in.) w/ 600-mm (24 in.) shoes	3.33 m (11 in.) w/ 700-mm (28 in.) shoes	3.51 m (11 ft. 6 in.) w/ 700-mm (28 in.) shoes	3.53 m (11 ft. 7 in.) w/ 700-mm (28 in.) shoes	3.28 m (10 ft. 9 in.) w/ 600-mm (24 in.) shoes	3.33 m (11 in.) w/ 700-mm (28 in.) shoes	3.51 m (11 ft. 6 in.) w/ 700-mm (28 in.) shoes	3.53 m (11 ft. 7 in.) w/ 700-mm (28 in.) shoes

2156G VIH Log Loader

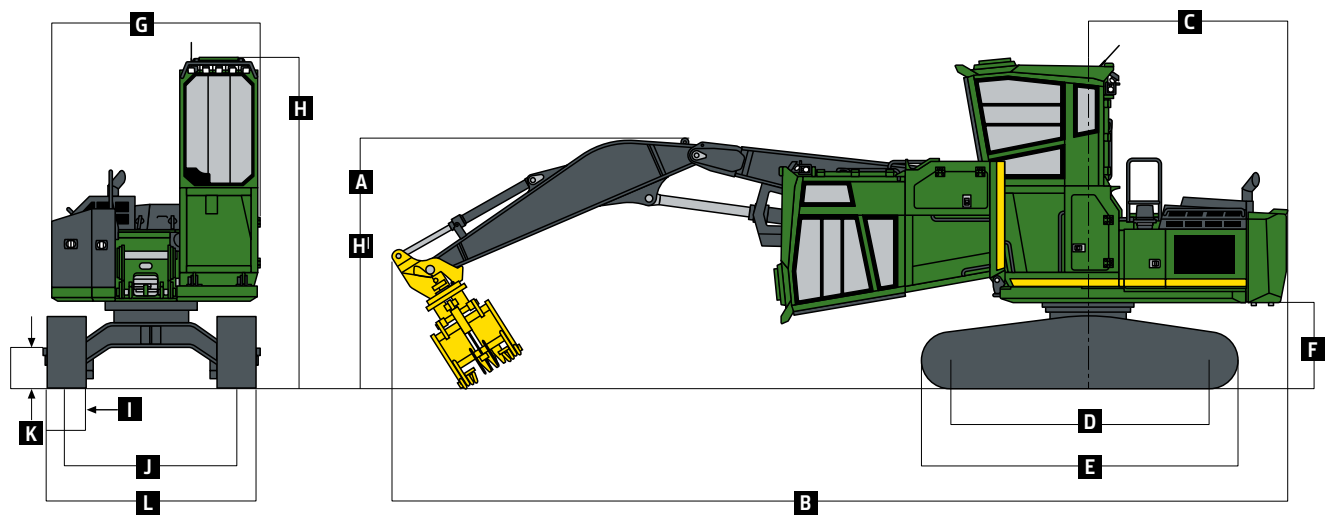

While general information, pictures, and descriptions are provided, some illustrations and text may include product options and accessories NOT AVAILABLE in all regions, and in some countries products and accessories may require modifications or additions to ensure compliance with the local regulations of those countries.



2156G Live-Heel Log Loader – Side-Entry Cab

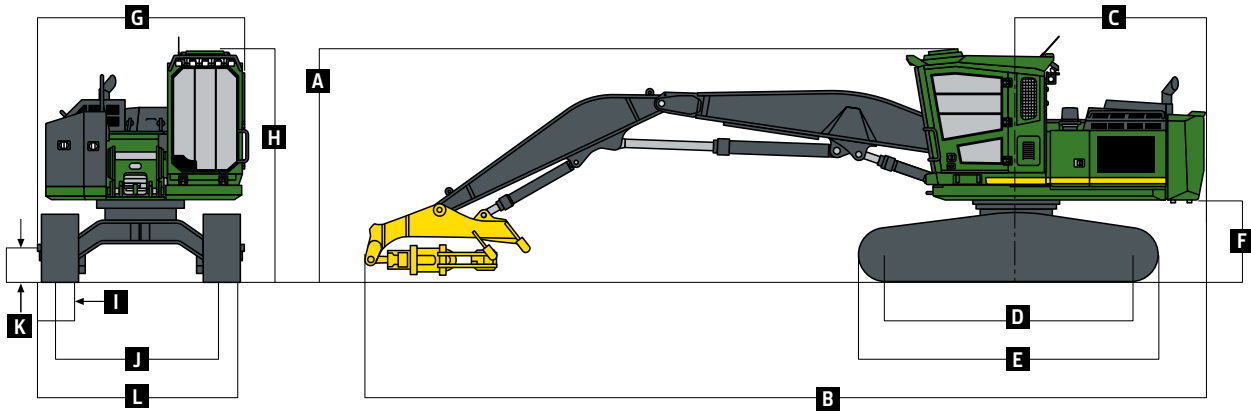

2156G Live-Heel Log Loader – Rear-Entry Cab

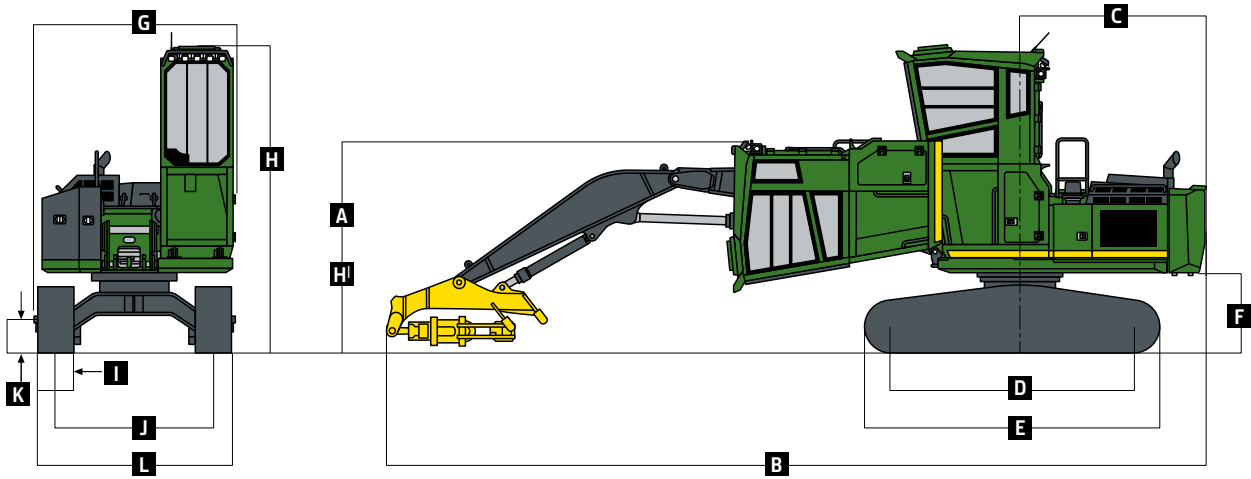

# 2156G SWING MACHINE SPECIFICATIONS (continued)

Attachment weight is not included when calculating the lift capacities. Boldface type indicates hydraulic-limited capacities with power boost; lightface type indicates stability-limited capacities, in kg (lb.). Figures do not exceed 87 percent of hydraulic capacities or 75 percent of weight needed to tip machine.

Lift Capacity — 2156G VIH Log Loader with 2.62-m (8 ft. 7 in.) XD undercarriage, 700-mm (28 in.) shoes, and extra-heavy counterweight; bare pin										
Load Point Height	3.1 m (10 ft.)		4.6 m (15 ft.)		6.1 m (20 ft.)		7.6 m (25 ft.)		9.1 m (30 ft.)	
	Over Front	Over Side	Over Front	Over Side	Over Front	Over Side	Over Front	Over Side	Over Front	Over Side
10.7 m (35 ft.)			<b>11 670</b> (25,720)	<b>11 670</b> (25,720)						
9.1 m (30 ft.)			<b>10 220</b> (22,530)	<b>10 220</b> (22,530)	<b>9070</b> (19,990)	<b>9070</b> (19,990)				
7.6 m (25 ft.)					<b>8740</b> (19,260)	<b>8740</b> (19,260)	<b>7890</b> (17,380)	6780 (14,940)		
6.1 m (20 ft.)			<b>10 340</b> (22,780)	<b>10 340</b> (22,780)	<b>8930</b> (19,690)	<b>8930</b> (19,690)	<b>7870</b> (17,350)	6780 (14,950)		
4.6 m (15 ft.)			<b>11 580</b> (25,520)	<b>11 580</b> (25,520)	<b>9500</b> (20,930)	9360 (20,620)	<b>8070</b> (17,790)	6670 (14,700)	<b>6900</b> (15,200)	5040 (11,110)
3.1 m (10 ft.)					<b>10 200</b> (22,480)	9000 (19,840)	<b>8320</b> (18,330)	6500 (14,320)	6840 (15,080)	4970 (10,950)
1.5 m (5 ft.)					<b>10 660</b> (23,500)	8630 (19,030)	<b>8390</b> (18,490)	6310 (13,910)	<b>6650</b> (14,650)	4890 (10,770)
Ground Line			<b>14 290</b> (31,490)	12 550 (27,650)	<b>10 480</b> (23,100)	8350 (18,400)	<b>8050</b> (17,730)	6160 (13,590)	<b>6010</b> (13,240)	4830 (10,640)
-1.5 m (-5 ft.)	<b>17 050</b> (37,570)	<b>17 050</b> (37,570)	<b>12 520</b> (27,600)	12 330 (27,170)	<b>9370</b> (20,650)	8210 (18,080)	<b>7000</b> (15,430)	6090 (13,420)	<b>4440</b> (9,770)	<b>4440</b> (9,770)
-3.1 m (-10 ft.)			<b>9280</b> (20,440)	<b>9280</b> (20,440)	<b>7080</b> (15,600)	<b>7080</b> (15,600)				
Lift Capacity — 2156G VIH Log Loader with 2.79-m (9 ft. 2 in.) HD undercarriage, 700-mm (28 in.) shoes, and extra-heavy counterweight; bare pin										
10.7 m (35 ft.)			<b>11 700</b> (25,800)	<b>11 700</b> (25,800)						
9.1 m (30 ft.)			<b>10 240</b> (22,570)	<b>10 240</b> (22,570)	<b>9110</b> (20,070)	<b>9110</b> (20,070)				
7.6 m (25 ft.)					<b>8770</b> (19,340)	<b>8770</b> (19,340)	<b>7930</b> (17,480)	6570 (14,490)		
6.1 m (20 ft.)			<b>10 360</b> (22,830)	<b>10 360</b> (22,830)	<b>8970</b> (19,770)	<b>8970</b> (19,770)	<b>7920</b> (17,450)	6580 (14,500)		
4.6 m (15 ft.)			<b>11 620</b> (25,600)	<b>11 620</b> (25,600)	<b>9540</b> (21,030)	9110 (20,080)	<b>8120</b> (17,900)	6470 (14,260)	6170 (13,600)	4870 (10,740)
3.1 m (10 ft.)					<b>10 260</b> (22,600)	8760 (19,320)	<b>8030</b> (17,690)	6300 (13,890)	6100 (13,450)	4810 (10,590)
1.5 m (5 ft.)					<b>10 730</b> (23,650)	8400 (18,520)	<b>7830</b> (17,270)	6120 (13,490)	6020 (13,260)	4730 (10,410)
Ground Line			<b>14 380</b> (31,700)	12 300 (27,100)	<b>10 560</b> (23,270)	8120 (17,900)	<b>7680</b> (16,930)	5970 (13,170)	5960 (13,130)	4670 (10,280)
-1.5 m (-5 ft.)	<b>17 200</b> (37,900)	<b>17 200</b> (37,900)	<b>12 630</b> (27,830)	12 080 (26,630)	<b>9450</b> (20,830)	7980 (17,590)	<b>7070</b> (15,580)	5900 (13,010)	<b>4490</b> (9,910)	<b>4490</b> (9,910)
-3.1 m (-10 ft.)			<b>9380</b> (20,670)	<b>9380</b> (20,670)	<b>7160</b> (15,780)	<b>7160</b> (15,780)				

While general information, pictures, and descriptions are provided, some illustrations and text may include product options and accessories NOT AVAILABLE in all regions, and in some countries products and accessories may require modifications or additions to ensure compliance with the local regulations of those countries.

Attachment weight is not included when calculating the lift capacities. Boldface type indicates hydraulic-limited capacities with power boost; lightface type indicates stability-limited capacities, in kg (lb.). Figures do not exceed 87 percent of hydraulic capacities or 75 percent of weight needed to tip machine.

**Lift Capacity — 2156G Live-Heel Log Loader with 2.62-m (8 ft. 7 in.) XD undercarriage, 700-mm (28 in.) shoes, and extra-heavy counterweight; bare pin**

Load Point Height	3.1 m (10 ft.)		4.6 m (15 ft.)		6.1 m (20 ft.)		7.6 m (25 ft.)		9.1 m (30 ft.)		10.7 m (35 ft.)	
	Over Front	Over Side	Over Front	Over Side	Over Front	Over Side	Over Front	Over Side	Over Front	Over Side	Over Front	Over Side
12.2 m (40 ft.)	<b>15 750</b> <b>(34,720)</b>	<b>15 750</b> <b>(34,720)</b>										
10.7 m (35 ft.)			<b>9800</b> <b>(21,610)</b>	<b>9800</b> <b>(21,610)</b>	<b>8760</b> <b>(19,300)</b>	8620 (18,990)						
9.1 m (30 ft.)					<b>7830</b> <b>(17,260)</b>	<b>7830</b> <b>(17,260)</b>	<b>7150</b> <b>(15,760)</b>	6190 (13,640)				
7.6 m (25 ft.)					<b>7670</b> <b>(16,910)</b>	<b>7670</b> <b>(16,910)</b>	<b>6910</b> <b>(15,230)</b>	6450 (14,210)	<b>6260</b> <b>(13,810)</b>	4790 (10,550)		
6.1 m (20 ft.)					<b>7940</b> <b>(17,500)</b>	<b>7940</b> <b>(17,500)</b>	<b>7040</b> <b>(15,520)</b>	6460 (14,230)	<b>6190</b> <b>(13,640)</b>	4820 (10,630)		
4.6 m (15 ft.)			<b>9670</b> <b>(21,310)</b>	<b>9670</b> <b>(21,310)</b>	<b>8640</b> <b>(19,040)</b>	<b>8640</b> <b>(19,040)</b>	<b>7350</b> <b>(16,200)</b>	6370 (14,030)	<b>6270</b> <b>(13,810)</b>	4660 (10,280)	5100 (11,240)	3590 (7,920)
3.1 m (10 ft.)			<b>11 470</b> <b>(25,270)</b>	<b>11 470</b> <b>(25,270)</b>	<b>9430</b> <b>(20,780)</b>	8880 (19,570)	<b>7700</b> <b>(16,970)</b>	6210 (13,680)	<b>6360</b> <b>(14,010)</b>	4640 (10,220)	5090 (11,220)	3580 (7,900)
1.5 m (5 ft.)			<b>13 200</b> <b>(29,100)</b>	13 040 (28,750)	<b>10 100</b> <b>(22,260)</b>	8470 (18,670)	<b>7910</b> <b>(17,440)</b>	6020 (13,260)	<b>6350</b> <b>(14,000)</b>	4560 (10,040)	<b>4860</b> <b>(10,720)</b>	3540 (7,800)
Ground Line			<b>13 960</b> <b>(30,770)</b>	12 340 (27,200)	<b>10 210</b> <b>(22,510)</b>	8130 (17,910)	<b>7830</b> <b>(17,250)</b>	5850 (12,900)	<b>6090</b> <b>(13,420)</b>	4440 (9,780)	<b>4170</b> <b>(9,190)</b>	3510 (7,730)
-1.5 m (-5 ft.)	<b>6350</b> <b>(14,000)</b>	<b>6350</b> <b>(14,000)</b>	<b>13 240</b> <b>(29,190)</b>	11 950 (26,340)	<b>9650</b> <b>(21,260)</b>	7900 (17,420)	<b>7530</b> <b>(16,600)</b>	5720 (12,600)	<b>5340</b> <b>(11,760)</b>	4370 (9,630)		
-3.1 m (-10 ft.)	<b>8780</b> <b>(19,360)</b>	<b>8780</b> <b>(19,360)</b>	<b>10 940</b> <b>(24,120)</b>	<b>10 940</b> <b>(24,120)</b>	<b>8220</b> <b>(18,120)</b>	7850 (17,310)	<b>6580</b> <b>(14,500)</b>	5690 (12,530)	<b>3650</b> <b>(8,050)</b>	<b>3650</b> <b>(8,050)</b>		

**Lift Capacity — 2156G Live-Heel Log Loader with 2.79-m (9 ft. 2 in.) HD undercarriage, 700-mm (28 in.) shoes, and extra-heavy counterweight; bare pin**

12.2 m (40 ft.)	<b>15 750</b> <b>(34,720)</b>	<b>15 750</b> <b>(34,720)</b>										
10.7 m (35 ft.)			<b>9800</b> <b>(21,610)</b>	<b>9800</b> <b>(21,610)</b>	<b>8760</b> <b>(19,300)</b>	8310 (18,310)						
9.1 m (30 ft.)					<b>7830</b> <b>(17,260)</b>	<b>7830</b> <b>(17,260)</b>	<b>7150</b> <b>(15,760)</b>	5930 (13,080)				
7.6 m (25 ft.)					<b>7670</b> <b>(16,910)</b>	<b>7670</b> <b>(16,910)</b>	<b>6910</b> <b>(15,230)</b>	6190 (13,640)	5880 (12,970)	4570 (10,070)		
6.1 m (20 ft.)					<b>7940</b> <b>(17,500)</b>	<b>7940</b> <b>(17,500)</b>	<b>7040</b> <b>(15,520)</b>	6200 (13,670)	5920 (13,050)	4610 (10,150)		
4.6 m (15 ft.)			<b>9670</b> <b>(21,310)</b>	<b>9670</b> <b>(21,310)</b>	<b>8640</b> <b>(19,040)</b>	<b>8640</b> <b>(19,040)</b>	<b>7350</b> <b>(16,200)</b>	6110 (13,470)	5750 (12,680)	4440 (9,790)	4450 (9,800)	3400 (7,500)
3.1 m (10 ft.)			<b>11 470</b> <b>(25,270)</b>	<b>11 470</b> <b>(25,270)</b>	<b>9430</b> <b>(20,780)</b>	8580 (18,900)	7700 (16,960)	5950 (13,110)	5730 (12,620)	4410 (9,730)	4430 (9,770)	3390 (7,470)
1.5 m (5 ft.)			<b>13 200</b> <b>(29,100)</b>	12 700 (27,980)	<b>10 100</b> <b>(22,260)</b>	8160 (17,990)	7490 (16,510)	5760 (12,690)	5640 (12,430)	4330 (9,550)	4390 (9,670)	3340 (7,370)
Ground Line			<b>13 960</b> <b>(30,770)</b>	11 970 (26,390)	<b>10 210</b> <b>(22,510)</b>	7810 (17,220)	7310 (16,120)	5590 (12,320)	5520 (12,160)	4220 (9,290)	<b>4170</b> <b>(9,190)</b>	3310 (7,300)
-1.5 m (-5 ft.)	<b>6350</b> <b>(14,000)</b>	<b>6350</b> <b>(14,000)</b>	<b>13 240</b> <b>(29,190)</b>	11 570 (25,510)	<b>9650</b> <b>(21,260)</b>	7590 (16,720)	7170 (15,810)	5460 (12,030)	<b>5340</b> <b>(11,760)</b>	4150 (9,140)		
-3.1 m (-10 ft.)	<b>9750</b> <b>(21,490)</b>	<b>9750</b> <b>(21,490)</b>	<b>10 940</b> <b>(24,120)</b>	11 410 (25,150)	<b>8220</b> <b>(18,120)</b>	7540 (16,620)	<b>6580</b> <b>(14,500)</b>	5420 (11,950)	<b>3650</b> <b>(8,050)</b>	<b>3650</b> <b>(8,050)</b>		



MSW2156GC (23-01)

Contact us to learn more.

[JohnDeere.com/SwingMachines](https://JohnDeere.com/SwingMachines)  
[JohnDeere.ca/SwingMachines](https://JohnDeere.ca/SwingMachines)



**JOHN DEERE**