

ENGINE

John Deere engineered and manufactured. Replaceable wet type cylinder liners provide superior heat dissipation, longer life. High strength alloy head has replaceable valve seat inserts. The forged steel, 5-main bearing crankshaft is statically and dynamically balanced for smooth operation. Cast aluminum pistons provide good heat transfer and pistons are sprayed with cooling oil for longer life.

Engine: John Deere 4045T Turbocharged
 Rated power at 2,200 rpm.....95 SAE net hp (71 kW)
100 SAE gross hp (75 kW)
 Cylinders4
 Displacement276 cu. in. (4.524 L)
 Fuel consumption, typical1.6 to 2.6 gal./hr. (6.0 to 9.8 L/h)
 Torque rise25 percent
 Maximum net torque268 lb.-ft. (363 Nm)
 LubricationPressure system w/full flow filter and cooler
 Air cleanerDual stage dry type with safety element and precleaner
 Electrical system12 volt with 95-amp alternator
 Sucker-type cooling fan

TRANSMISSION

John Deere designed and built 4-speed helical gear, synchronized in all four gears, collar shift transmission with hydraulic reverser. Uses single stage, dual phase, 11-inch (280 mm) torque converter with 2.23:1 stall ratio.

TRAVEL SPEEDS

Gear	Forward		Reverse	
	mph	(km/h)	mph	(km/h)
1	3.4	5.5	3.9	6.3
2	5.9	9.5	6.8	10.9
3	12.6	20.3	14.5	23.3
4	19.7	32.7	22.6	36.4

With 21L-24 rear tires

FINAL DRIVES

Heavy-duty, inboard mounted planetary type. Evenly distribute axle shock loads over three gears that run in a cooling oil bath.

BRAKES

Hydraulic wet disk service brakes are mounted inboard and are pressure cooled and lubricated. They're self-adjusting and self-equalizing. Individual pedals can be applied together or separately. **Parking/emergency brake** is an independent system that is spring-applied, hydraulically released, and controlled by an electric switch on the control console. Automatically neutralizes reverser when parking brake is applied. A mechanical V-groove band applies pressure on differential ring gear. All brakes conform to SAE J1473.

CAPACITIES

	U.S.
Fuel tank	34 gal. (129 L)
Engine coolant	17 qt. (16 L)
Engine oil including filter	9 qt. (8.5 L)
Torque converter and reverser system	14 qt. (13 L)
Hydraulic system	21 gal. (79 L)
Transaxle with MFWD	5.5 gal. (21 L)

STEERING

Hydrostatic power steering gives superior control at all speeds. Excellent steering torque allows easy maneuvering with heavy loads. Power steering conforms to SAE J1151 and emergency steering SAE J53.

Non-powered axle
 Curb turning radius with brakes11 ft. 8 in. (3.55 m)
 without brakes13 ft. 3 in. (4.04 m)
 Bucket clearance circle with brakes31 ft. 8 in. (9.64 m)
 without brakes34 ft. 9 in. (10.60 m)
 Steering wheel turns, stop to stop2.2 to 2.9
 Mechanical-front-wheel drive
 Curb turning radius with brakes11 ft. 5 in. (3.49 m)
 without brakes13 ft. 6 in. (4.11 m)
 Bucket clearance circle with brakes29 ft. 7 in. (9.02 m)
 without brakes33 ft. 8 in. (10.26 m)
 Steering wheel turns, stop to stop2.5
 Axle oscillation, stop to stop, both axles22 degrees

Axle ratings:	Static	Dynamic	SAE J43
Front	56,000 lb. (25 300 kg)	56,000 lb. (25 300 kg)	21,100 lb. (9500 kg)
Rear	51,000 lb. (23 100 kg)	68,000 lb. (30 800 kg)	16,800 lb. (7600 kg)

HYDRAULICS

Systemclosed center
 Pressure, main relief2,755 psi (19 000 kPa)
 Pumpradial pistons
 Flow at 2200 rpm35 gpm (133 L/min.)
 Filter, return oil10 micron, spin-on, replaceable element

CYLINDERS

	Bore		Stroke		Rod	
	in. (mm)	in. (mm)	in. (mm)	in. (mm)	in. (mm)	in. (mm)
Loader boom (2)	3.54	90	29.84	758	1.77	45
Loader bucket (1)	3.94	100	28.19	718	1.97	50
Backhoe boom (1)	5.00	127	42.72	1085	2.50	64
Backhoe crowd (1)	4.53	115	34.57	878	2.48	63
Backhoe bucket (1)	3.54	90	31.00	788	1.97	50
Backhoe swing (2)	3.94	100	9.49	241	1.97	50
Backhoe extendable dipper (1)	2.50	64	48.00	1220	1.25	32
Backhoe stabilizer (2)	3.94	100	19.96	507	1.97	50
Steering (1) non-powered axle	1.97	50	9.50	241	0.98	25
Steering (1) MFWD	2.36	60	7.90	202	0.98	25

TIRES

Rear	Front
19.5L-24, 10 PR R4	11L-16, 12 PR F3
19.5L-24, 12 PR R4	11L-16, 12 PR F3
21L-24, 10 PR R4	14.5/75-16.1, 10 PR F3
With mechanical-front-wheel drive	
21L-24, 10 PR R4	12.00-16.5, 8 PR, Sure Grip
18.4-28L, 12 PR R4	14.00-17.5, 10 PR, Sure Grip
19.5L-24, 12 PR R4	12.00-16.5, 8 PR, Sure Grip

OPERATING WEIGHTS

SAE
 510D16,000 lb. (7260 kg)
 cab adds500 lb. (227 kg)
 mechanical-front-wheel drive adds190 lb. (86 kg)
 5 ft. (1.5 m) extendable dipperstick
 with required counterweight adds1,182 lb. (536 kg)
 optional front counterweights add1,200 lb. (453 kg)
 backhoe bucket coupler adds200 lb. (91 kg)
 See backhoe and loader performance data for bucket weights

Specifications and design subject to change without notice. Wherever applicable, specifications are in accordance with SAE standards. Except where otherwise noted, these specifications are based on a unit with 19.5L-24, 10 PR R4 rear tires, 11L-16, 12 PR F3 front tires, 1.42 cu. yd. (1.09 m³) loader bucket, 24 in. x 8.8 cu. ft. (610 mm x 0.25 m³) heavy-duty backhoe bucket.

DIMENSIONS

(a-f) See Loader Performance

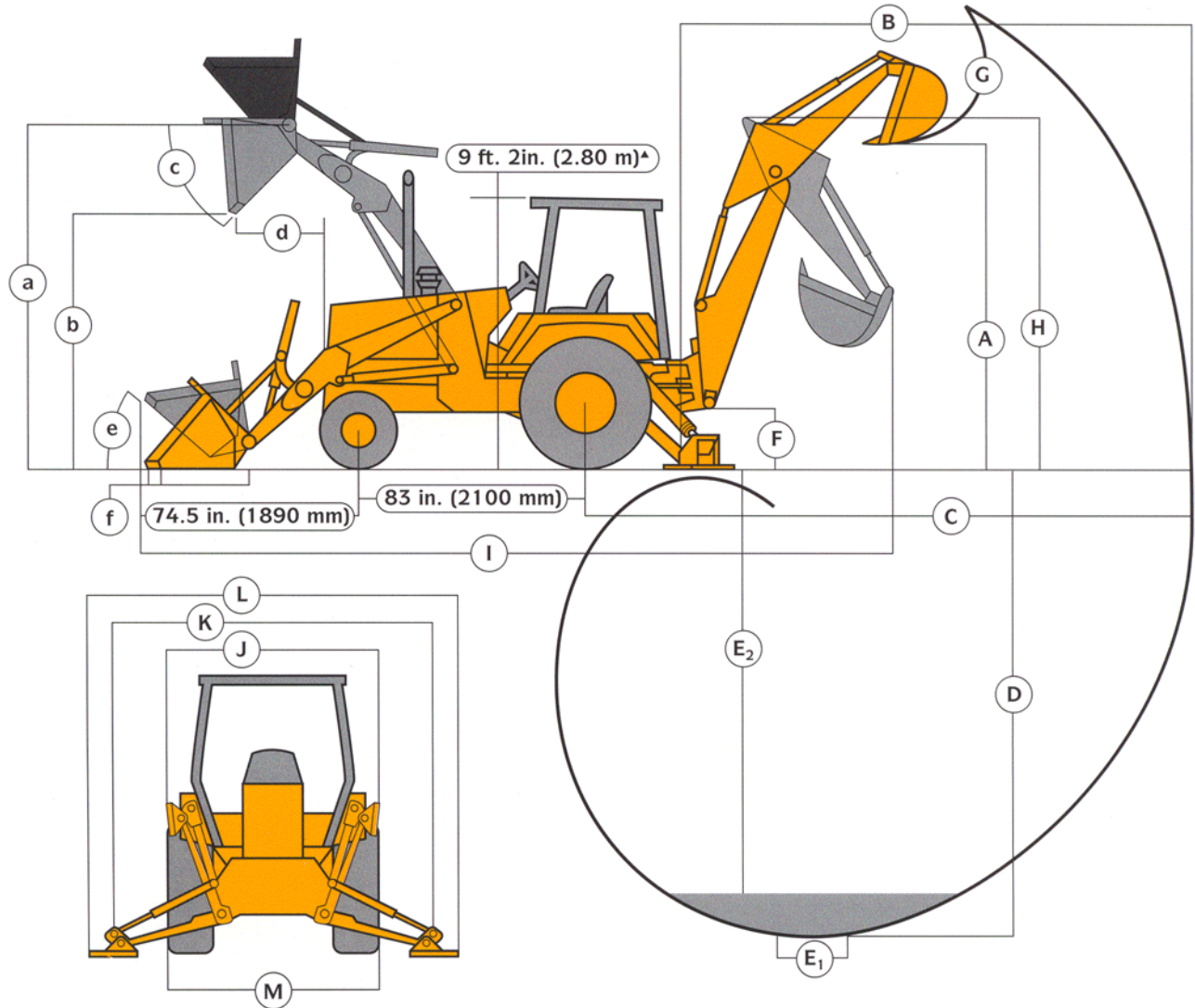

▲ ROPS and cab

Key:

A. Loading height, truck loading position	12 ft. 7 in. (3.84 m)
B. Reach from center of swing mast.....	19 ft. 11 in. (6.07 m)
C. Reach from center of rear axle	23 ft. 8 in. (7.21 m)
D. Maximum digging depth	16 ft. 8 in. (5.07 m)
E. Digging depth (SAE):	
(1) 2-ft. (610 mm) flat bottom.....	16 ft. 6 in. (5.03 m)
(2) 8-ft. (2440 mm) flat bottom.....	15 ft. 7 in. (4.74 m)
F. Ground clearance, minimum.....	13 in. (330 mm)
G. Bucket rotation	160 or 180 degrees
H. Transport height.....	12 ft. 4 in. (4.51 m)
I. Overall length, transport.....	23 ft. 4 in. (7.11 m)
J. Stabilizer width – transport.....	7 ft. 8 in. (2.34 m)
K. Stabilizer spread – operating.....	9 ft. 10 in. (3.00 m)
L. Stabilizer overall width – operating.....	11 ft. 4 in. (3.45 m)
M. Width over tires.....	86 in. (2.62 m)

Backhoe Standard Dipperstick*

Extendable Dipperstick

Retracted	Extended
12 ft. 1 in. (3.69 m)	15 ft. (4.58 m)
19 ft. 3 in. (5.87 m)	23 ft. 11 in. (7.29 m)
23 ft. (7.01 m)	27 ft. 8 in. (8.43 m)
15 ft. 11 in. (4.86 m)	20 ft. 10 in. (6.34 m)
15 ft. 11 in. (4.86 m)	20 ft. 8 in. (6.30 m)
14 ft. 10 in. (4.51 m)	20 ft. (6.09 m)
13 in. (330 mm)	13 in. (330 mm)
160 or 180 degrees	160 or 180 degrees
13 ft. 5 in. (4.90 m)	13 ft. 5 in. (4.90 m)
23 ft. (7.01 m)	23 ft. (7.01 m)
7 ft. 8 in. (2.34 m)	7 ft. 8 in. (2.34 m)
9 ft. 10 in. (3.00 m)	9 ft. 10 in. (3.00 m)
11 ft. 4 in. (3.45 m)	11 ft. 4 in. (3.45 m)
86 in. (2.62 m)	86 in. (2.62 m)

BACKHOE PERFORMANCE

Digging force, bucket cylinder (power dig position).....	11,100 lb. (49.5 kN)	11,230 lb. (49.9 kN)	11,230 lb. (49.9 kN)
Digging force, crowd cylinder	7,600 lb. (33.8 kN)	8,390 lb. (37.0 kN)	5,430 lb. (24.2 kN)
Swing arc	180 degrees	180 degrees	180 degrees
Operator control.....	Two levers	Right foot treadle	Right foot treadle
Bucket positions	8 or 17 deg. rollback	8 or 18 deg. rollback	12 or 21 deg. rollback
Stabilizer angle rearward	14.5 degrees	14.5 degrees	14.5 degrees
Lifting capacity, maximum	6,780 lb. (3074 kg)	7,232 lb. (3279 kg)	3,616 lb. (1639 kg)
Leveling angle.....	13 degrees	13 degrees	13 degrees

*Backhoe specifications are with 24-in. x 8.8 cu. ft. (610 mm x 0.25 m³) bucket.

LIFT CAPACITY Backhoe with standard dipperstick.
Based on SAE J31.

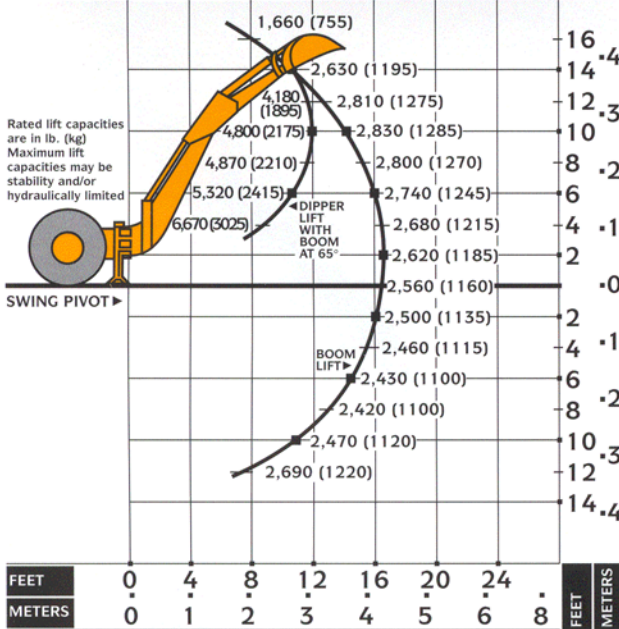

LIFT CAPACITY Backhoe with 5 ft. (1.52 m)
dipperstick, retracted. Based on SAE J31.

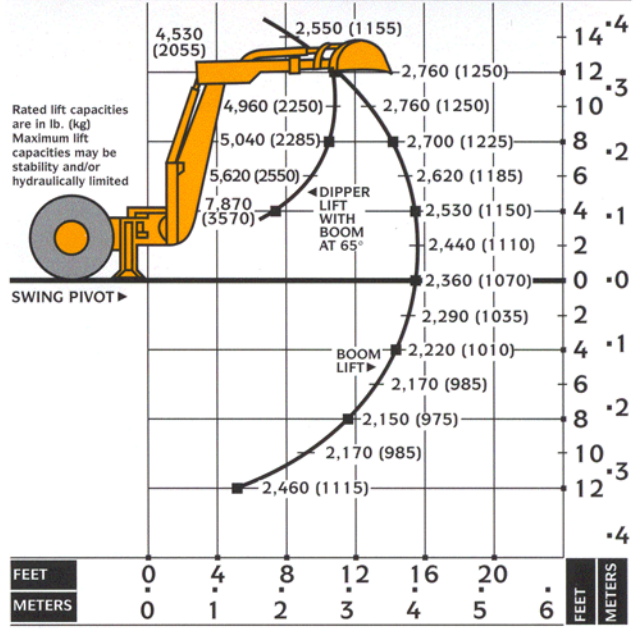

LIFT CAPACITY Backhoe with 5 ft. (1.52 m)
dipperstick, extended. Based on SAE J31.

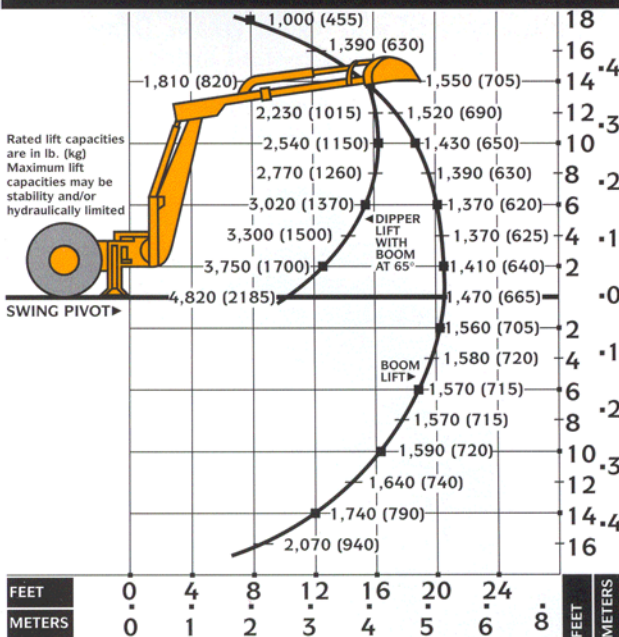

BACKHOE BUCKETS

	Width		Capacity		Weight	
	in.	(mm)	cu. ft.	(m ³)	lb.	(kg)
Standard-duty	12	(305)	2.5	(0.07)	244	(111)
	18	(457)	5.1	(0.14)	322	(146)
	24	(610)	7.5	(0.21)	370	(168)
	30	(762)	10.0	(0.28)	410	(186)
	36	(914)	9.9	(0.28)	430	(195)
Heavy-duty	12	(305)	2.5	(0.07)	258	(117)
	18	(457)	5.1	(0.14)	334	(151)
	24	(610)	7.5	(0.21)	396	(180)
	24	(610)	8.8	(0.25)	476	(216)
	30	(762)	10.0	(0.28)	444	(201)
Extra heavy-duty	36	(914)	10.0	(0.28)	470	(214)
	18	(457)	5.1	(0.14)	362	(164)
	24	(610)	7.5	(0.21)	424	(192)
	30	(762)	10.0	(0.28)	474	(215)
	Ditch cleaning	36	(914)	10.0	(0.28)	370
36		(914)	14.5	(0.41)	500	(235)

LOADER BUCKETS

Loader:	Width		Heaped Capacity		Weight	
	in.	(mm)	cu. yd.	(m ³)	lb.	(kg)
Heavy-duty long lip*	92	(2340)	1.42	(1.09)	965	(438)
Heavy-duty long lip*	92	(2340)	1.62	(1.24)	1,160	(527)
General purpose	89	(2270)	1.25	(0.96)	750	(340)
			Multipurpose	1.25	(0.96)	1,560

*With auxiliary cutting edge and skid shoes standard.
NOTE: All buckets pre-drilled for auxiliary cutting edge.

LOADER PERFORMANCE

w/1.42 cu. yd. (1.09 m³) Heavy-Duty Long Lip Bucket

Operator control single lever

Breakout force 10,410 lb. (46.3 kN)

Lifting capacity, full height 7,300 lb. (3310 kg)

a) Height to bucket hinge pin, max. 11 ft. 1 in. (3.38 m)

b) Dump clearance, bucket at 45 degrees 8 ft. 9 in. (2.67 m)

c) Bucket dump angle, max. 45 degrees

d) Reach at full height, bucket at 45 degrees 29.1 in. (739 mm)

e) Rollback angle at ground level 40 degrees

f) Digging depth below ground, bucket level 4 in. (100 mm)

Raising time to full height 4.4 sec.

Bucket dump time 1.0 sec.

Bucket lowering time (power down) 3.0 sec.

w/1.25 cu. yd. (0.96 m³) General Purpose Long Lip Bucket

Operator control single lever

Breakout force 9,900 lb. (44.0 kN)

Lifting capacity, full height 7,050 lb. (3195 kg)

a) Height to bucket hinge pin, max. 11 ft. 1 in. (3.38 m)

b) Dump clearance, bucket at 45 degrees 8 ft. 5 in. (2.58 m)

c) Bucket dump angle, max. 45 degrees

d) Reach at full height, bucket at 45 degrees 34 in. (868 mm)

e) Rollback angle at ground level 40 degrees

f) Digging depth below ground, bucket level 4 in. (100 mm)

Raising time to full height 4.4 sec.

Bucket dump time 1.0 sec.

Bucket lowering time (power down) 3.0 sec.

w/1.62 cu. yd. (1.24 m³) Heavy-Duty Long Lip Bucket

Operator control single lever

Breakout force 9,900 lb. (44.0 kN)

Lifting capacity, full height 7,050 lb. (3195 kg)

a) Height to bucket hinge pin, max. 11 ft. 1 in. (3.38 m)

b) Dump clearance, bucket at 45 degrees 8 ft. 7 in. (2.63 m)

c) Bucket dump angle, max. 45 degrees

d) Reach at full height, bucket at 45 degrees 31 in. (787 mm)

e) Rollback angle at ground level 40 degrees

f) Digging depth below ground, bucket level 4 in. (100 mm)

Raising time to full height 4.4 sec.

Bucket dump time 1.0 sec.

Bucket lowering time (power down) 3.0 sec.

w/1.25 cu. yd. (0.96 m³) Multi-purpose Bucket

Operator control single lever

Breakout force 9,700 lb. (43.1 kN)

Lifting capacity, full height 7,000 lb. (3170 kg)

a) Height to bucket hinge pin, max. 11 ft. 1 in. (3.38 m)

b) Dump clearance, bucket at 45 degrees 8 ft. 7 in. (2.63 m)

c) Bucket dump angle, max. 45 degrees

d) Reach at full height, bucket at 45 degrees 28.5 in. (724 mm)

e) Rollback angle at ground level 40 degrees

f) Digging depth below ground, bucket level 5 in. (125 mm)

Raising time to full height 4.4 sec.

Bucket dump time 1.0 sec.

Bucket lowering time (power down) 3.0 sec.